

Chapter 6

MCS-85™

MCS-80™

Systems

Support

Components

Peripherals

Static RAMs

ROMs-EPROMs

MOS

600

MOS

600



8041A/8641A/8741A UNIVERSAL PERIPHERAL INTERFACE 8-BIT MICROCOMPUTER

- 8-Bit CPU plus ROM, RAM, I/O, Timer and Clock in a Single Package
- One 8-Bit Status and Two Data Registers for Asynchronous Slave-to-Master Interface
- DMA, Interrupt, or Polled Operation Supported
- 1024 x 8 ROM/EPROM, 64 x 8 RAM, 8-Bit Timer/Counter, 18 Programmable I/O Pins
- Fully Compatible with MCS-48™, MCS-80™, MCS-85™, and MCS-86™ Microprocessor Families
- Interchangeable ROM and EPROM Versions
- 3.6 MHz 8741A-8 Available
- Expandable I/O
- RAM Power-Down Capability
- Over 90 Instructions: 70% Single Byte
- Single 5V Supply

The Intel® 8041A/8741A is a general purpose, programmable interface device designed for use with a variety of 8-bit microprocessor systems. It contains a low cost microcomputer with program memory, data memory, 8-bit CPU, I/O ports, timer/counter, and clock in a single 40-pin package. Interface registers are included to enable the UPI device to function as a peripheral controller in MCS-48™, MCS-80™, MCS-85™, MCS-86™, and other 8-bit systems.

The UPI-41A™ has 1K words of program memory and 64 words of data memory on-chip. To allow full user flexibility the program memory is available as ROM in the 8041A version or as UV-erasable EPROM in the 8741A version. The 8741A and the 8041A are fully pin compatible for easy transition from prototype to production level designs. The 8641A is a one-time programmable (at the factory) 8741A which can be ordered as the first 25 pieces of a new 8041A order. The substitution of 8641A's for 8041A's allows for very fast turnaround for initial code verification and evaluation results.

The device has two 8-bit, TTL compatible I/O ports and two test inputs. Individual port lines can function as either inputs or outputs under software control. I/O can be expanded with the 8243 device which is directly compatible and has 16 I/O lines. An 8-bit programmable timer/counter is included in the UPI device for generating timing sequences or counting external inputs. Additional UPI features include: single 5V supply, low power standby mode (in the 8041A), single-step mode for debug (in the 8741A), and dual working register banks.

Because it's a complete microcomputer, the UPI provides more flexibility for the designer than conventional LSI interface devices. It is designed to be an efficient controller as well as an arithmetic processor. Applications include keyboard scanning, printer control, display multiplexing and similar functions which involve interfacing peripheral devices to microprocessor systems.

PIN CONFIGURATION

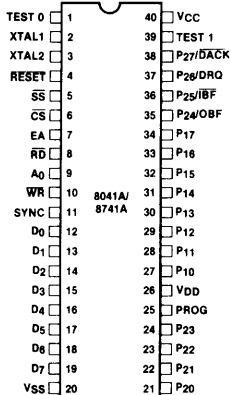

BLOCK DIAGRAM

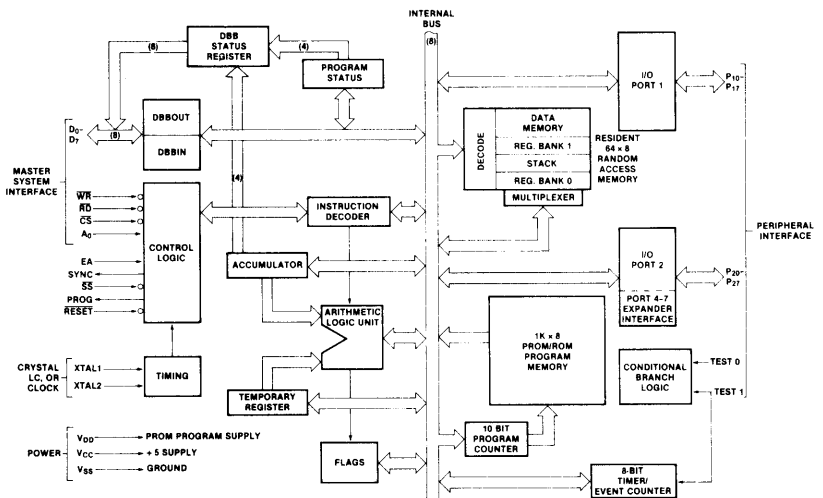



8202 DYNAMIC RAM CONTROLLER

- Provides All Signals Necessary to Control 2104A, 2117, or 2118 Dynamic Memories
- Directly Addresses and Drives Up to 128K Bytes Without External Drivers
- Provides Address Multiplexing and Strobes
- Provides a Refresh Timer and a Refresh Counter
- Refresh Cycles May be Internally or Externally Requested
- Provides Transparent Refresh Capability
- Fully Compatible with Intel® 8080A, 8085A and 8086 Microprocessors
- Decodes 8085A Status for Advanced Read Capability
- Provides System Acknowledge and Transfer Acknowledge Signals
- Internal or External Clock Capability

The 8202 is a Dynamic RAM System Controller designed to provide all signals necessary to use 2104A, 2117, or 2118 Dynamic RAMs in microcomputer systems. The 8202 provides multiplexed addresses and address strobes, as well as refresh/access arbitration. Refresh cycles can be started internally or externally.

PIN CONFIGURATION

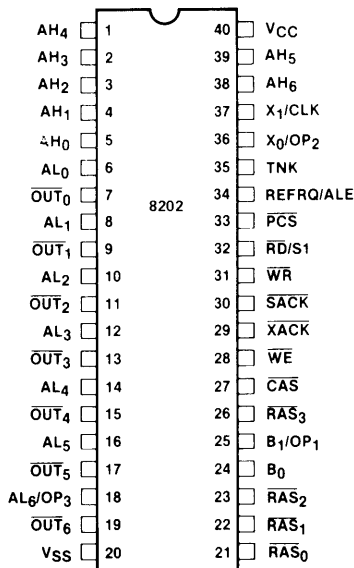

8202 BLOCK DIAGRAM

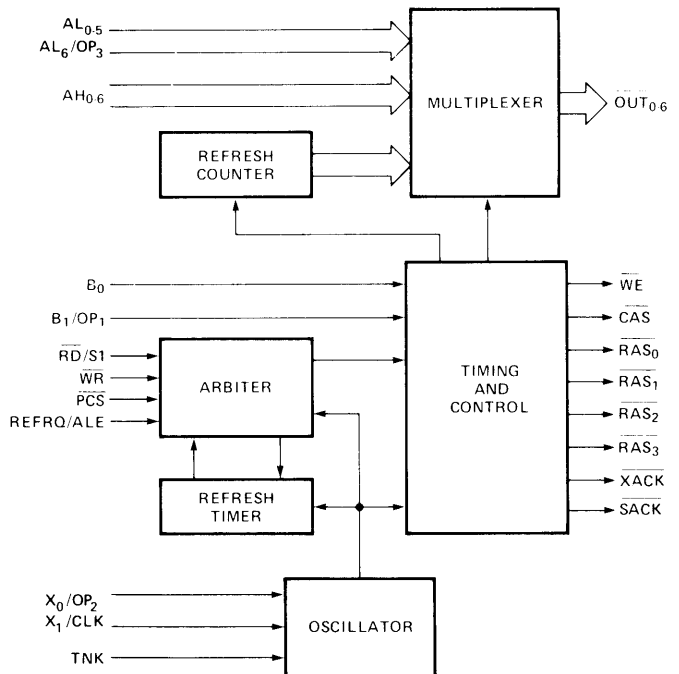



8251A

PROGRAMMABLE COMMUNICATION INTERFACE

PRELIMINARY

Notice: This document contains preliminary information. Intel reserves the right to change parameters without notice.

- Synchronous and Asynchronous Operation
- Synchronous 5-8 Bit Characters; Internal or External Character Synchronization; Automatic Sync Insertion
- Asynchronous 5-8 Bit Characters; Clock Rate—1, 16 or 64 Times Baud Rate; Break Character Generation; 1, 1½, or 2 Stop Bits; False Start Bit Detection; Automatic Break Detect and Handling.
- Synchronous Baud Rate — DC to 64K Baud
- Asynchronous Baud Rate — DC to 19.2K Baud
- Full Duplex, Double Buffered, Transmitter and Receiver
- Error Detection — Parity, Overrun and Framing
- Fully Compatible with 8080/8085 CPU
- 28-Pin DIP Package
- All Inputs and Outputs are TTL Compatible
- Single +5V Supply
- Single TTL Clock

The Intel® 8251A is the enhanced version of the industry standard, Intel® 8251 Universal Synchronous/Asynchronous Receiver/Transmitter (USART), designed for data communications with Intel's new high performance family of microprocessors such as the 8085. The 8251A is used as a peripheral device and is programmed by the CPU to operate using virtually any serial data transmission technique presently in use (including IBM "bi-sync"). The USART accepts data characters from the CPU in parallel format and then converts them into a continuous serial data stream for transmission. Simultaneously, it can receive serial data streams and convert them into parallel data characters for the CPU. The USART will signal the CPU whenever it can accept a new character for transmission or whenever it has received a character for the CPU. The CPU can read the complete status of the USART at any time. These include data transmission errors and control signals such as SYNDT, TxEMPTY. The chip is constructed using N-channel silicon gate technology.

PIN CONFIGURATION

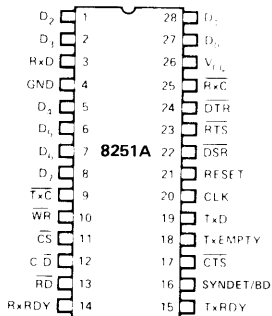

PIN NAMES

D ₇ D ₀	Data Bus (8 bits)
C/D	Control or Data is to be Written or Read
RD	Read Data Command
WR	Write Data or Control Command
CS	Chip Enable
CLK	Clock Pulse (TTL)
RESET	Reset
TxC	Transmitter Clock
TxD	Transmitter Data
RxC	Receiver Clock
RxD	Receiver Data
RxDY	Receiver Ready (has character for 8080)
TxDY	Transmitter Ready (ready for char. from 8080)

DSR	Data Set Ready
DTR	Data Terminal Ready
SYNDT/BD	Sync Detect/ Break Detect
RTS	Request to Send Data
CTS	Clear to Send Data
TxE	Transmitter Empty
V _{CC}	+5 Volt Supply
GND	Ground

BLOCK DIAGRAM

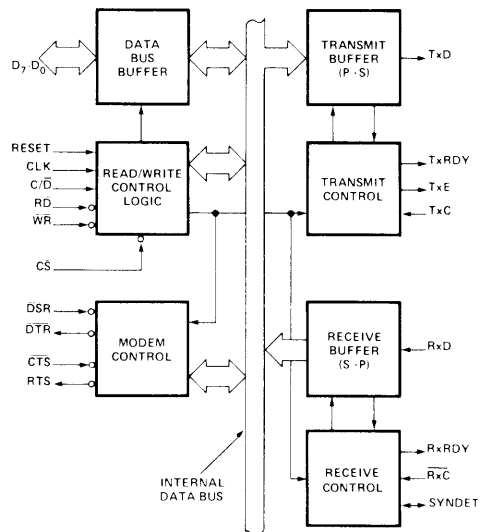



8253/8253-5 PROGRAMMABLE INTERVAL TIMER

- MCS-85™ Compatible 8253-5
 - 3 Independent 16-Bit Counters
 - DC to 2 MHz
 - Programmable Counter Modes
- Count Binary or BCD
 - Single +5V Supply
 - 24-Pin Dual In-Line Package

The Intel® 8253 is a programmable counter/timer chip designed for use as an Intel microcomputer peripheral. It uses nMOS technology with a single +5V supply and is packaged in a 24-pin plastic DIP.

It is organized as 3 independent 16-bit counters, each with a count rate of up to 2 MHz. All modes of operation are software programmable.

PIN CONFIGURATION

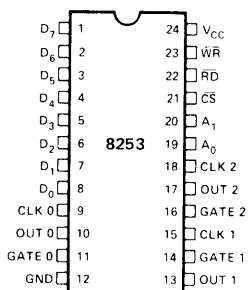

PIN NAMES

D ₇ , D ₀	DATA BUS (8 BIT)
CLK N	COUNTER CLOCK INPUTS
GATE N	COUNTER GATE INPUTS
OUT N	COUNTER OUTPUTS
RD	READ COUNTER
WR	WRITE COMMAND OR DATA
CS	CHIP SELECT
A ₀ , A ₁	COUNTER SELECT
V _{CC}	+5 VOLTS
GND	GROUND

BLOCK DIAGRAM

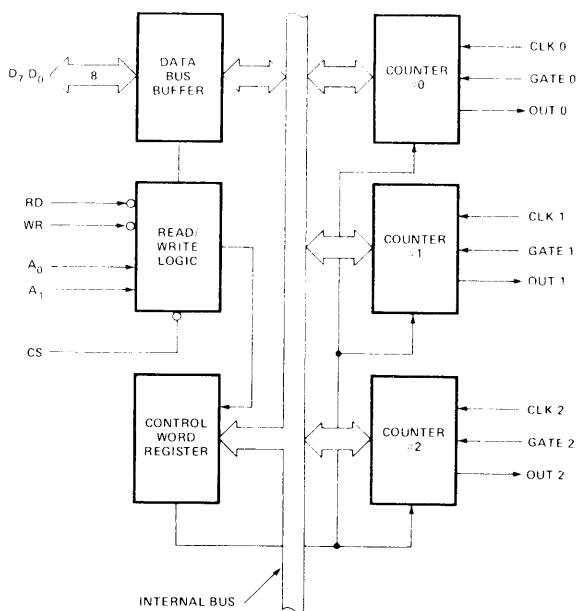



8255A/8255A-5 PROGRAMMABLE PERIPHERAL INTERFACE

- MCS-85™ Compatible 8255A-5
 - 24 Programmable I/O Pins
 - Completely TTL Compatible
 - Fully Compatible with Intel® Micro-processor Families
 - Improved Timing Characteristics
- Direct Bit Set/Reset Capability Easing Control Application Interface
 - 40-Pin Dual In-Line Package
 - Reduces System Package Count
 - Improved DC Driving Capability

The Intel® 8255A is a general purpose programmable I/O device designed for use with Intel® microprocessors. It has 24 I/O pins which may be individually programmed in 2 groups of 12 and used in 3 major modes of operation. In the first mode (MODE 0), each group of 12 I/O pins may be programmed in sets of 4 to be input or output. In MODE 1, the second mode, each group may be programmed to have 8 lines of input or output. Of the remaining 4 pins, 3 are used for handshaking and interrupt control signals. The third mode of operation (MODE 2) is a bidirectional bus mode which uses 8 lines for a bidirectional bus, and 5 lines, borrowing one from the other group, for handshaking.

PIN CONFIGURATION

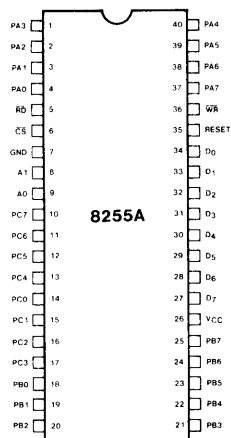

PIN NAMES

D ₇ -D ₀	DATA BUS (BI DIRECTIONAL)
RESET	RESET INPUT
CS	CHIP SELECT
RD	READ INPUT
WR	WRITE INPUT
A ₀ , A ₁	PORT ADDRESS
PA ₇ -PA ₀	PORT A (BIT)
PB ₇ -PB ₀	PORT B (BIT)
PC ₇ -PC ₀	PORT C (BIT)
V _{CC}	+5 VOLTS
GND	0 VOLTS

8255A BLOCK DIAGRAM

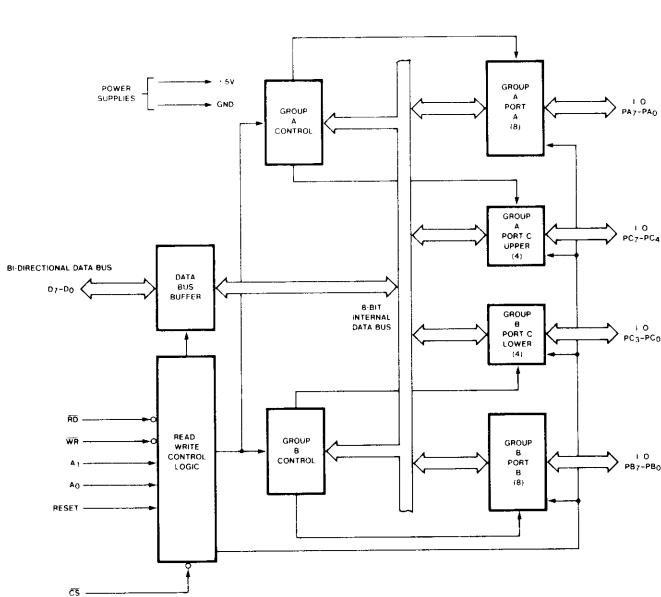

8271 PROGRAMMABLE FLOPPY DISK CONTROLLER

- IBM 3740 Soft Sektored Format Compatible
- Programmable Record Lengths
- Multi-Sector Capability
- Maintain Dual Drives with Minimum Software Overhead Expandable to 4 Drives
- Automatic Read/Write Head Positioning and Verification
- Internal CRC Generation and Checking
- Programmable Step Rate, Settle-Time, Head Load Time, Head Unload Index Count
- Fully MCS-80™ and MCS-85™ Compatible
- Single +5V Supply
- 40-Pin Package

The Intel® 8271 Programmable Floppy Disk Controller (FDC) is an LSI component designed to interface one to 4 floppy disk drives to an 8-bit microcomputer system. Its powerful control functions minimize both hardware and software overhead normally associated with floppy disk controllers.

PIN CONFIGURATION

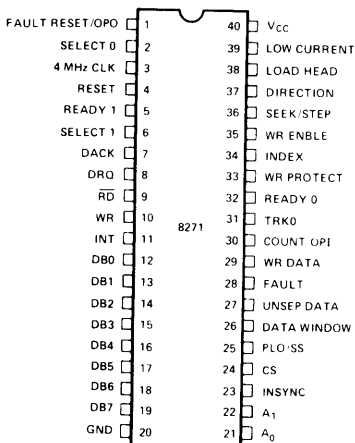

PIN NAMES

DB7 - DB0	DATA BUS (BI DIRECTIONAL): CLOCK INPUT (TTL)	PLO:SS DATA WINDOW UNSEP DATA	PLO:SS SINGLE SHOT DATA WINDOW UNSEPARATED DATA
SELECT 1 0	FAULT RESET/OPO	FAULT	FAULT
RESET	CHIP RESET	WR DATA	WRITE DATA
READY 1 0	DMA ACKNOWLEDGE	COUNT/OPI	COUNT/OPTIONAL INPUT
DACK	DMA REQUEST	TRK0	TRACK 0
DRQ	CPU READ INPUT	WR PROTECT	WRITE PROTECT
RD	CPU WRITE INPUT	INDEX	INDEX
WR	INTERRUPT	WR ENBLE	WRITE ENBLE
INT	REGISTER SELECT	SEEK/STEP	SEEK/STEP
A ₁ 0	READ DATA INSYNC	DIRECTION	DIRECTION
INSYNC	CHIP SELECT	LOAD HEAD	LOAD HEAD
CS		LOW CURRENT	LOW CURRENT

BLOCK DIAGRAM

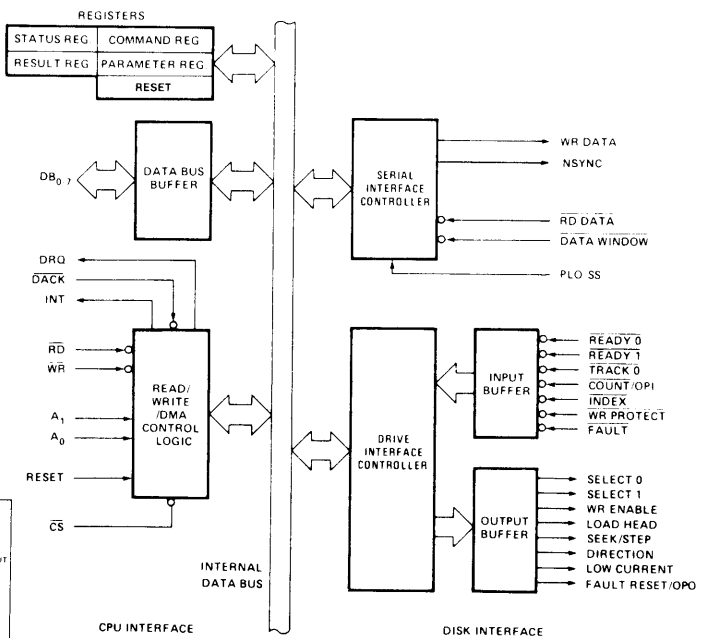

8272 SINGLE/DOUBLE DENSITY FLOPPY DISK CONTROLLER

ADVANCE
INFORMATION
Characteristics are subject to change without notice

- IBM Compatible in Both Single and Double Density Recording Formats
- Programmable Data Record Lengths: 128, 256, 512, or 1024 Bytes/Sector
- Multi-Sector and Multi-Track Transfer Capability
- Drive Up to 4 Floppy Disks
- Data Scan Capability — Will Scan a Single Sector or an Entire Cylinder's Worth of Data Fields, Comparing on a Byte by Byte Basis, Data in the Processor's Memory with Data Read from the Diskette
- Data Transfers in DMA or Non-DMA Mode
- Parallel Seek Operations on Up to Four Drives
- Compatible with Most Microprocessors Including 8080A, 8085A, and 8086
- Single Phase 8 MHz Clock
- Single + 5 Volt Power Supply
- Available in 40-Pin Plastic and Cerdip Dual-in-Line Package

The 8272 is an LSI Floppy Disk Controller (FDC) Chip, which contains the circuitry and control functions for interfacing a processor to 4 Floppy Disk Drives. It is capable of supporting either IBM 3740 single density format (FM), or IBM System 34 Double Density format (MFM) including double sided recording. The 8272 provides control signals which simplify the design of an external phase locked loop, and write precompensation circuitry. The FDC simplifies and handles most of the burdens associated with implementing a Floppy Disk Interface.

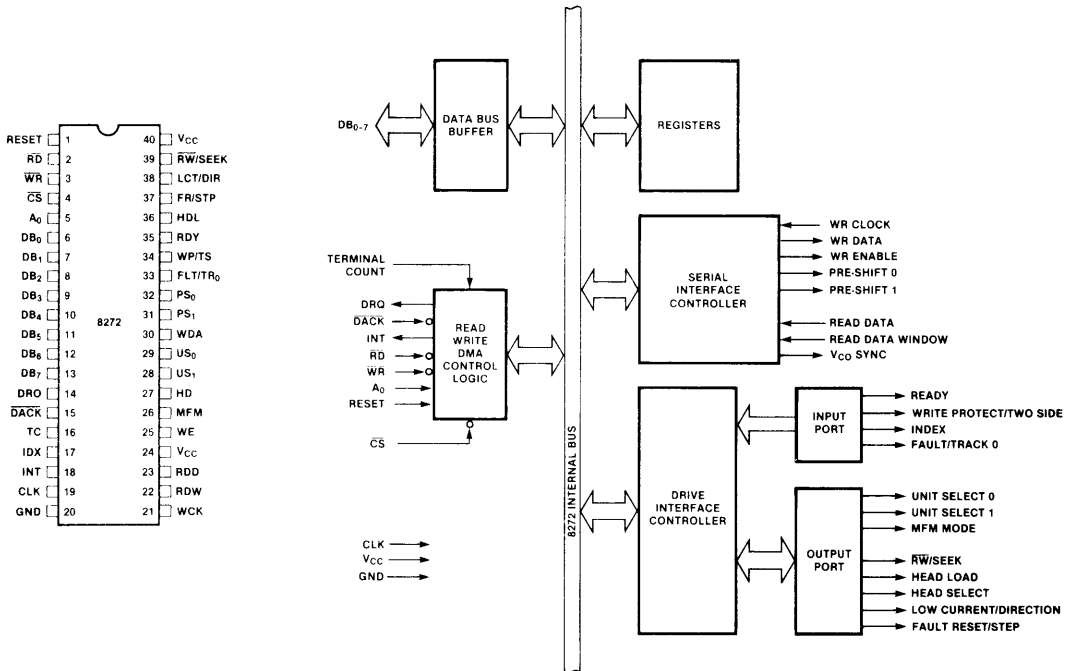



8273 PROGRAMMABLE HDLC/SDLC PROTOCOL CONTROLLER

- HDLC/SDLC Compatible
- Frame Level Commands
- Full Duplex, Half Duplex, or Loop SDLC Operation
- Up to 64K Baud Transfers
- Two User Programmable Modem Control Ports
- Automatic FCS (CRC) Generation and Checking
- Programmable NRZI Encode/Decode
- N-Bit Reception Capability
- Digital Phase Locked Loop Clock Recovery
- Minimum CPU Overhead
- Fully Compatible with 8080/8085 CPUs
- Single +5V Supply
- 40-Pin Package

The Intel® 8273 Programmable HDLC/SDLC Protocol Controller is a dedicated device designed to support the ISO/CITT's HDLC and IBM's SDLC communication line protocols. It is fully compatible with Intel's new high performance microcomputer systems such as the MCS-85™. A frame level command set is achieved by a unique microprogrammed dual processor chip architecture. The processing capability supported by the 8273 relieves the system CPU of the low level real-time tasks normally associated with controllers.

PIN CONFIGURATION

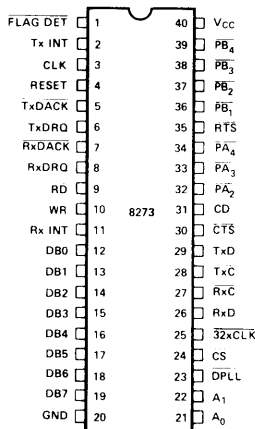

PIN NAMES

DB0-DB7	DATA BUS (8 BITS)	CS	CHIP SELECT
FLAG DET	FLAG DETECT	32xCLK	32 TIMES CLOCK
TxINT	TRANSMITTER INTERRUPT	RxD	RECEIVER DATA
CLK	CLOCK INPUT	RxC	RECEIVER CLOCK
RESET	RESET	TxD	TRANSMITTER DATA
TxDACK	TRANSMITTER DMA ACKNOWLEDGE	TxD	TRANSMITTER DATA
TxDRQ	TRANSMITTER DMA REQUEST	CTS	CLEAR TO SEND
RD	READ INPUT	CD	CARRIER DETECT
WR	WRITE INPUT	GP PA ₂ -PA ₄	GP INPUT PORTS
RxDACK	RECEIVER DMA ACKNOWLEDGE	PB ₁ -PB ₄	GP OUTPUT PORTS
RxDRQ	RECEIVER DMA REQUEST	RTS	REQUEST TO SEND
RxINT	RECEIVER INTERRUPT	Vcc	+5 VOLT SUPPLY
A0-A1	COMMAND REGISTER SELECT ADDRESS	GND	GROUND
DPLL	DIGITAL PHASE LOCKED LOOP		

BLOCK DIAGRAM

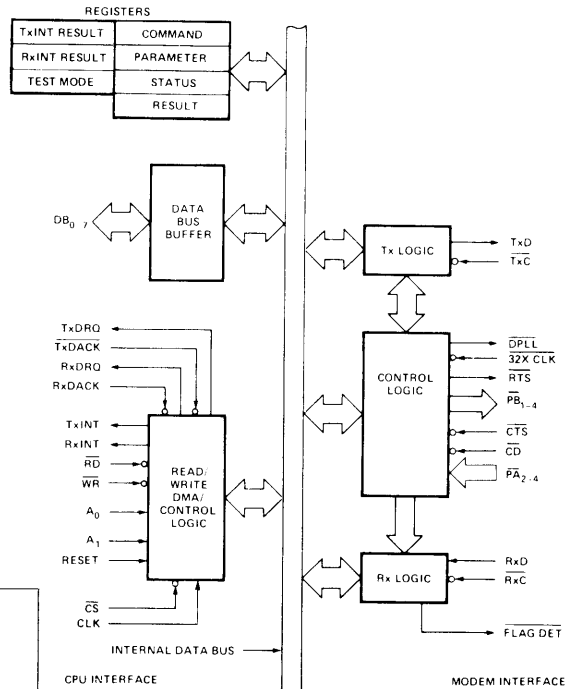



8275 PROGRAMMABLE CRT CONTROLLER

- Programmable Screen and Character Format
- 6 Independent Visual Field Attributes
- 11 Visual Character Attributes (Graphic Capability)
- Cursor Control (4 Types)
- Light Pen Detection and Registers
- Fully MCS-80™ and MCS-85™ Compatible
- Dual Row Buffers
- Programmable DMA Burst Mode
- Single +5V Supply
- 40-Pin Package

The Intel® 8275 Programmable CRT Controller is a single chip device to interface CRT raster scan displays with Intel® microcomputer systems. Its primary function is to refresh the display by buffering the information from main memory and keeping track of the display position of the screen. The flexibility designed into the 8275 will allow simple interface to almost any raster scan CRT display with a minimum of external hardware and software overhead.

PIN CONFIGURATION

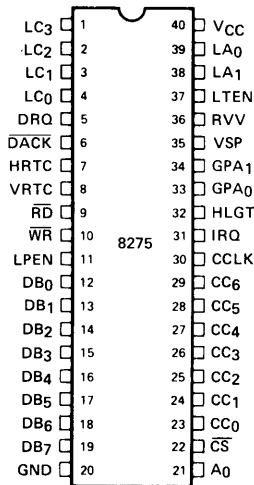

PIN NAMES

DB ₀₋₁	B1-DIRECTIONAL DATA BUS	LC ₀₋₃	LINE COUNTER OUTPUTS
DRQ	DMA REQUEST OUTPUT	LA ₀₋₁	LINE ATTRIBUTE OUTPUTS
DACK	DMA ACKNOWLEDGE INPUT	HRTC	HORIZONTAL RETRACE OUTPUT
IRQ	INTERRUPT REQUEST OUTPUT	VRTC	VERTICAL RETRACE OUTPUT
RD	READ STROBE INPUT	HLGT	HIGHLIGHT OUTPUT
WR	WRITE STROBE INPUT	RVV	REVERSE VIDEO OUTPUT
A ₀	REGISTER ADDRESS INPUT	LTEN	LIGHT ENABLE OUTPUT
CS	CHIP SELECT INPUT	VSP	VIDEO SUPPRESS OUTPUT
CCLK	CHARACTER CLOCK INPUT	GPA ₀₋₁	GENERAL PURPOSE ATTRIBUTE OUTPUTS
CC ₀₋₆	CHARACTER CODE OUTPUTS	LPEN	LIGHT PEN INPUT

BLOCK DIAGRAM

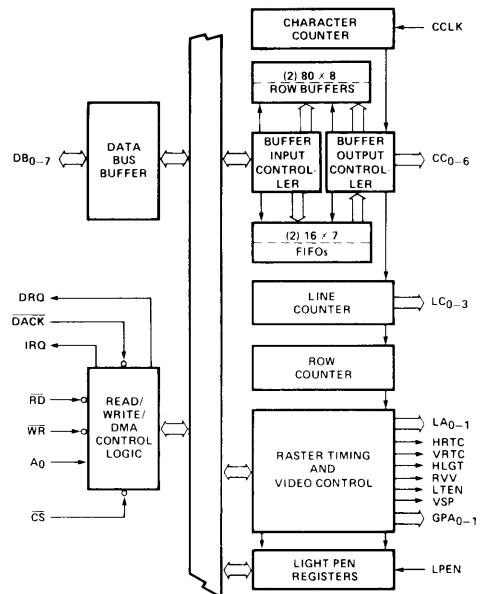

8279/8279-5 PROGRAMMABLE KEYBOARD/DISPLAY INTERFACE

- MCS-85™ Compatible 8279-5
- Simultaneous Keyboard Display Operations
- Scanned Keyboard Mode
- Scanned Sensor Mode
- Strobed Input Entry Mode
- 8-Character Keyboard FIFO
- 2-Key Lockout or N-Key Rollover with Contact Debounce
- Dual 8- or 16-Numerical Display
- Single 16-Character Display
- Right or Left Entry 16-Byte Display RAM
- Mode Programmable from CPU
- Programmable Scan Timing
- Interrupt Output on Key Entry

The Intel® 8279 is a general purpose programmable keyboard and display I/O interface device designed for use with Intel® microprocessors. The keyboard portion can provide a scanned interface to a 64-contact key matrix. The keyboard portion will also interface to an array of sensors or a strobed interface keyboard, such as the hall effect and ferrite variety. Key depressions can be 2-key lockout or N-key rollover. Keyboard entries are debounced and strobed in an 8-character FIFO. If more than 8 characters are entered, overrun status is set. Key entries set the interrupt output line to the CPU.

The display portion provides a scanned display interface for LED, incandescent, and other popular display technologies. Both numeric and alphanumeric segment displays may be used as well as simple indicators. The 8279 has 16X8 display RAM which can be organized into dual 16X4. The RAM can be loaded or interrogated by the CPU. Both right entry, calculator and left entry typewriter display formats are possible. Both read and write of the display RAM can be done with auto-increment of the display RAM address.

PIN CONFIGURATION

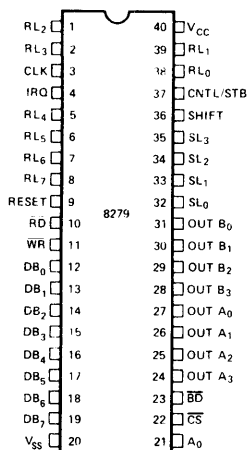

PIN NAMES

DB ₀₋₇	I/O	DATA BUS (BI DIRECTIONAL)
CLK	I	CLOCK INPUT
RESET	I	RESET INPUT
CS	I	CHIP SELECT
RD	I	READ INPUT
WR	I	WRITE INPUT
A ₀	I	BUFFER ADDRESS
IRQ	O	INTERRUPT REQUEST OUTPUT
SL ₀₋₃	O	SCAN LINES
RL ₀₋₇	I	RETURN LINES
SHIFT	I	SHIFT INPUT
CNTL/STB	I	CONTROL STROBE INPUT
OUT A ₀₋₃	O	DISPLAY (A) OUTPUTS
OUT B ₀₋₃	O	DISPLAY (B) OUTPUTS
BD	O	BLANK DISPLAY OUTPUT

LOGIC SYMBOL

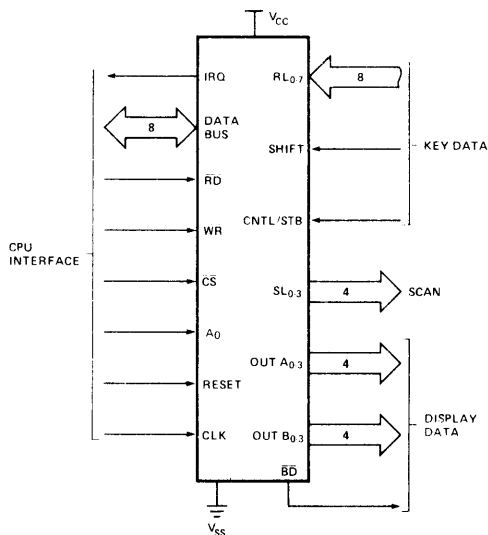

8291 GPIB TALKER/LISTENER

- Designed to Interface Microprocessors (e.g., 8080, 8085, 8086, 8048) to an IEEE Standard 488 Digital Interface Bus
- Programmable Data Transfer Rate
- Complete Source and Acceptor Handshake
- Complete Talker and Listener Functions with Extended Addressing
- Service Request, Parallel Poll, Device Clear, Device Trigger, Remote/Local Functions
- Selectable Interrupts
- On-Chip Primary and Secondary Address Recognition
- Automatic Handling of Addressing and Handshake Protocol
- Provision for Software Implementation of Additional Features
- 1 – 8 MHz Clock Range
- 16 Registers (8 Read, 8 Write), 2 for Data Transfer, the Rest for Interface Function Control, Status, etc.
- Directly Interfaces to External Non-Inverting Transceivers for Connection to the GPIB
- Provides Three Addressing Modes, Allowing the Chip to be Addressed Either as a Major or a Minor Talker/Listener with Primary or Secondary Addressing
- DMA Handshake Provision Allows for Bus Transfers without CPU Intervention
- Trigger Output Pin
- On-Chip EOS (End of Sequence) Message Recognition Facilitates Handling of Multi-Byte Transfers

The 8291 GPIB Talker/Listener is a microprocessor-controlled chip designed to interface microprocessors (e.g., 8048, 8080, 8085, 8086) to an IEEE Standard 488 Instrumentation Interface Bus. It implements all of the Standard's interface functions except for the controller.

PIN CONFIGURATION

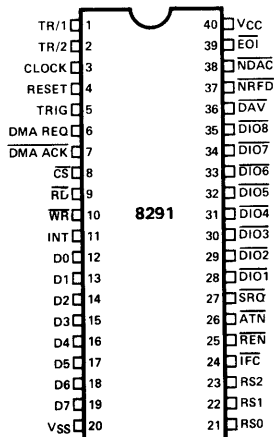

BLOCK DIAGRAM

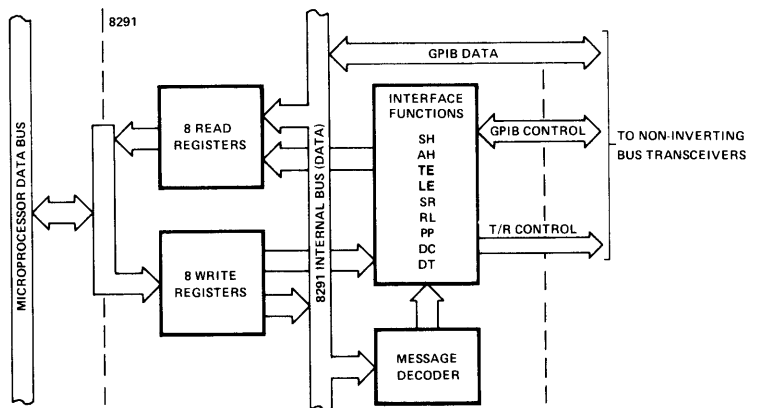

8292 GPIB CONTROLLER

FEATURES:

- Complete IEEE Standard 488 Controller Function.
- Interface Clear (IFC) Sending Capability Allows for Seizure of Control and/or Initialization of the Bus.
- Responds to Service Requests (SRQ).
- Sends (REN), Allowing Instruments to Switch to Remote Control.
- Complete Implementation of Transfer Control Protocol.
- Synchronous Control Seizure Prevents the Destruction of any Data Transmission in Progress.
- Connects with the 8291 to Form a Complete IEEE Standard 488 Interface Talker/Listener/Controller.

The 8292 GPIB CONTROLLER is a microprocessor-controlled chip designed to connect with the 8291 GPIB TALKER/LISTENER to implement the full IEEE Standard 488 controller function, including transfer control protocol. The 8292 is a pre-programmed UPI-41A™

PIN CONFIGURATION

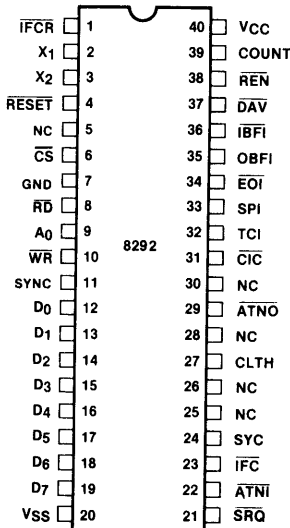

8291, 8292 SYSTEM DIAGRAM

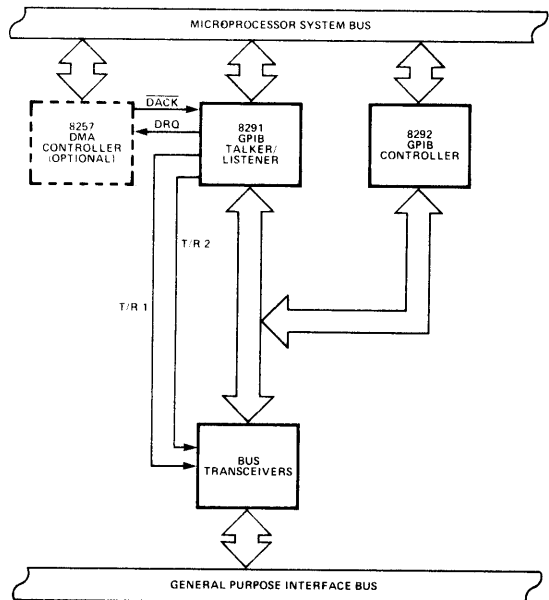

8293 GPIB TRANSCEIVER

- Nine Open-collector or Three-state Line Drivers
- 48 mA Sink Current Capability on Each Line Driver
- Nine Schmitt-type Line Receivers
- High Capacitance Load Drive Capability
- Single 5V Power Supply
- 28-Pin Package
- Low Power HMOS Design
- On-chip Decoder for Mode Configuration
- Power Up/Power Down Protection to Prevent Disrupting the IEEE Bus
- Connects with the 8291 and 8292 to Form an IEEE Standard 488 Interface Talker/Listener/Controller with no Additional Components
- Only Two 8293's Required per GPIB Interface

The Intel® 8293 GPIB Transceiver is a high current, non-inverting buffer chip designed to interface the 8291 GPIB Talker/Listener or the 8292 GPIB Controller with the 8291 to the IEEE Standard 488-1978 Instrumentation Interface Bus. Each GPIB interface would contain two 8293 Bus Transceivers. In addition, the 8293 can also be used as a general purpose bus driver.

PIN CONFIGURATION

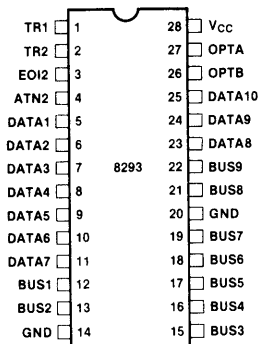

8291, 8292, 8293 SYSTEM DIAGRAM

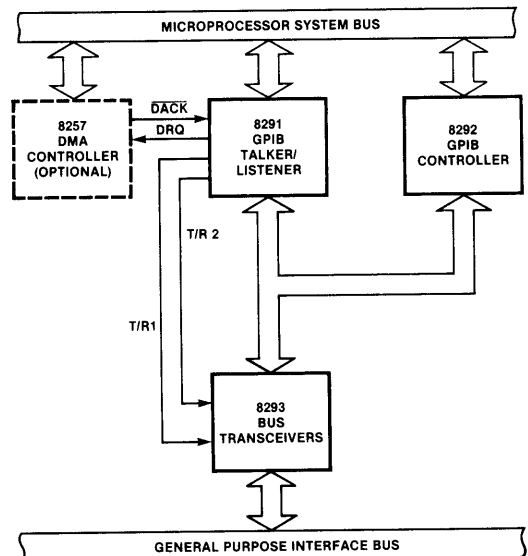

8294 DATA ENCRYPTION UNIT

- Certified by National Bureau of Standards
- 80 Byte/Sec Data Conversion Rate
- 64-Bit Data Encryption Using 56-Bit Key
- DMA Interface
- 3 Interrupt Outputs to Aid in Loading and Unloading Data
- 7-Bit User Output Port
- Single 5V ± 10% Power Supply
- Peripheral to MCS-86™, MCS-85™, MCS-80™ and MCS-48™ Processors
- Implements Federal Information Processing Data Encryption Standard
- Encrypt and Decrypt Modes Available

DESCRIPTION

The Intel® 8294 Data Encryption Unit (DEU) is a microprocessor peripheral device designed to encrypt and decrypt 64-bit blocks of data using the algorithm specified in the Federal Information Processing Data Encryption Standard. The DEU operates on 64-bit text words using a 56-bit user-specified key to produce 64-bit cipher words. The operation is reversible: if the cipher word is operated upon, the original text word is produced. The algorithm itself is permanently contained in the 8294; however, the 56-bit key is user-defined and may be changed at any time.

The 56-bit key and 64-bit message data are transferred to and from the 8294 in 8-bit bytes by way of the system data bus. A DMA interface and three interrupt outputs are available to minimize software overhead associated with data transfer. Also, by using the DMA interface two or more DEUs may be operated in parallel to achieve effective system conversion rates which are virtually any multiple of 80 bytes/second. The 8294 also has a 7-bit TTL compatible output port for user-specified functions.

Because the 8294 implements the NBS encryption algorithm it can be used in a variety of Electronic Funds Transfer applications as well as other electronic banking and data handling applications where data must be encrypted.

PIN CONFIGURATION

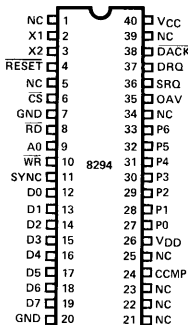

PIN NAMES

PIN NAME	FUNCTION
D ₇ -D ₀	DATA BUS
RD, WR	READ, WRITE STROBES
CS	CHIP SELECT
A ₀	CONTROL/DATA SELECT
RESET	RESET INPUT
X ₁ , X ₂	FREQUENCY REFERENCE INPUT
SYNC	HIGH FREQUENCY OUTPUT
DRQ, DACK	DMA REQUEST, DMA ACKNOWLEDGE
SRQ, OAV, CCMP	INTERRUPT REQUEST OUTPUTS
P ₆ -P ₀	OUTPUT PORT LINES
V _{CC} , V _{DD} , GND	+ 5V POWER, GND
NC	NO CONNECTION

BLOCK DIAGRAM

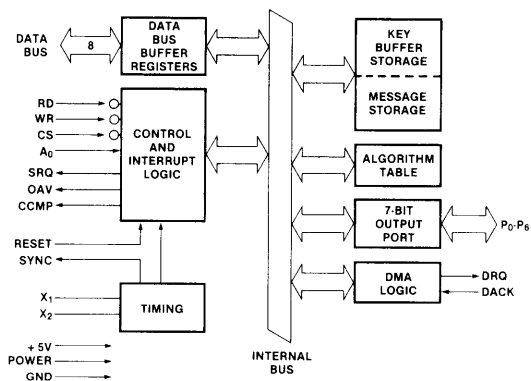

8295 DOT MATRIX PRINTER CONTROLLER

PRELIMINARY

Notice: This is not a final specification. Some parameters limits are subject to change.

- Interfaces Dot Matrix Printers to MCS-48™, MCS-80/85™, MCS-86™ Systems
- 40 Character Buffer On Chip
- Serial or Parallel Communication with Host
- DMA Transfer Capability
- Programmable Character Density (10 or 12 Characters/Inch)
- Programmable Print Intensity
- Single or Double Width Printing
- Programmable Multiple Line Feeds
- 3 Tabulations
- 2 General Purpose Outputs

The Intel® 8295 Dot Matrix Printer Controller provides an interface for microprocessors to the LRC 7040 Series dot matrix impact printers. It may also be used as an interface to other similar printers.

The chip may be used in a serial or parallel communication mode with the host processor. In parallel mode, data transfers are based on polling, interrupts, or DMA. Furthermore, it provides internal buffering of up to 40 characters and contains a 7 × 7 matrix character generator accommodating 64 ASCII characters.

