



## SECTION 1 GENERAL INFORMATION

### 1.1 INTRODUCTION

The Houston Instrument DMP-61 and DMP-62 digital plotters are the perfect answers for multi-size media plotting applications. Besides having high speed, intelligence, and durability, the DMP-60 series plotters enable you to plot on a wide variety of standard English and metric size charts.

This manual uses the term *plotter* when it provides general information about both models. The specific model terms *DMP-61* or *DMP-62* are used if information pertains only to that particular model.

A few of the features you'll find on your plotter are:

- DM/PL™ software protocol,
- Serial RS-232-C interface capabilities,
- Membrane control panel switches,
- English or metric scaling,
- A wide variety of paper size selections,
- 0.001 inch, 0.005 inch, 0.1 mm, or 0.025 mm user-addressable resolution,
- A menu mode, which enables you to select the plotter's power-up operating configuration,
- An extensive customer confidence test capability,

DM/PL is a trademark of AMETEK, Inc.



## GENERAL INFORMATION

---

### 1-2

- Window and scaling capabilities for manipulating the size or appearance of a plot,
- Plotter report capabilities,
- Ten different sets of character styles which can be produced in many different sizes, rotated to any slope, and printed in italics,
- A wide variety of axial plotting speeds which can be selected in either English or metric measures. Each selected velocity can be regulated at all angles with the constant velocity feature,

and more!

This manual provides:

- Instructions on how to set up and manually operate the plotter in local mode,
- Specifications to help you interface your plotter with your computer system,
- Descriptions of your plotter's DM/PL software capabilities.

1.2 SPECIFICATIONS

The plotter's specifications are listed in Table 1-1.

Table 1-1. DMP-60 SERIES SPECIFICATIONS	
ITEM	DESCRIPTION
<i>Plotter</i>	
DMP-61 Overall Height (including stand)	42 inches (1067 mm)
DMP-61 Width (including stand)	41 inches (1041 mm)
DMP-61 Depth (including stand)	27.5 inches (699 mm)
DMP-61 Weight (without stand)	30 pounds (13.6 kg)
DMP-61 Stand Weight	22 pounds (9.9 kg)
DMP-62 Overall Height (including stand)	51 inches (1295 mm)
DMP-62 Width (including stand)	52 inches (1321 mm)
DMP-62 Depth (including stand)	27 inches (686 mm)
DMP-62 Weight (without stand)	38 pounds (17.2 kg)
DMP-62 Stand Weight	30 pounds (13.6 kg)

## GENERAL INFORMATION

1-4

Table 1-1 (Continued). DMP-60 SERIES SPECIFICATIONS	
ITEM	DESCRIPTION
<i>Performance</i>	
Accuracy	On single-matte polyester (3 mil) at 18° – 30° C, 0.2% of move or 0.010 inch (0.254 mm), whichever is greater
DMP-61 Pen Up Plotting Speed	1–32 ips axial maximum (selectable)
DMP-61 Pen Down Plotting Speed	1–32 ips axial maximum (selectable)
DMP-62 Pen Up Plotting Speed	1–24 ips axial maximum (selectable)
DMP-62 Pen Down Plotting Speed	1–24 ips axial maximum (selectable)
DMP-61 Pen Up Acceleration	0.5 g, 1 g, 2 g, 3 g, or 4 g
DMP-62 Pen Up Acceleration	0.5 g, 1 g, or 2 g
DMP-61 Pen Down Acceleration	0.5 g, 1 g, 2 g, 3 g, or 4 g
DMP-62 Pen Down Acceleration	0.5 g, 1 g, or 2 g
Addressable Resolution	0.001 inch, 0.005 inch, 0.1 mm, or 0.025 mm
Repeatability (same pen)	±0.002 inch (0.05 mm)

**Table 1-1 (Continued).  
DMP-60 SERIES SPECIFICATIONS**

ITEM	DESCRIPTION
<i>Plotting Materials</i>	
Recommended Chart and Pen Type Combinations	H.I.-Frost and water-based hard nib or stainless steel drafting pens Matte film and tungsten tip drafting pens Vellum and stainless steel or tungsten tip drafting pens
DMP-61 Chart Sizes	Engineering A, B, C, and D Architectural A, B, C, and D DIN A4, A3, A2, and A1 Oversize DIN A4, A3, A2, and A1
DMP-62 Chart Sizes	Engineering A, B, C, D, E, and F Architectural A, B, C, D, E, F, and architectural 30 × 42 inches DIN A4, A3, A2, A1, A0, and B1 Oversize DIN A4, A3, A2, A1, and A0
Maximum Plot Areas	See Table 1-4

## GENERAL INFORMATION

1-6

Table 1-1 (Continued). DMP-60 SERIES SPECIFICATIONS	
ITEM	DESCRIPTION
<i>Interface</i>	
Interface Capability	Asynchronous serial RS-232-C
Plotter I/O Connector	Rear panel RS-232-C DB-25P
Mating Connector	RS-232-C DB-25S
Transmit Data Format (From Plotter)	7 data bits, 1 parity bit (selectable), 2 or more stop bits
Receive Data Format (To Plotter)	7 data bits, 1 parity bit (selectable), 1 or more stop bits
Baud Rate	300, 600, 1200, 2400, 4800, or 9600
Buffer	16K (standard), 1Mb (optional)
Firmware	DM/PL-compatible

## GENERAL INFORMATION

1-7

GENERAL INFORMATION

**Table 1-1 (Continued).  
DMP-60 SERIES SPECIFICATIONS**

ITEM	DESCRIPTION	
<i>Environmental</i>		
Operating Temperature	40° to 95° F (5° to 35° C)	
Relative Humidity	20% to 95% (non-condensing)	
<i>Power Requirements</i>		
<b>Nominal Line</b>	<b>Min/Max Line</b>	<b>Fuse</b>
100 Vac	89-108 Vac	1 Amp, Slo-Blo
120 Vac	108-130 Vac	1 Amp, Slo-Blo
220 Vac	197-238 Vac	0.5 Amp, Slo-Blo
240 Vac	216-260 Vac	0.5 Amp, Slo-Blo
48-62 Hz, single-phase, 85 VA max.		

## GENERAL INFORMATION

---

1-8

### 1.2.1 Supplies

The DMP-60 series plotter is a precision instrument designed to produce professional high-quality output. Its performance and plot quality are determined by the pens, inks, and media that you choose to use.

A wide variety of plotter supplies are available on the market. Unfortunately, the quality of those supplies varies. Houston Instrument has extensively researched and tested its approved line of pens, inks, and media. It's these supplies that allow your plotter to operate at peak performance.

The following supplies and accessories are recommended for use on your plotter and are available from Houston Instrument or from your local distributor. For listings of recommended pen type and media combinations for your plotter, see Sections 1.2 and 1.2.1, and *The Perfect Plot!* (part number MI-1098), which is supplied with your plotter.

#### Accessories

MP-60 Multi-Pen Changer Accessory

MP-60 Series Scanner Accessory

One-Megabyte Extended Buffer Board

**GENERAL INFORMATION**

1-9

**GENERAL INFORMATION**

<b>DOCUMENTATION</b>	
<b>PART NUMBER</b>	<b>DESCRIPTION</b>
MI-1110 MI-1044 MI-1116	DMP-60 Series Plotter Operation Manual DM/PL Command Language Manual DMP-60 Series Plotter Service Manual (available in June 1988)

<b>PLOTTING MEDIA</b>		
<b>PART NUMBER</b>	<b>DESCRIPTION</b>	<b>QUANTITY</b>
<i>A Size/Engineering Media</i> MC-3244 MC-3191 MC-3230 MC-3229 MC-3245	Vellum† Vellum H.I.-Vintage Clear Coated Film Presentation Bond	50 sheets 50 sheets 50 sheets 10 sheets 50 sheets
<i>B Size/Engineering Media</i> MC-3245 MC-3192 MC-3231 MC-3247	Vellum† Vellum H.I.-Vintage Presentation Bond	50 sheets 50 sheets 50 sheets 50 sheets

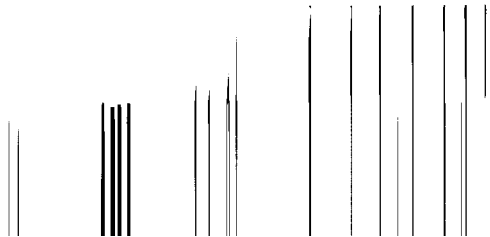

**GENERAL INFORMATION**

**1-10**

<b>PLOTTING MEDIA (Continued)</b>		
<b>PART NUMBER</b>	<b>DESCRIPTION</b>	<b>QUANTITY</b>
<i>C Size/Engineering Media</i>		
MC-3222	H.I.-Frost Paper	50 sheets
MC-3201	Matte Film	50 sheets
MC-3176	Vellum	50 sheets
MC-3248	Translucent Bond	50 sheets
MC-3249	Presentation Bond	50 sheets
<i>C Size/Architectural Media</i>		
MC-3204	Matte Film	50 sheets
MC-3251	Vellum	50 sheets
MC-3250	Translucent Bond	50 sheets
MC-3252	Presentation Bond	50 sheets
<i>D Size/Engineering Media</i>		
MC-3221	H.I.-Frost Paper	50 sheets
MC-3202	Matte Film	50 sheets
MC-3175	Vellum	50 sheets
MC-3253	Translucent Bond	50 sheets
MC-3254	Presentation Bond	50 sheets
<i>D Size/Architectural Media</i>		
MC-3220	H.I.-Frost Paper	50 sheets
MC-3203	Matte Film	50 sheets
MC-3187	Vellum	50 sheets
MC-3255	Translucent Bond	50 sheets
MC-3256	Presentation Bond	50 sheets

GENERAL INFORMATION

GENERAL  
INFORMATION

PLOTTING MEDIA (Continued)		
PART NUMBER	DESCRIPTION	QUANTITY
<i>E Size/Engineering Media</i>		
MC-3259	Matte Film	25 sheets
MC-3258	Vellum	25 sheets
MC-3257	Translucent Bond	50 sheets
<i>E Size/Architectural Media</i>		
MC-3242	Matte Film	25 sheets
MC-3241	Vellum	25 sheets
MC-3263	Translucent Bond	50 sheets
<i>30×42 inches Architectural Media</i>		
MC-3262	Matte Film	50 sheets
MC-3261	Vellum	50 sheets
MC-3260	Translucent Bond	50 sheets

## GENERAL INFORMATION

1-12

PENS AND PEN ACCESSORIES	
PART NUMBER	DESCRIPTION
<i>Stainless Steel Drafting Pens (Disposable)</i>	
MA-15	Adaptor for Disposable Drafting Pen
MP-729*	Red, fine point (0.35 mm)
MP-730*	Blue, fine point (0.35 mm)
MP-731*	Black, fine point (0.35 mm)
MP-732*	Green, fine point (0.35 mm)
MP-774*	Violet, fine point (0.35 mm)
MP-775*	Turquoise, fine point (0.35 mm)
MP-776*	Magenta, fine point (0.35 mm)
MP-737*	Red, broad point (0.70 mm)
MP-738*	Blue, broad point (0.70 mm)
MP-739*	Black, broad point (0.70 mm)
MP-740*	Green, broad point (0.70 mm)
MP-781*	Violet, broad point (0.70 mm)
MP-782*	Turquoise, broad point (0.70 mm)
MP-783*	Magenta, broad point (0.70 mm)
* Adaptor MA-15 not included	

PENS AND PEN ACCESSORIES (Continued)	
PART NUMBER	DESCRIPTION
<i>Disposable Drafting Pen Kits</i>	
PK-8097	Kit includes: one 0.35 mm black, one 0.35 mm red, one 0.35 mm blue, one 0.35 mm green, one MA-15 pen adaptor, and four caps
PK-8103	Kit includes: one each of black, red, blue, green, violet, turquoise, and magenta in fine and broad points; 14 each MA-15 adaptors; and 14 each caps
<i>Tungsten Tip Drafting Pens (Refillable)</i>	
MP-602	Mounting adaptor and pen body without pen tip
MP-659	Tungsten drafting pen tip (0.35 mm)
MP-660	Tungsten drafting pen tip (0.50 mm)
MP-661	Tungsten drafting pen tip (0.70 mm)
<i>Drafting Ink (One Ounce Bottles)</i>	
MI-117	Blue (slow drying)
MI-118	Red (slow drying)
MI-119	Green (slow drying)
MI-121	Blue (fast drying)
MI-122	Red (fast drying)

## GENERAL INFORMATION

1-14

PENS AND PEN ACCESSORIES (Continued)	
PART NUMBER	DESCRIPTION
<i>Water-Based Hard Nib Pens</i>	
MP-630	Red
MP-631	Blue
MP-632	Green
MP-633	Violet
MP-634	Brown
MP-635	Orange
MP-636	Black
MP-637	Lime Green
MP-638	Yellow
MP-639	Turquoise
<i>Water-Based Hard Nib Pen Kits</i>	
MP-640	Kit includes: one each of black, red, blue, green, violet, and orange
MP-641	Kit includes: one each of black, red, blue, green, violet, brown, lime green, and orange

**1.2.1.1 Plotter Supply Compatibility**

Houston Instrument offers a wide variety of pens and media for different types of plotting applications. Please note that not all pens may be used with all plotting materials. For best results, refer to the following chart and to *The Perfect Plot!* (part number MI-1098), which is supplied with your plotter, before ordering plotting supplies to see which plotting materials are recommended for use with any given pen type. A star (☆) in a chart column means that particular material may be used with a given pen type.

PLOTting MATERIAL	PEN TIP TYPE		
	STAINLESS STEEL	TUNGSTEN	HARD NIB (PLASTIC)
Vellum	☆	☆	
Matte Film		☆	
Clear Coated Film			☆
Presentation Bond			☆
Translucent Bond	☆		☆
H.I.-Frost	☆		☆
H.I.-Vintage			☆

## GENERAL INFORMATION

1-16

### 1.3 FLOOR STAND ASSEMBLY

#### CAUTION

Do not operate the plotter until after you have assembled the floor stand and attached the plotter to it. Otherwise, damage to the plotter or the plotting materials can result.

The assembly instructions for the floor stand are included in the floor stand kit. Complete the stand assembly and attach the plotter to it before proceeding with the instructions in this manual.

### 1.4 REAR AND BOTTOM PANEL COMPONENTS

Read through the following descriptions of the rear and bottom panel controls and components and familiarize yourself with the plotter. The location of each component is illustrated in Figure 1-1.

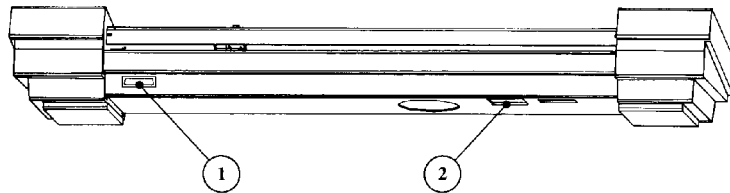
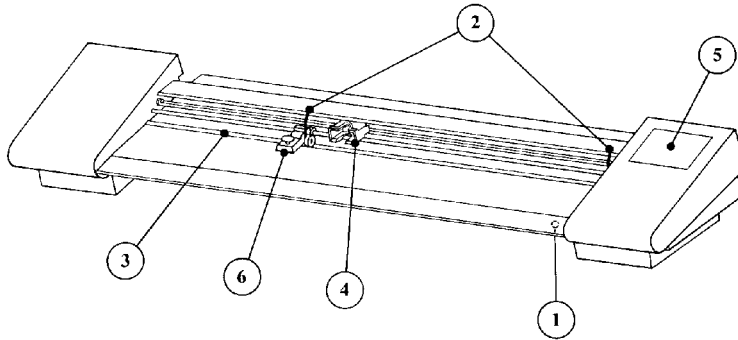

Figure 1-1.  
REAR AND BOTTOM VIEW OF PLOTTER

- ① RS-232-C PORT CONNECTOR. This DB-25P connector is the communication link between the plotter and a host computer. Interface instructions are listed in Section 1.9.
- ② AC FUSE CAVITY. The fuse, the voltage select board, and the receptacle for the ac power cord are located in the fuse cavity assembly. Section 1.6 explains how to power up the plotter. To convert the plotter's operating voltage, see Section 3.2.

**1.5 FRONT PANEL COMPONENTS**

Read through the following descriptions of the front panel controls and components and familiarize yourself with the plotter. The location of each component is illustrated in Figure 1-2.



**Figure 1-2.**  
**FRONT VIEW OF PLOTTER**

## GENERAL INFORMATION

---

### 1-18

- ① **POWER SWITCH.** This rocker switch sets the plotter's power to on or off. When the power is on, the "1" indicator is visible on the switch. If the power is off, the "0" indicator is visible.
- ② **PINCH ROLLER LEVER ARMS.** These two levers are used to raise and lower the pinch rollers from the chart drive shaft during media loading. (Media loading is discussed in Section 1.7.)
- ③ **CHART DRIVE SHAFT.** When the plotter is operated in plot origin right (large chart format), this shaft drives the chart in the X direction. When the plotter is operated in plot origin left (small chart format), the shaft drives the chart in the Y direction. (Large and small chart formats are discussed in Section 1.7.) The drive shaft moves the media only when the pinch rollers are lowered to the shaft.
- ④ **PEN HOLDER.** The pen holder is the mount for the plotter pen. The pen holder moves the pen in the Y direction when the plotter is operated in large chart format and in the X direction when the plotter is operated in the small chart format. Section 1.8 explains how to install pens in the pen holder.
- ⑤ **CONTROL PANEL.** The control panel consists of 12 keys and four illuminating (on/off) LED indicators. All plotter activity must be initiated from the control panel functions. This includes initiating remote mode for computer control, local mode for manual operation of the pen and media, menu mode, and selecting window and scale box limit coordinates. Each control panel function is explained in Section 2.1. The four LEDs indicate certain operating and error conditions, which are explained in Appendix A.
- ⑥ **THUMBSCREW.** When this thumbscrew is loosened, the left pinch roller assembly can be moved to a different chart size marker. When the thumbscrew is tightened, it secures the left pinch roller assembly to the platen. (Media loading is discussed in Section 1.7.)

1.6 POWERING UP THE PLOTTER

NOTE

Safety Ground Installation: An insulated grounding conductor that is identical in size, insulation material, and thickness to the grounded and ungrounded branch-circuit supply conductors except that it is green with or without one or more yellow stripes should be installed as part of the branch circuit that supplies power to the wall outlet.

The grounding conductor described above is to be grounded to earth at the electrical service equipment, or if supplied by a separately derived system, the grounding conductor should be at the supply transformer motor-generator set.

The attachment plug receptacles in the vicinity of the unit are all to be of a grounding type, and the grounding conductors serving these receptacles are to be connected to earth ground of the service equipment.

Do not attach the power cord to the plotter or to a power source until after you have determined the plotter's operating voltage setting (100, 120, 220, or 240 Vac).

To check the voltage setting, look through the bottom panel fuse cavity window at the number on the voltage select board. This number will be either 100, 120, 220, or 240 and represents the present voltage setting. If the number does not match the rating of your power source, see Section 3.2 and change the voltage setting and fuse rating before powering up the plotter.

The plotter's ground circuitry protects you from electrical shock. However, this protection is effective only if the ac outlet to be used is properly grounded to earth. If the plotter is to be connected to a two-contact wall outlet, a 3/2 adaptor with grounding lug/wire may be used. This type of connection is illustrated in Figure 1-3.

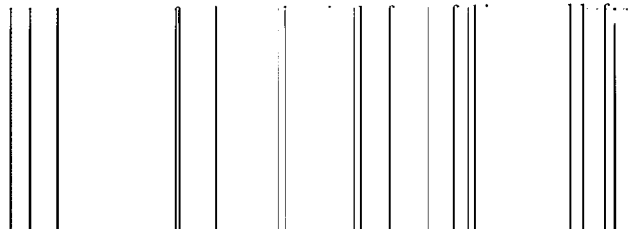

## GENERAL INFORMATION

1-20

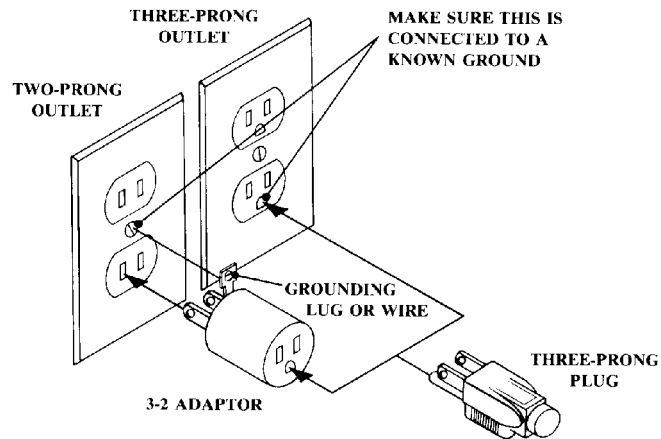

Figure 1-3.  
GROUND CONNECTION

### WARNING

To prevent personal injury when operating the plotter, keep your hands, hair, and clothing away from the platen and the chart drive shaft.



## GENERAL INFORMATION

---

### 1-22

Table 1-2a lists the DMP-61 power up default values. The DMP-62 power up default values are listed in Table 1-2b. (The values in parentheses are selected at the factory. If this value is not suitable for your applications, you can change the value as explained in Section 2.4.)

#### NOTE

The DMP-61 maximum pen down velocity is 32 ips. However, this velocity has been set in the menu at the factory to 24 ips to ensure best plot quality with all media/pen combinations. Refer to *The Perfect Plot!* (part number MI-1098) for more information on plot specifications for different media/pen combinations.

Table 1-2a.  
DMP-61 FIXED AND MENU-SELECTABLE DEFAULT VALUES

DEFAULT VALUE	TYPE
Plotter deselected	fixed
Remote mode active	fixed
Maximum window limits	fixed
Maximum scale box limits	fixed
Horizontal text path	fixed
Character size 8	fixed
Text italics (off)	fixed
Pen up velocity (32 ips)	Menu-selectable
Pen up acceleration (4 g)	Menu-selectable
Pen up delay (30ms)	Menu-selectable
Pen down velocity (24 ips)	Menu-selectable
Pen down acceleration (4 g)	Menu-selectable
Pen down delay (50ms)	Menu-selectable
Pen change (ignore)	Menu-selectable
Plot origin (auto)	Menu-selectable
Constant velocity option (on)	Menu-selectable
Addressing resolution (0.001 inch)	Menu-selectable
Menu units (English)	Menu-selectable
Text font (F0)	Menu-selectable
Character set (G0)	Menu-selectable
Auto-pen capping (disable)	Menu-selectable
Baud rate (9600)	Menu-selectable
UART parity (bit 8=0)	Menu-selectable
Handshake RTS/DTR (toggle)	Menu-selectable
Pass-through port option (toggle)	Menu-selectable
Number of pens (6)	Menu-selectable
Zero character (plain)	Menu-selectable

## GENERAL INFORMATION

1-24

<b>Table 1-2b.</b> <b>DMP-62 FIXED AND MENU-SELECTABLE DEFAULT VALUES</b>	
<b>DEFAULT VALUE</b>	<b>TYPE</b>
Plotter deselected	fixed
Remote mode active	fixed
Maximum window limits	fixed
Maximum scale box limits	fixed
Horizontal text path	fixed
Character size 8	fixed
Text italics (off)	fixed
Pen up velocity (24 ips)	Menu-selectable
Pen up acceleration (2 g)	Menu-selectable
Pen up delay (30ms)	Menu-selectable
Pen down velocity (24 ips)	Menu-selectable
Pen down acceleration (2 g)	Menu-selectable
Pen down delay (50ms)	Menu-selectable
Pen change (ignore)	Menu-selectable
Plot origin (auto)	Menu-selectable
Constant velocity option (on)	Menu-selectable
Addressing resolution (0.001 inch)	Menu-selectable
Menu units (English)	Menu-selectable
Text font (F0)	Menu-selectable
Character set (G0)	Menu-selectable
Auto-pen capping (disable)	Menu-selectable
Baud rate (9600)	Menu-selectable
UART parity (bit 8=0)	Menu-selectable
Handshake RTS/DTR (toggle)	Menu-selectable
Pass-through port option (toggle)	Menu-selectable
Number of pens (6)	Menu-selectable
Zero character (plain)	Menu-selectable
Comm errors (ignore)	Menu-selectable

**NOTE**

Read the remainder of this manual and follow its instructions before attempting to operate the plotter.

**1.7 MEDIA LOADING**

**WARNING**

To prevent personal injury when operating the plotter, keep your hands, hair, and clothing away from the platen and the chart drive shaft.

The media for your plotter is packaged in airtight plastic wrapping. After opening the package, let smaller size media sit for at least 15 minutes before using and larger size media for at least 30 minutes. This allows the media to stabilize to the surrounding humidity. (If the media is not allowed to stabilize to the environment before use, the resulting plot may have mismatched lines, line shifts or offsets. This is a result of the media expanding and contracting during plotting.) Handle the chart by its edges only! Fingerprints leave a slight residue on the media which may cause the pens to skip over those areas.

Both plotter models have arrow markers on their platen to which the left pinch roller assembly can be moved (see Figure 1-5). The DMP-61 has eight markers and the DMP-62 has 15 markers. By using the menu to rotate the plot origin to the right or left, all of the positions on the DMP-61 and most of the positions on the DMP-62 can accommodate a *small* chart or a *large* chart. A small (half) chart orientation exists when the length of the pen axis is longer than the length of the chart axis. A large (full) chart orientation exists when the length of the chart axis is longer than the length of the pen axis.

## GENERAL INFORMATION

---

### 1-26

The DMP-60 also enables you to cut a standard sheet of chart media into a non-standard size and plot on it. The only restrictions for using non-standard chart sizes are:

- The right-to-left length of the chart along the platen must be a standard size. The chart must be aligned with the front loading groove when it is installed in the plotter.
- The front-to-back length of the chart must be greater than eight inches and less than 50 inches.
- The maximum plot area obtained will be approximately 1.2 inches less than the chart dimensions in both directions.

The DMP-61 standard chart sizes for each position are listed in Table 1-3a. Table 1-3b lists the standard chart sizes for the DMP-62. (The chart size positions are referenced from right-to-left in this section.) The maximum plot areas for the charts are listed in Table 1-4.

The menu also has an option which allows the plotter to automatically select the correct plot origin for a particular chart. The menu parameters and options are explained in Section 2.4.

#### NOTE

For proper operation, use only media that is flat and does not curl.

TABLE 1-3a. DMP-61 STANDARD CHART SIZES

PLATEN MARKER	LEFT PLOT ORIGIN (Small Chart)	RIGHT PLOT ORIGIN (Large Chart)
Position 1 (Engineering A — B)	Engineering A 8.5 inches × 11 inches	Engineering B 11 inches × 17 inches
Position 2 (A4 — A3 DIN)	A4 DIN 210 mm × 297 mm	A3 DIN 297 mm × 420mm
Position 3 (Architectural A — B)	Architectural A 9 inches × 12 inches	Architectural B 12 inches × 18 inches
Position 4 (Oversize A4 — A3)	Oversize A4 240 mm × 330 mm	Oversize A3 330 mm × 450 mm
Position 5 (Engineering C — D)	Engineering C 17 inches × 22 inches	Engineering D 22 inches × 34 inches
Position 6 (A2 — A1 DIN)	A2 DIN 420 mm × 594 mm	A1 DIN 594 mm × 841 mm
Position 7 (Architectural C — D)	Architectural C 18 inches × 24 inches	Architectural D 24 inches × 36 inches
Position 8 (Oversize A2 — A1)	A2 Oversize 450 mm × 625 mm	A1 Oversize 625 mm × 880 mm

## GENERAL INFORMATION

1-28

Table 1-3b. DMP-62 STANDARD CHART SIZES		
PLATEN MARKER	LEFT PLOT ORIGIN (Small Chart)	RIGHT PLOT ORIGIN (Large Chart)
Position 1 (Engineering A — B)	Engineering A 8.5 inches × 11 inches	Engineering B 11 inches × 17 inches
Position 2 (A4 — A3 DIN)	A4 DIN 210 mm × 297 mm	A3 DIN 297 mm × 420mm
Position 3 (Architectural A — B)	Architectural A 9 inches × 12 inches	Architectural B 12 inches × 18 inches
Position 4 (Oversize A4 — A3)	Oversize A4 240 mm × 330 mm	Oversize A3 330 mm × 450 mm
Position 5 (Engineering C — D)	Engineering C 17 inches × 22 inches	Engineering D 22 inches × 34 inches
Position 6 (A2 — A1 DIN)	A2 DIN 420 mm × 594 mm	A1 DIN 594 mm × 841 mm
Position 7 (Architectural C — D)	Architectural C 18 inches × 24 inches	Architectural D 24 inches × 36 inches
Position 8 (Oversize A2 — A1)	A2 Oversize 450 mm × 625 mm	A1 Oversize 625 mm × 880 mm

**GENERAL INFORMATION**

1-29

**GENERAL  
INFORMATION****Table 1-3b (Continued).  
DMP-62 STANDARD CHART SIZES**

<b>PLATEN MARKER</b>	<b>LEFT PLOT ORIGIN (Small Chart)</b>	<b>RIGHT PLOT ORIGIN (Large Chart)</b>
Position 9 (B1 DIN)	---	B1 DIN 707 mm × 1000 mm
Position 10 (Architectural/Engineering F)	Architectural/Engineering F 28 inches × 40 inches	---
Position 11 (Architectural 30 × 42)	---	Architectural 30/42 30 inches × 42 inches
Position 12 (A0 DIN)	---	A0 DIN 841 mm × 1189 mm
Position 13 (Engineering E)	---	Engineering E 34 inches × 44 inches
Position 14 (Oversize A0)	---	Oversize A0 880 mm × 1230 mm
Position 15 (Architectural E)	---	Architectural E 36 inches × 48 inches

## GENERAL INFORMATION

---

### 1-30

The following procedure explains how to install charts. The RESET and LOAD LED indicators will flash on and off during this procedure. This signal indicates that the plotter is out of media. After the chart is properly inserted and then loaded by pressing the RESET or the LOAD key, the signal will stop.

#### NOTE

The plotter uses vacuum to keep the center area of the media clear of the pen. The vacuum motor is activated by the plotter's power switch.

1. Raise the pinch roller arm of the left pinch roller assembly. Loosen the thumbscrew on top of the left pinch roller assembly by turning it counter-clockwise until the pinch roller assembly can slide freely on the beam (see Figure 1-4).

#### CAUTION

Be sure to raise the left pinch roller assembly from the drum before moving the roller assembly to a different chart marker. Otherwise, the friction of the drum may create a flat spot on the roller wheel.

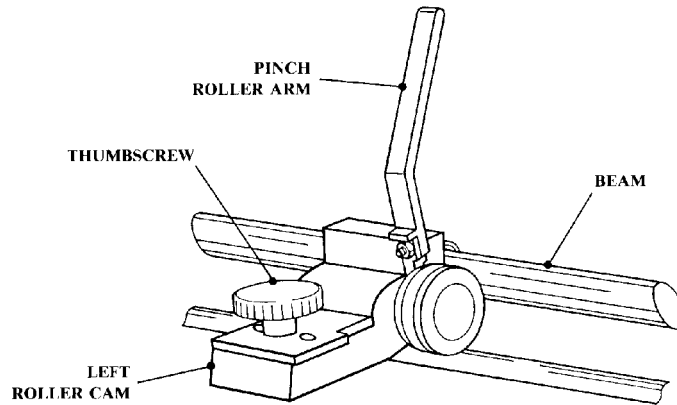
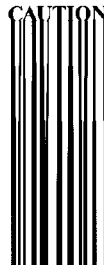

Figure 1-4.  
LEFT PINCH ROLLER ASSEMBLY THUMBSCREW

2. Each chart size marker indicates the location of a threaded hole on the platen (see Figure 1-5). The threaded holes are used to secure the left pinch roller assembly to the platen. Slide the left pinch roller assembly to the desired chart size marker. Be sure that the thumbscrew is aligned with the threaded hole, and then tighten the thumbscrew in the threaded hole by turning it clockwise until it is finger-tight.



## GENERAL INFORMATION

1-32

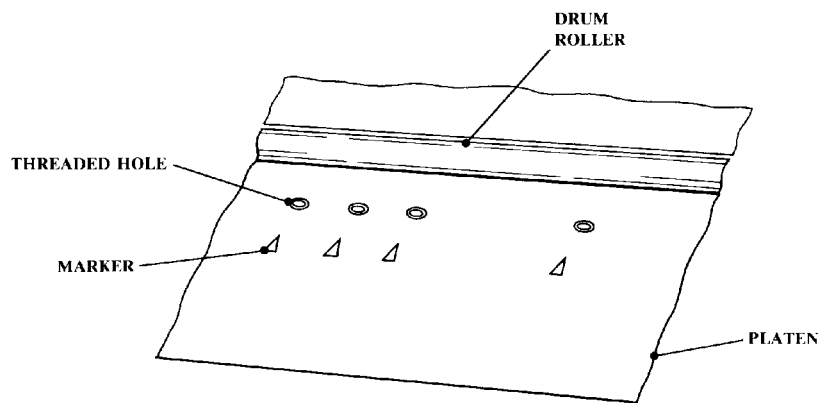

**Figure 1-5.**  
**CHART SIZE MARKERS AND THREADED HOLES ON PLATEN**

3. Raise the pinch roller arm of the right pinch roller assembly. Refer to Table 1-3a or 1-3b to determine if the chart size you are loading requires small chart (right plot origin) or large chart (left plot origin) format. If small chart format is required, insert the media as shown in Figure 1-6. If large chart format is required, insert the media as shown in Figure 1-7.



## GENERAL INFORMATION

---

### 1-34

4. Align the right front edge of the media with the groove on the platen and the white line on the right side of the platen. Lower the right pinch roller arm. Next, align the left front edge of the media with the loading groove on the platen, and then lower the left pinch roller arm. (Appendix D lists environmental considerations for the plotting media.)
5. Press the **LOAD** key. The plotter is set at the factory to automatically select the correct plot origin for the chart installed. It does this by first moving the pen holder to the right until it locates the right stop and then to the left until it locates the left stop. The pen holder then returns to the right side of the pen bar. The media is then moved forward until its rear edge is detected by the platen sensor, and is then returned to the load position. If the plotter senses that a chart is longer than it is wide, it automatically selects right plot origin, or large chart format. If it senses that the chart is wider than it is long, it selects left plot origin, or small chart format. (A left plot origin or a right plot origin can be manually specified in the menu to override the automatic chart size feature, if desired.)
6. The media is now properly loaded, and the **RESET** indicator will turn off and the **LOAD** indicator will illuminate.

#### NOTE

When installing or replacing media of any size, the chart *must* be aligned with the front loading groove before pressing the **RESET** or the **LOAD** key. The plotter assumes the front chart edge is at the groove and searches only for the rear chart edge.

The left pinch roller assembly can be moved to change media sizes at any time except when the plotter is drawing a plot or operating in menu mode (see Section 2.4). If the chart size is changed by more than one quarter-inch, the plotter will automatically reset when the **RESET** or the **LOAD** key is pressed.

Table 1-4 lists the maximum plotting area for each chart size.

Table 1-4.  
MAXIMUM PLOTTING AREAS

CHART SIZE	PLOT AREA	PLOT ORIGIN
Architectural A	7.8 × 10.8 inches	Left
Architectural B	10.8 × 16.8 inches	Right
Architectural C	16.8 × 22.8 inches	Left
Architectural D	22.8 × 34.8 inches	Right
Architectural E	34.8 × 46.8 inches	Right
Architectural F	26.8 × 38.8 inches	Right
Architectural 30 × 42 inches	28.8 × 40.8 inches	Right
Engineering A	7.3 × 9.8 inches	Left
Engineering B	9.8 × 15.8 inches	Right
Engineering C	15.8 × 20.8 inches	Left
Engineering D	20.8 × 32.8 inches	Right
Engineering E	32.8 × 42.8 inches	Right
Engineering F	26.8 × 38.8 inches	Right
DIN A4	179 × 266 mm	Left
DIN A3	266 × 389 mm	Right
DIN A2	389 × 563 mm	Left
DIN A1	563 × 810 mm	Right
DIN A0	810 × 1158 mm	Right
DIN B1	676 × 969 mm	Right
Oversize A4	209 × 299 mm	Left
Oversize A3	299 × 419 mm	Right
Oversize A2	419 × 594 mm	Left
Oversize A1	594 × 849 mm	Right
Oversize A0	849 × 1199 mm	Right

## GENERAL INFORMATION

---

1-36

### 1.8 PENS

The pens that are supplied with your plotter are disposable technical drafting pens specially designed for your plotter. A variety of pen tip sizes and other plotting accessories are listed in Section 1.2.1.

The following procedure explains how to install and use disposable technical pens.

1. Insert a pen tip into each ink cartridge and then place a cap on each pen. To use a pen for the first time, press downward on the pen cap to push the nib into the body of the ink cartridge to break its seal.

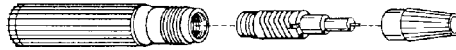

2. Remove and save the pen cap. Briskly shake the pen until you see ink flow between the ribs of the pen tip and the ink cartridge. If the ink does not appear, activate the pen again as described in the preceding step.

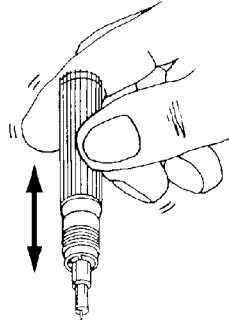

3. Hand draw on scrap H.I.-Frost or vellum to verify its operation.

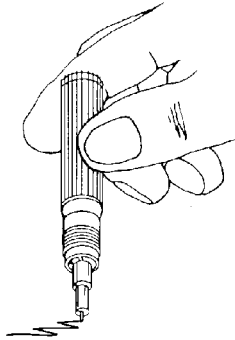

4. Screw the pens into the adaptors (the pens only fit into the adaptors the correct way). The pens are ready for use.

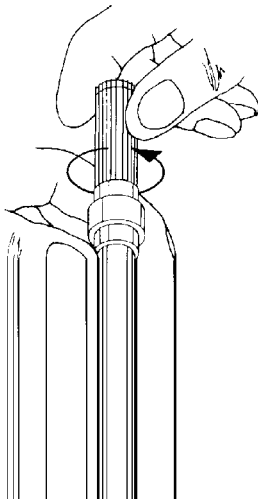

## GENERAL INFORMATION

1-38

5. When a pen is not in use, cap and store it in the storage box in a horizontal position. Use the short blue pen cap if the pen is in the adaptor. Use the long clear pen cap if the pen is not in the adaptor. Before using the pen again, sharply tap the pen body (not the tip) on a hard surface to restart the flow of ink.

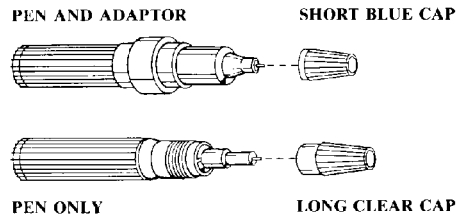

### 1.8.1 Pen Care

The following paragraphs describe the simple pen care requirements for the plotter pens.

All plotter pen types must be capped when not in actual use. If the plotter has the optional multi-pen changer accessory installed, the pens may be stored in the pen stalls. For long-term storage, you may also store the pens by removing them from the pen stalls, capping them with the provided caps, and sealing them in a plastic bag. Drafting pens that have been unused for a few days should be checked for ink flow before use, whether they have been individually capped or stored in a pen stall.

**1.8.1.1 Hard Nib Pen**

The hard nib pens are disposable pens that have no particular care requirements other than to keep them capped when not in actual use. Test the pen on a piece of scrap plotting material to verify operation.

A hard nib pen with dried ink can sometimes be saved by dipping the pen point in water, then rubbing the point on scrap media to restart ink flow.

**1.8.1.2 Disposable Stainless Steel Drafting Pen**

The stainless steel pens are disposable technical pens that have no particular care requirements other than to keep them capped when not in actual use. Cap the pen with the short blue cap if the pen is inserted in an adaptor as described in Section 1.8. Otherwise, cap the pen with the long clear cap.

You must first activate stainless steel pens before using them for the first time. This is explained in Section 1.8.

There are no special cleaning requirements for these pens. A stainless steel pen with dried ink can often be restarted by holding the pen point upward and sharply tapping the reservoir against a hard surface several times. Capping a dried pen for a few days may allow the ink to dissolve the clog. Also, these pens can often be restarted by dipping the pen point in water or an ultrasonic cleaner, then rubbing the point on scrap plotting media.

## GENERAL INFORMATION

---

### 1-40

#### 1.8.1.3 Tungsten Pen

The tungsten pens are refillable technical pens for plots on vellum or film. Refer to Figure 1-8. These pens should be capped when not in actual use. The pens are automatically capped when installed in the stable assembly of the multi-pen changer accessory. Like any technical drawing pen, these pens must be occasionally cleaned and filled with ink for proper operation.

To fill the pen, remove the pen reservoir and add ink, up to the fill line as shown in Figure 1-8. For best results, do not fill past this line. Also note that these pens should be refilled before the reservoir is empty. Test the pen on a piece of scrap plotting material to verify operation. If there is no ink flow, hold the pen tip downward and briskly shake the pen twice. Then install an adaptor on the pen body for use in the plotter.

#### CAUTION

If the pen tip is taken apart, be very careful not to bend the cleaning wire inside the tip.

There are no special cleaning requirements for these pens. As with any technical drawing pen, these may be disassembled and cleaned occasionally as needed using tap water or an ultrasonic cleaner. Then thoroughly dry the parts and reassemble the pen. Pen care products are available from any drafting supply store. Note that you should thoroughly clean a pen if you plan to use another ink color in it.

A tungsten pen with dried ink can sometimes be restarted by shaking the pen a few times with the pen tip pointing downward, or by holding the pen point upward and tapping the reservoir against a hard surface. Also, these pens can often be restarted by dipping the pen point in water or denatured alcohol, then rubbing the point on scrap plotting media.

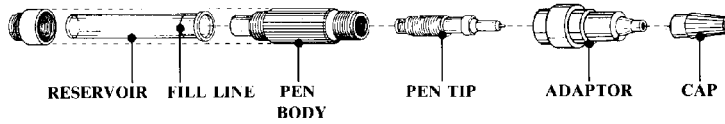

Figure 1-8.  
TUNGSTEN PEN

1.9 SERIAL RS-232-C INTERFACE

The serial RS-232-C interface enables the plotter to be connected to and controlled by an RS-232-C-compatible host computer system. The plotter is equipped with a standard RS-232-C DB-25P connector on its rear panel (see Figure 1-1) and requires a standard RS-232-C DB-25S mating connector.

The plotter's RS-232-C circuitry is considered as DTE type equipment, which means *the plotter always transmits data on pin 2 and receives data on pin 3*. Table 1-5 lists the active signals/pins on the plotter's RS-232-C connector and their direction of travel. Each signal is explained below.

## GENERAL INFORMATION

---

### 1-42

- Transmit Data, pin 2. The plotter uses this pin to transmit data to the computer while operating in DM/PL Mode One XON/XOFF or DM/PL Mode Two, or any DM/PL command that sends data to the computer.
- Receive Data, pin 3. The plotter *always* receives data from the computer on this pin.
- Request To Send (RTS), pin 4, and Data Terminal Ready (DTR), pin 20. These two pins are internally connected in the plotter. This signal is used during Mode One handshaking. A high signal level tells the computer that the plotter is ready for more data (the plotter buffer is not full). A low signal level tells the computer to wait until the plotter can accept more data (the buffer is full). Some computer models require a constant high signal level from these two pins. If this requirement applies to your computer, a constant high signal level at pin 4 (RTS) and pin 20 (DTR) can be specified from the menu (see Section 2.4).
- Signal Ground, pin 7. Required signal ground.

**Table 1-5.  
PLOTTER'S RS-232-C CONNECTOR SIGNALS (DTE)**

PIN NUMBER AND SIGNAL NAME	SIGNAL DIRECTION
PIN 1—Chassis (earth) ground	Common
PIN 2—Transmit data (TD)	From Plotter
PIN 3—Receive data (RD)	To Plotter
PIN 4—Request To Send (RTS)*	From Plotter
PIN 7—Signal (board) ground	Common
PIN 14—Auxiliary Receive Data†	From Plotter
PIN 16—Auxiliary Transmit Data†	To Plotter
PIN 20—Data Terminal Ready (DTR)*	From Plotter

\*Pins 4 and 20 are internally jumpered, and the signal levels can be specified from the menu to either toggle or remain high.

†See Section 1.9.1.

## GENERAL INFORMATION

---

### 1-44

The remainder of this section includes instructions on how to fabricate data cables for various types of handshaking and how to connect them to the plotter and the computer. Read this section thoroughly even if you have purchased our factory pre-fabricated cables—the information may be useful in the future if you decide to replace your computer system or use the plotter on another system that has a different handshake sequence. Before attempting to connect the plotter to your system, consult the computer owner's manual and determine what your computer's interface signal requirements are. (If your software gives a cable configuration, you must use that connection.) In general, you'll need to know:

- Which RS-232-C I/O port is recommended by your computer's manufacturer for use with other external equipment?
- Is your computer considered as DCE or DTE type equipment?
- What is the cable configuration that is required by your software to perform handshaking functions?
- Does your computer/modem require Request To Send (RTS) and/or Data Terminal Ready (DTR) signal response?

#### NOTE

If you have a problem interfacing the plotter and the computer, activate the plotter's communication error checking routine by entering the plotter menu and selecting the *REPORTED* option for the *COMM ERRORS* parameter (see Section 2.4). The communication error checking routine allows the plotter to detect and identify data line problems. If problems are detected, error codes are displayed on the control panel LEDs (see Appendix A). If the communication error routine is used, be sure the computer program does not use automatic baud rate selection (auto-baud). Otherwise, auto-baud will trigger unnecessary baud rate error codes as it attempts to match baud

After a good communication link has been established, deactivate the communication error checking routine by selecting the *IGNORE* option for the menu *COMM ERRORS* parameter. Although the plotter will operate with the routine activated, it is not necessary to have the routine active during normal operation.

If you did not purchase factory prefabricated data cables with your plotter, you may consider making a cable specifically for the type of handshake used by your computer and software before trying to set up a communication link using any spare RS-232-C cable that you may have. Because of the many misinterpretations of the RS-232-C "standards" in the commercial computer industry, a working cable on one system or software may prove useless on another.

Cable fabrication is inexpensive and requires very little technical skill. Your local dealer or electrical parts house can supply you with the cable wires, end connectors, and the tools you will need to construct a quality cable. When constructing a data cable, always shield each individual signal wire, as well as the entire cable, to prevent internal "cross-talk" and electrical noise from occurring. The mating connector for the plotter's rear panel connector must be an RS-232-C DB-25S connector. Your computer owner's manual will supply the type of mating connector required for your equipment. The overall length of a data cable should be limited to 15 feet (4.6 meters).

The number of signal wires required in your cable and the pin numbers on the end connector you should connect them to depends on the device type of your equipment (DCE or DTE) and the type of handshaking required. Figure 1-9 illustrates basic RS-232-C cabling techniques. Specific interface instructions for most of the computer models presently on the market are listed in Appendix E.

# GENERAL INFORMATION

1-46

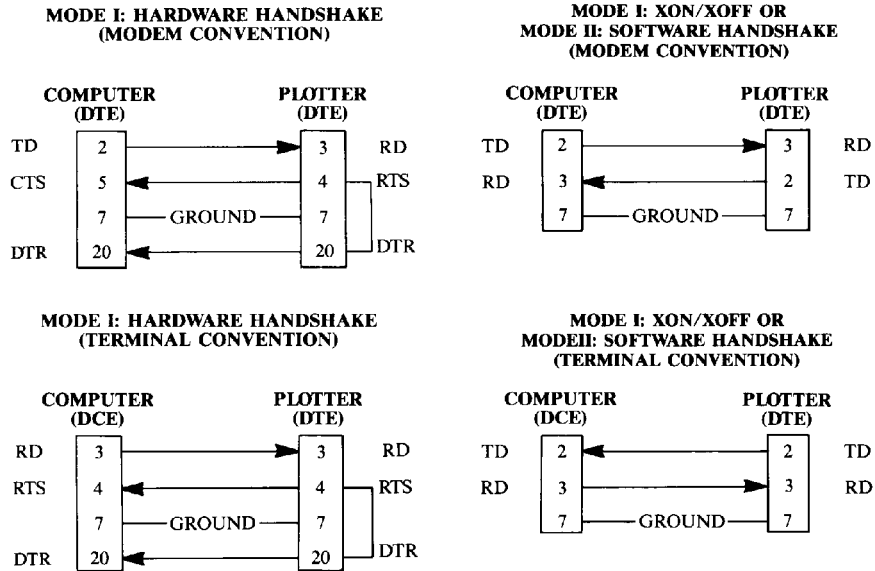
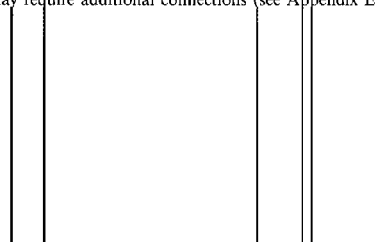

Figure 1-9.  
BASIC RS-232-C CABLING TECHNIQUES

**NOTES:**

1. These diagrams show the most common generic connections only. Your computer or software may require additional connections (see Appendix E).



**WARNING**

RS-232-C DB-25 connectors use pin 1 for chassis ground. Although this signal is not required for operation, its function is similar to the earth ground prong on three-contact ac plugs. Regardless of the type of cable you construct, it is highly recommended to always connect pin 1, chassis ground, at both end connectors.

Use the menu to specify baud rate and parity (see Section 2.4).

Before you connect the plotter to your computer system with the data cable, check the computer owner's manual for cabling precautions from its manufacturer, and power down the plotter. Plug one end of the data cable into the computer's RS-232-C I/O port connector, and then plug the other end of the cable into the plotter's rear panel RS-232-C data connector. Power up the plotter and then the computer system.

**1.9.1 (RS-232-C) Pass-Through Port Feature**

The pass-through port feature enables you to transmit the data received by the plotter from the host computer to an auxiliary CRT device.

To connect an auxiliary CRT device to the host computer/plotter configuration, three additional signal wires must be connected from the plotter's rear RS-232-C connector to the CRT. These signal connections are shown in Table 1-6.

## GENERAL INFORMATION

1-48

Table 1-6. RS-232-C PASS-THROUGH PORT SIGNAL CONNECTIONS			
COMPUTER SIGNAL PIN (DCE)		PLOTTER SIGNAL PIN (DTE)	AUXILIARY (CRT) SIGNAL PIN (DTE)
PIN 1 (CHS GRD)	TO	PIN 1 (CHS GRD)	TO PIN 1 (CHS GRND)
PIN 2 (RD)	TO	PIN 2 (TD)	
PIN 3 (TD)	TO	PIN 3 (RD)	
PIN 7 (SIG GRD)	TO	PIN 7 (SIG GRD)	TO PIN 7 (GRND)
		PIN 14 (ARD)	TO PIN 2 (ATD)
		PIN 16 (ATD)	TO PIN 3 (ARD)
<p>CHS GRD = Chassis Ground            RD = Receive data            TD = Transmit data            SIG GRD = Signal Ground            ARD = Auxiliary Receive Data            ATD = Auxiliary Transmit Data</p> <p>An illustration of this type of connection is shown in Figure 1-10.</p>			

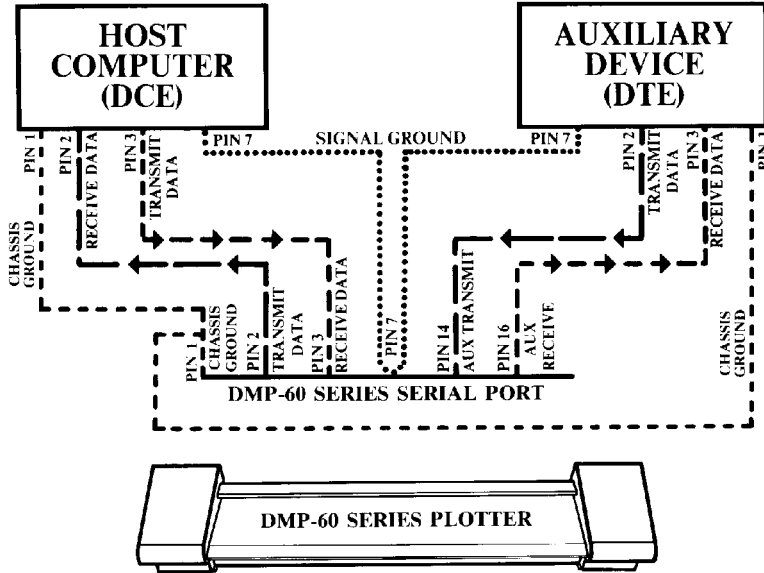

Figure 1-10. PASS-THROUGH PORT CONFIGURATION

## GENERAL INFORMATION

---

### 1-50

After the signal connections are made, the type of control you want for the pass-through port data from the plotter (pin 16) to the CRT (pin 3) can be specified in the menu (see Section 2.4). If the *ALWAYS ON* option is selected for the *PASS-THROUGH PORT* menu parameter, this feature will remain active. If the *TOGGLE* option is selected, this feature can be toggled on by using the DM/PL Pass-Through Port (X) command.

#### CAUTION

Use only pins 14, 16, and 7 to connect an auxiliary device to the plotter. If an auxiliary device is connected to the plotter and XON/XOFF (Mode One) handshaking is used, make certain that the device connected to the plotter's pass-through port does not transmit an XON/XOFF handshake while the plotter is operating. This may cause the host computer to respond to the wrong handshake signal and transmit erroneous plot codes.

#### 1.10 DIGITIZE MODE

Digitize mode enables the plotter to transmit the x-, y-coordinate of the present position of the pen to the computer for processing. This information is transmitted on pin 2 of the plotter's interface. Digitize mode must be activated by entering the DM/PL Digitize (ED) command from the computer (see your DM/PL manual).

Your computer must be programmed to receive the x-, y-coordinate data, which is ASCII BCD format, from the plotter. (Consult your computer's software manual for programming instructions.) The data from the plotter consists of two, six-digit, signed<sup>1</sup> coordinates in parentheses, followed by a carriage return <CR> terminator.

The following is an example of a digitized x-, y-coordinate data point:

( 001200, 000850) <CR >

After the plotter receives an ED command, it switches to local mode (the LOAD and LOCAL indicators are on) and the ENTER indicator flashes on and off. The ◀, ▲, ▶, and ▼ keys can then be used to move the pen to the location of the point to be digitized. (The CLIP LL, CLIP UR, SCALE LL, and SCALE UR keys can also be used to move the pen to the present window/scale box points.)

After the pen is positioned, press ENTER, and the plotter will transmit the position of the pen to the computer. The ENTER indicator will then turn off, and the plotter will beep and return to remote mode. (After the plotter enters remote mode, the pen will return to the location it was at prior to the ED command.) Repeat this procedure for each point to be digitized.

The following sample program demonstrates the use of the digitizing function of the plotter. The program is for an IBM PC™ using BASIC. Before running this program, use the plotter menu to set 9600 baud and even parity (see Section 2.4).

IBM PC:

```
20 OPEN "COM1:9600,E,7,2,CS,DS " AS #1
30 PRINT #1;" :: H"
40 FOR I = 1 TO 10
50 PRINT #1;"ED"
60 INPUT #1,X$,Y$
65 X=VAL(RIGHT$(X$,6));Y=VAL(LEFT$(Y$,6))
70 PRINT X,Y
80 NEXT I
90 PRINT #1;" Z"
100 END
```

Line 20 — configures the serial port for input and output

Line 30 — initializes the plotter and sends the pen to Home position

IBM PC is a trademark of the International Business Machines Corporation.

## GENERAL INFORMATION

---

1-52

Line 40 — FOR loop that allows ten points to be digitized

Line 60 — inputs x- and y-coordinates from the plotter

Line 65 — decodes x- and y-coordinates

Line 70 — prints x- and y-coordinates to the screen

Line 80 — NEXT statement for FOR loop in line 40

Line 90 — software resets the plotter at the end of the buffer

### 1.11 THE ONE-MEGABYTE EXTENDED BUFFER BOARD ACCESSORY

The extended buffer board accessory enables you to expand the plotter buffer by an additional one-megabyte. When data is received at the plotter's RS-232-C port, it is automatically stored in the extended buffer if one is installed.

To replot all of the data in the extended buffer, place the plotter in local mode by pressing the LOCAL key, and then press the ◀ and ▶ keys simultaneously. If the buffer is empty, the plotter will draw the Europlot design. The plotter will also draw the Europlot if a file larger than one megabyte is sent to the buffer.

To plot a string of files from the extended buffer, first clear all previous data from the buffer by pressing the RESET key. If you want each file to be plotted on separate charts, your software must include a DM/PL end of plot (e) command at the end of each file (see Section 4.4.9). (Some applications, such as multi-layered pc board plots, require different files to be plotted on the same chart. To create these types of plots, the software should not use the end of plot command in the plot code.)

To plot the first file in the string, press the LOCAL key and then the ◀ and ▶ keys simultaneously. After the first file is plotted, the DM/PL end of plot command will cause the DMP-60 to stop and flash the plot command condition code on the LEDs. (The plot command condition code causes the RESET LED to flash on and off as explained in Appendix A.) After changing charts, press the LOCAL key to continue. The plotter will automatically size the chart and begin plotting the next plot file stopping at each end of plot command until the buffer has been completely replotted. After the last file is plotted, the string of buffer files can then be restarted. If end of plot commands are not present, the buffer files will plot over each other. The buffer files must be plotted sequentially. For example, to plot buffer file number three, the two preceding files must be plotted first.

The extended buffer also enables you to plot one file several times without having to reload it each time from the computer. Reset the plotter to clear the buffer of all previous data. After you have loaded the file into the extended buffer, you can plot it as many times as you need by pressing LOCAL, and then ◀ and ▶ simultaneously. (Use only the LOAD key to load new media when changing charts. The RESET key will empty the extended buffer.)

To clear all data from the extended buffer, press the RESET key.

The extended buffer board RAM is checked by the plotter at each power up. If an error is detected in the RAM at power up, the LOAD and LOCAL indicators will flash on and off as shown below.

□   \*   \*   □

If a RAM error occurs, service is required (see Section 3.3).

