

## CHAPTER 8 MECHANICAL SERVICING

### 8.1 GENERAL

This chapter describes how to remove, replace, and adjust the field replaceable units (FRUs) in the LA210 Letterprinter.

To access an FRU, sometimes you have to remove other FRUs. Figure 8-1 is a flowchart that shows you the sequence for removing FRUs. For example, to remove the line feed motor, you must first remove the logic board, top cover, and printer mechanism.

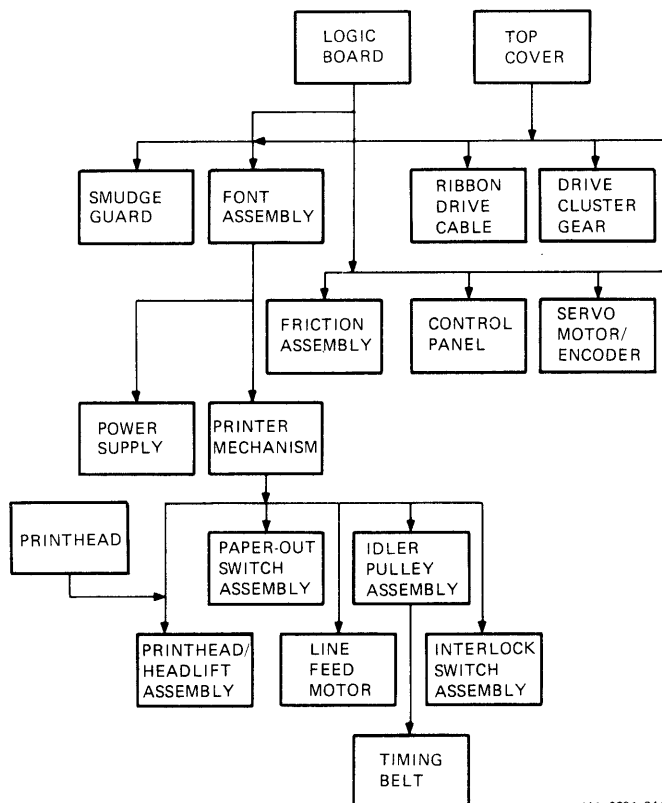

MA-0091-84A

Figure 8-1 FRU Removal Sequence

## 8.2 PRINTHEAD ASSEMBLY

Remove the printhead assembly as follows.

### WARNING

Set the power switch to 0 (off) and disconnect the ac power cord.

1. Remove the access cover by pulling it up and out.
2. Remove the ribbon cartridge.
3. Move the printhead adjustment lever to the right (Figure 8-2).

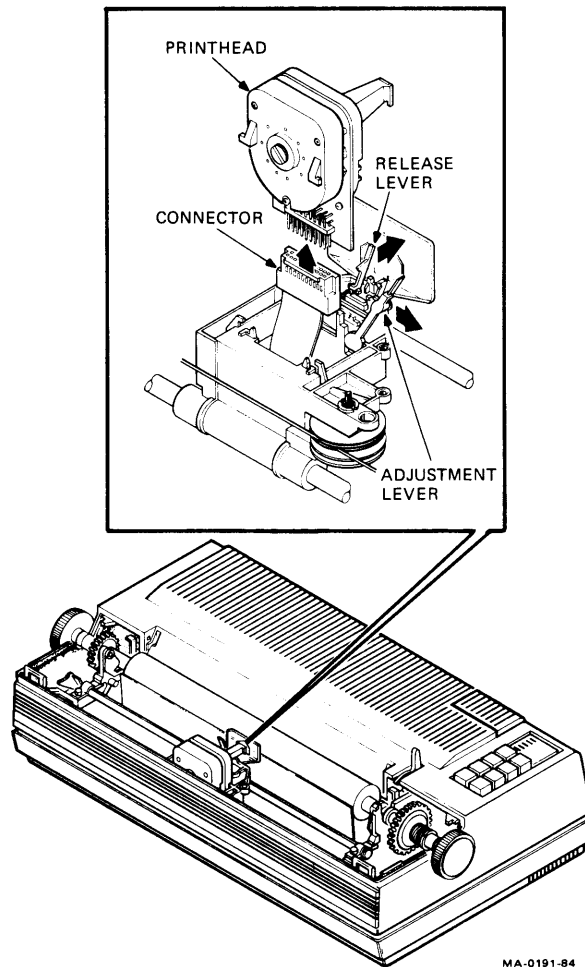

Figure 8-2 Printhead Assembly

4. Push the printhead release lever toward the back of the printer.
5. Lift the printhead up until you can grasp the printhead cable connector.
6. Disconnect the printhead from the printhead cable.
7. Remove the printhead.

To install the printhead assembly, reverse steps 1 through 7.

NOTE

When you install the printhead, make sure the pins on the printhead correctly match the holes in the printhead cable connector.

### 8.3 TOP COVER

Remove and install the top cover as follows.

WARNING

Set the power switch to 0 (off) and disconnect the ac power cord.

#### 8.3.1 Removing the Top Cover

1. Remove paper from the printer.
2. If the printer is attached to a printer stand, remove the printer from the stand.
3. Remove the tractor assembly.
4. Remove the access cover.
5. Remove the ribbon cartridge.

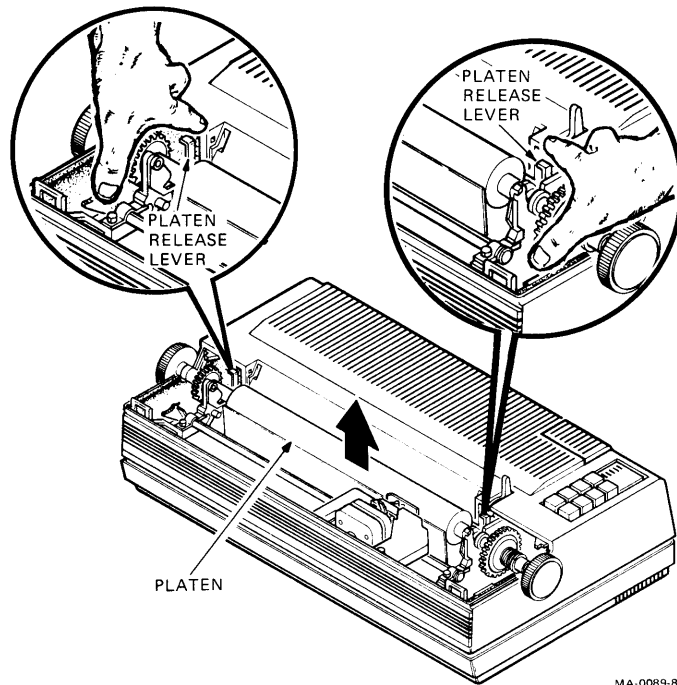

Figure 8-3 Removing the Platen

6. Remove the platen by pressing the two platen release levers at the same time (Figure 8-3). Lift the platen straight up.
7. Insert a flat blade screwdriver through the slots in the front of the bottom housing (Figure 8-4). While prying the two clips, lift the top cover. Swing the cover up and off the hinges on the rear of the printer.

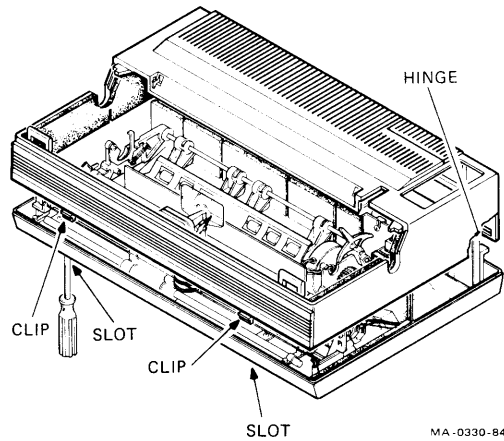

Figure 8-4 Removing the Top Cover

### 8.3.2 Installing the Top Cover

1. Line up the slots in the top cover with the hinges on the bottom housing (Figure 8-4).
2. Swing the top cover onto the hinges.
3. Press down on the front of the top cover until the clips in the top cover snap into the bottom housing.
4. Install the platen by pressing it into place. Rotate the paper adjust knob to check that the gears are properly engaged.
5. Install the ribbon cartridge.
6. Install the access cover and press it into place.
7. Install the tractor assembly.
8. If the printer stand is used, attach the printer to the stand. Load the paper.
9. Plug the ac power cord into the back of the printer. Then plug the power cord into a nonswitched, 3-prong, grounded wall receptacle.

## 8.4 LOGIC BOARD

Remove the logic board as follows.

### CAUTION

Some logic board components get very hot. Wait at least 15 minutes before you handle resistor R162 and transistors Q7 through Q24.

### WARNING

Set the power switch to 0 (off) and disconnect the ac power cord.

1. Place a cushion on the work surface.
2. Rest the back of the printer on the cushion.
3. Loosen the two outer screws holding the logic board at the back edge of the printer. Remove the other three screws (Figure 8-5).
4. Carefully pull the logic board away from the printer.

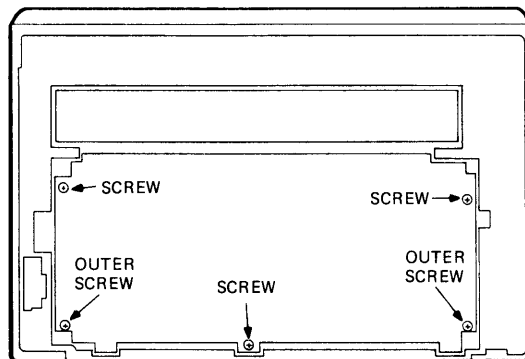

MA-0103-B4

Figure 8-5 Logic Board Screws

5. Disconnect the connectors on the logic board (Figure 8-6) and remove the board.

**NOTE**

Before you remove the faulty logic board, check that the jumper and ROM configuration, and the communication switches are set correctly.

Transfer any optional DPS ROMs from the faulty logic board to the new logic board. Cut the jumpers on the new board that were cut on the faulty logic board and set the configuration switches. (Refer to Chapter 3.)

To replace the jumpers, you must first remove the plate on the bottom of the logic board.

To install the logic board, reverse steps 3 through 5. Refer to Figure 8-6 for cable connector locations.

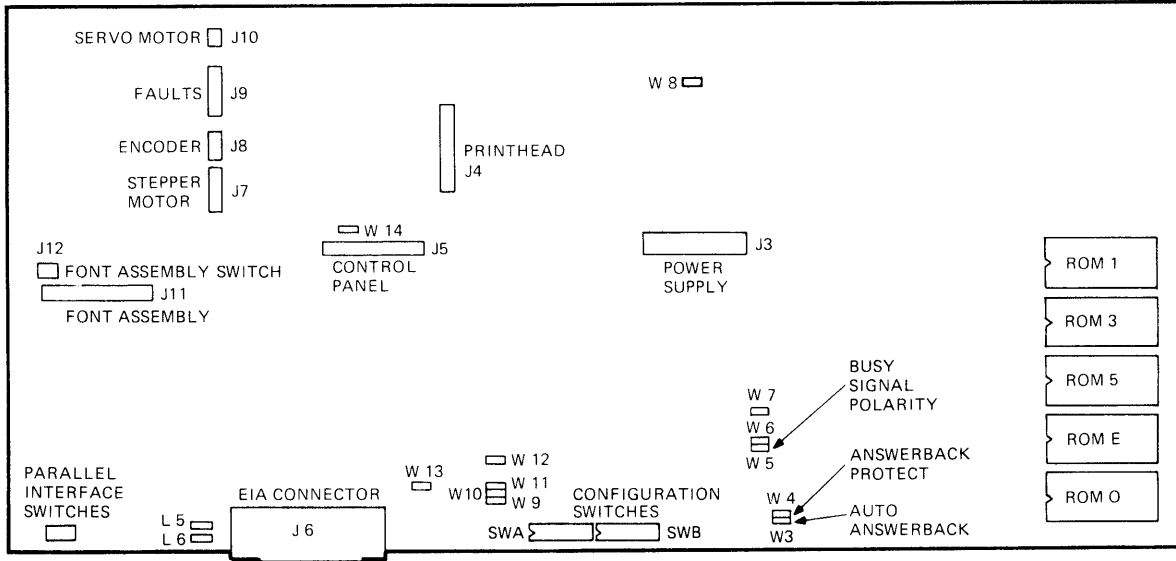

MA-0186-84

Figure 8-6 Logic Board Connector Locations

## 8.5 FONT ASSEMBLY

Remove the font assembly as follows.

### WARNING

Set the power switch to 0 (off) and disconnect the ac power cord.

First, remove the following FRUs in order.

Logic board (Paragraph 8.4)  
Top cover (Paragraph 8.3.1)

1. Loosen the three screws holding the font assembly to the printer base assembly (Figure 8-7).
2. Remove the font assembly.

To install the font assembly, reverse steps 1 and 2.

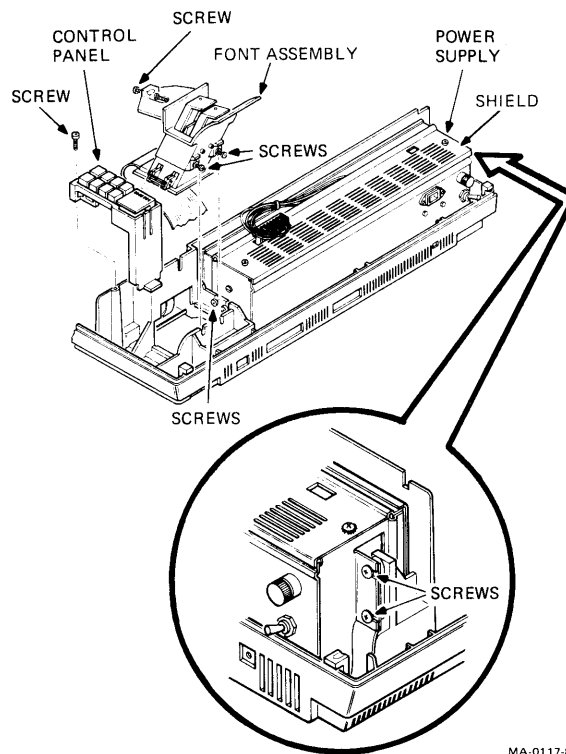

MA-0117-84

Figure 8-7 Font, Power Supply,  
and Control Panel Assemblies

## 8.6 POWER SUPPLY ASSEMBLY

Remove the power supply assembly as follows.

### WARNING

Set the power switch to  $\emptyset$  (off) and disconnect the ac power cord.

First, remove the following FRUs in order.

Top cover (Paragraph 8.3.1)  
Font assembly (Paragraph 8.5)

1. Loosen the two screws that hold the power supply to the left side plate as viewed from the rear of the printer (Figure 8-7).
2. Remove the two screws that hold the power supply to the right side plate as viewed from the rear.
3. Remove the cable from the power supply.
4. Remove the power supply and the shield.

To install the power supply, reverse steps 1 through 4. Make sure the voltage selector switch on the replacement power supply is set to the correct voltage.

## 8.7 CONTROL PANEL ASSEMBLY

Remove the control panel as follows.

### WARNING

Set the power switch to  $\emptyset$  (off) and disconnect the ac power cord.

First, remove the following FRUs in order.

Logic board (Paragraph 8.4)  
Top cover (Paragraph 8.3.1)

1. Remove the screw holding the control panel to the base assembly (Figure 8-7).
2. Remove the control panel.

To install the control panel, reverse steps 1 and 2.

## 8.8 PRINTER MECHANISM

Remove the printer mechanism as follows.

### WARNING

Set the power switch to 0 (off) and disconnect the ac power cord.

### NOTE

Be sure to reinstall the ground plane straps correctly.

First, remove the following FRUs in order.

Logic board (Paragraph 8.4)  
Top cover (Paragraph 8.3.1)  
Font assembly (Paragraph 8.5)  
Power supply (Paragraph 8.6)

1. Remove the interlock (Figure 8-16).
2. Remove the wires from the paper-out switch (Figure 8-15).
3. Remove the two clamps holding the printer mechanism (Figure 8-8).
4. Swing the mechanism up and out of the bottom housing.

To install the printer mechanism, reverse steps 1 and 3.

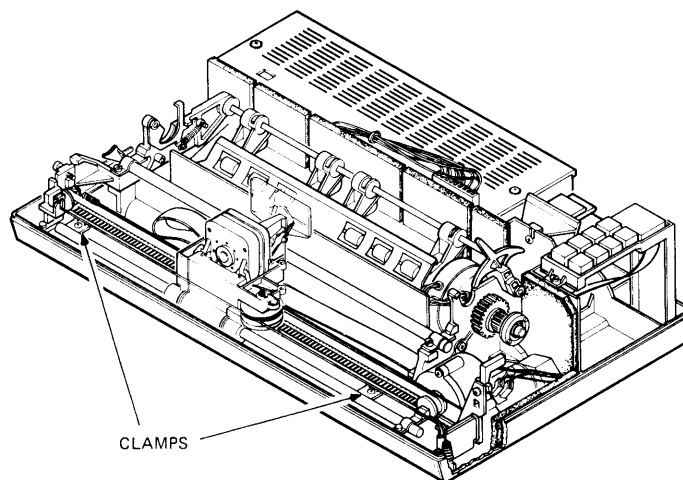

MA-0233-84A

Figure 8-8 Printer Mechanism

## 8.9 LINE FEED MOTOR ASSEMBLY

Remove the line feed motor assembly as follows.

### WARNING

Set the power switch to 0 (off) and disconnect the ac power cord.

First, remove the following FRUs in order.

Logic board (Paragraph 8.4)  
Top cover (Paragraph 8.3.1)  
Printer mechanism (Paragraph 8.8)

1. Remove the two screws holding the line feed motor to the printer mechanism (Figure 8-9).
2. Remove the ground shield.
3. Carefully feed the line feed motor cable through the printer mechanism and remove the motor assembly.

To install the line feed motor, reverse steps 1 through 3.

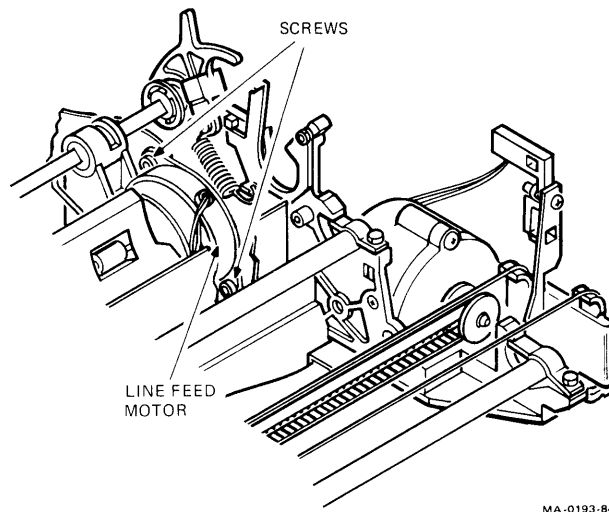

Figure 8-9 Line Feed Motor

## 8.10 SERVO MOTOR AND ENCODER ASSEMBLY

Remove the servo motor and encoder assembly as follows.

### WARNING

Set the power switch to 0 (off) and disconnect the ac power cord.

First, remove the following FRUs in order.

Logic board (Paragraph 8.4)  
Top cover (Paragraph 8.3.1)

### NOTE

Make sure to follow the original cable routing when you install a new assembly.

1. Loosen the timing belt (Figure 8-17) by turning the tensioning screw clockwise.
2. Remove the two screws holding the servo motor/encoder assembly to the printer mechanism (Figure 8-10).
3. Lift the assembly from the right side plate.

To install the servo motor encoder assembly, reverse steps 1 through 3. Readjust the timing belt (Paragraph 8.18).

## 8.11 FRICTION ASSEMBLY

Remove the friction assembly as follows.

### WARNING

Set the power switch to 0 (off) and disconnect the ac power cord.

First, remove the following FRUs in order.

Logic board (Paragraph 8.4)  
Top cover (Paragraph 8.3.1)

1. Remove the two clamps holding the printer mechanism (Figure 8-8) and pull the mechanism forward.
2. Remove the E-ring that secures the friction assembly end cap to the right side plate (Figure 8-10).

### NOTE

When you install the friction assembly, make sure the spring is properly seated in the right side plate.

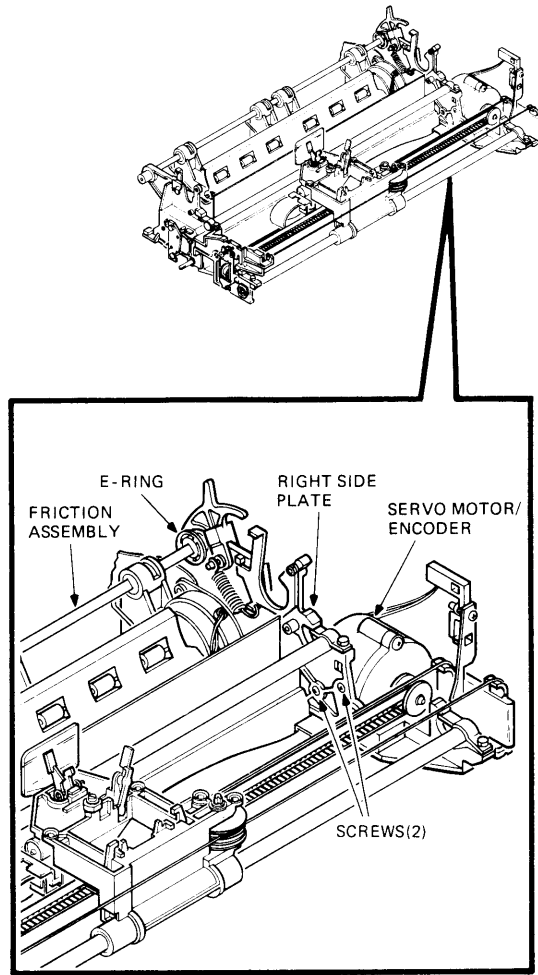

MA-0332-84

Figure 8-10 Servo Motor/Encoder  
and Friction Assembly

3. Pull the friction assembly towards the right side plate until the assembly is free from the left side plate.

To install the friction assembly, reverse steps 1 through 3.

## 8.12 DRIVE CLUSTER GEAR

Remove the drive cluster gear as follows.

### WARNING

Set the power switch to  $\emptyset$  (off) and disconnect the ac power cord.

First, remove the top cover (Paragraph 8.3.1).

1. Use the retainer clip pliers to remove the C-clip that secures the drive cluster gear to the shaft (Figure 8-11).
2. Remove the drive cluster gear.

To install the drive cluster gear, reverse steps 1 and 2.

### NOTE

Before you install the top cover, make sure the drive cluster gear can move and is not jammed.

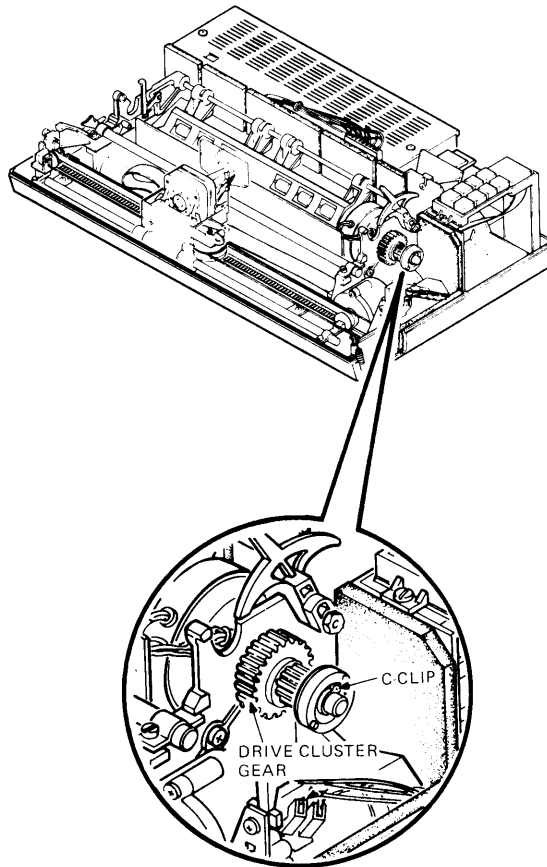

MA-0195-84

Figure 8-11 Drive Cluster Gear

## 8.13 RIBBON DRIVE CABLES

Remove the ribbon drive cables as follows.

### WARNING

Set the power switch to  $\emptyset$  (off) and disconnect the ac power cord.

First, remove the top cover (Paragraph 8.3.1).

1. Remove the two clamps holding the printer mechanism (Figure 8-7).
2. Remove the top ribbon cable by removing the cable ball from the left side plate, facing the front of the printer (Figure 8-12).
3. Remove the spring that holds the cable to the clamp.
4. Remove the ribbon drive cable.
5. Lift the printer mechanism. Remove the bottom ribbon cable by removing the cable ball from the right side plate (Figure 8-12).
6. Remove the spring that holds the cable to the clamp.
7. Remove the ribbon drive cable.

To install the ribbon drive cables, reverse steps 1 through 7.

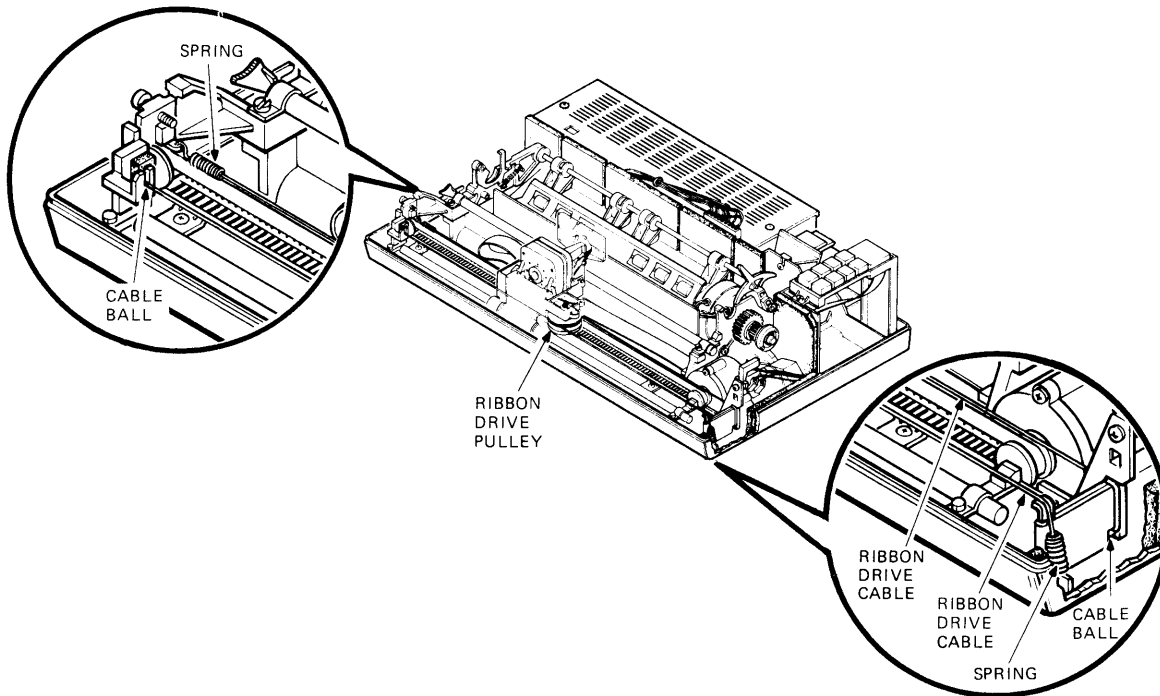

MA-0192-84

Figure 8-12 Ribbon Drive Cables

## 8.14 PRINTHEAD/HEADLIFT CABLE ASSEMBLY

Remove the printhead/headlift cable assembly as follows.

### WARNING

Set the power switch to 0 (off) and disconnect the ac power cord.

First, remove the following FRUs in order.

Top cover (Paragraph 8.3.1)  
Printhead (Paragraph 8.2)  
Printer mechanism (Paragraph 8.8)

1. Disconnect the ribbon drive cables (Figure 8-12).
2. Loosen the two rear carriage shaft screws (Figure 8-13).
3. Remove the rear carriage shaft.
4. Rotate the carriage towards the front of the printer (Figure 8-14).
5. Remove the timing belt clips (Figure 8-14) and remove the belt from the carriage.
6. Remove the nut from the printhead/headlift assembly and remove the clamp.
7. Disconnect the printhead/headlift connector (Figure 8-14).
8. Remove the printhead/headlift cable assembly from the carriage assembly.
9. Disconnect the cable from the connector on the printer mechanism (if present).

To install the printhead/headlift cable assembly, reverse steps 1 through 4.

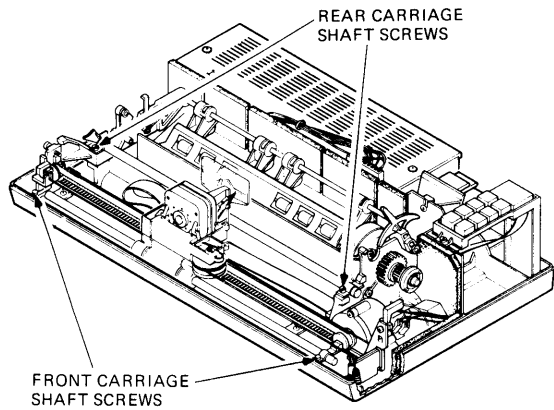

MA-0233-84B

Figure 8-13 Carriage Shaft Screws

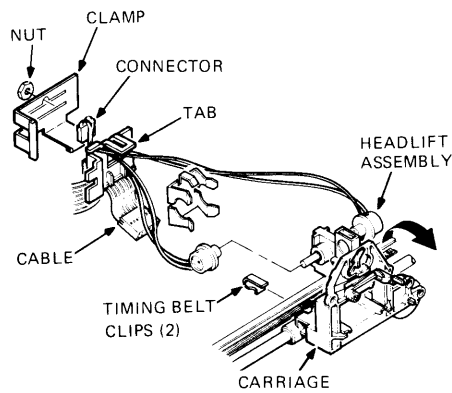
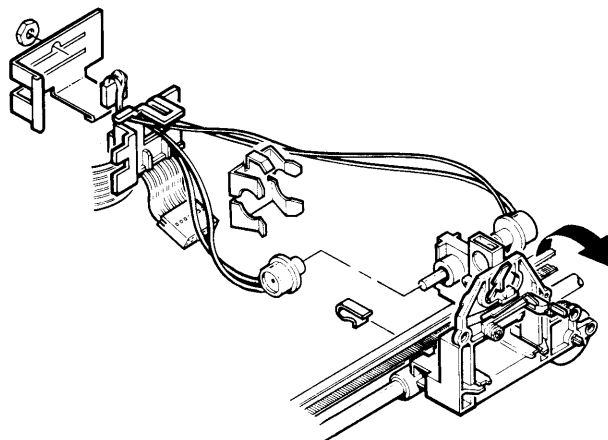

MA-0101-84

Figure 8-14 Printhead/Headlift Cable Assembly

## 8.15 PAPER-OUT SWITCH ASSEMBLY

Remove the paper-out switch as follows.

### WARNING

Set the power switch to  $\emptyset$  (off) and disconnect the ac power cord.

First, remove the following FRUs in order.

Logic board (Paragraph 8.4)  
Top cover (Paragraph 8.3.1)  
Printer mechanism (Paragraph 8.5)

1. Disconnect the paper out cables at the microswitch (Figure 8-15).

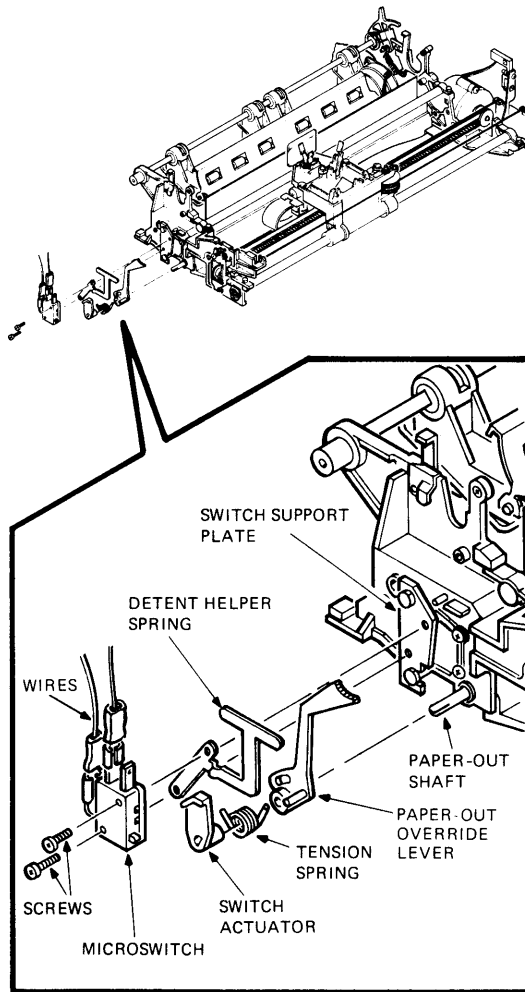

Figure 8-15 Paper-out Switch Assembly

2. Loosen the bottom screw holding the switch support plate.
3. Remove the top screw holding the switch support plate. Slide the switch support plate back off the bottom screw.

NOTE

When you install a new switch support plate, you must adjust the plate before securing it to the printer mechanism. Make sure the two screws are only finger-tight before you make this adjustment.

4. Remove the microswitch and detent helper spring from the switch support plate by removing the two screws and two kep nuts.
5. Press the ends of the tension spring slightly together, then slide the switch actuator and spring off the paper-out shaft.

NOTE

When you install a new assembly, make sure the spring is held in place between the retaining pins on the paper-out override lever and the switch actuator.

6. Remove the spring from the switch activator.
7. Slide the paper-out override lever off the paper-out shaft.

To install a new paper-out switch, reverse steps 1 through 6 and perform the following adjustment.

With the paper-out override lever in the detect position (toward the back of printer), adjust the switch support plate to activate (press) the microswitch. Then tighten the top switch support plate screw.

NOTE

The paper-out override lever must be in the detect position for the paper-out detection option to work.

## 8.16 INTERLOCK SWITCH ASSEMBLY

Remove the interlock switch assembly as follows.

### WARNING

Set the power switch to 0 (off) and disconnect the ac power cord at both ends.

First, remove the following FRUs in order.

Logic board (Paragraph 8.4)  
Top cover (Paragraph 8.3.1)  
Printer mechanism (Paragraph 8.8)

1. Remove the screw holding the cover interlock switch to the printer mechanism (Figure 8-16).
2. Remove the paper-low jack from the rear of the bottom housing.
3. Remove the interlock switch assembly.

To install the cover interlock switch, reverse steps 1 and 3. Be sure to install the paper-low jack with the detent facing down (Figure 8-16).

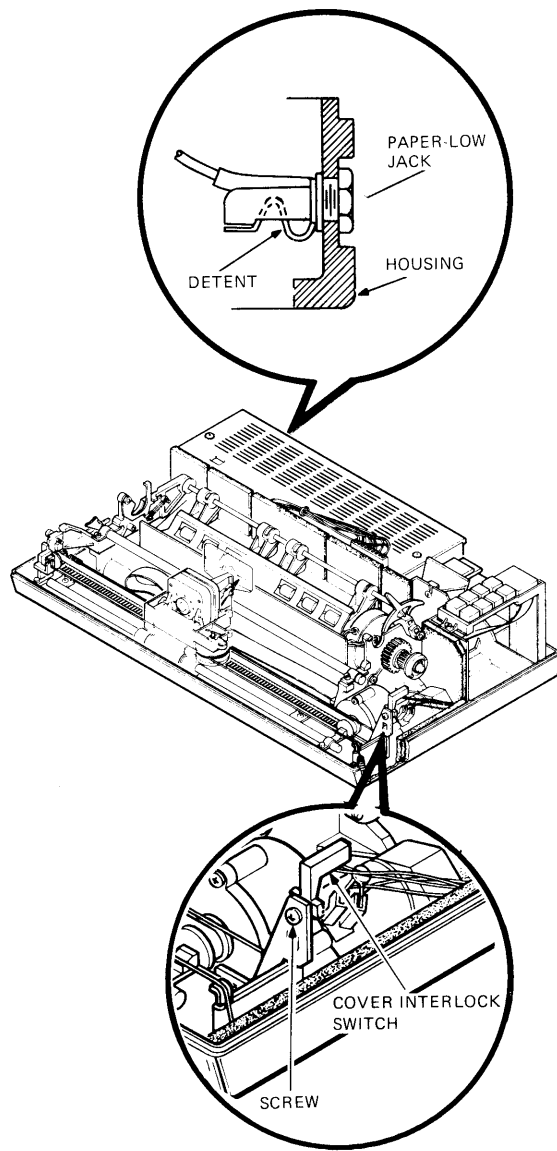

MA-0190-84

Figure 8-16 Interlock Switch Assembly

## 8.17 IDLER PULLEY ASSEMBLY

Remove the idler pulley assembly as follows.

### WARNING

Set the power switch to  $\emptyset$  (off) and disconnect the ac power cord.

First remove the following FRUs in order.

Top cover (Paragraph 8.3.1)  
Printer mechanism (Paragraph 8.5)

1. Remove the two screws holding the servo motor to provide slack to the timing belt (Figure 8-9).
2. Remove the belt tensioning screw and locking nut holding the flexure retainer (Figure 8-17).
3. Pull the retainer from the printer mechanism to remove the belt from the pulley.
4. Remove the flexure retainer.
5. Remove the pulley and tension assembly.

To install a new idler pulley assembly, reverse steps 1 through 5 and perform the adjustments as follows.

1. Disconnect the ribbon drive cable spring (Figure 8-18).
2. Position flats on the idler pulley shaft. Line them up with the flats on the flexure retainer.
3. Install the belt-tensioning screw and turn the screw until it touches the flexure retainer without changing the initial position of the tension spring.
4. Lock the setting with the lock nut.
5. Reconnect the ribbon drive cable spring.

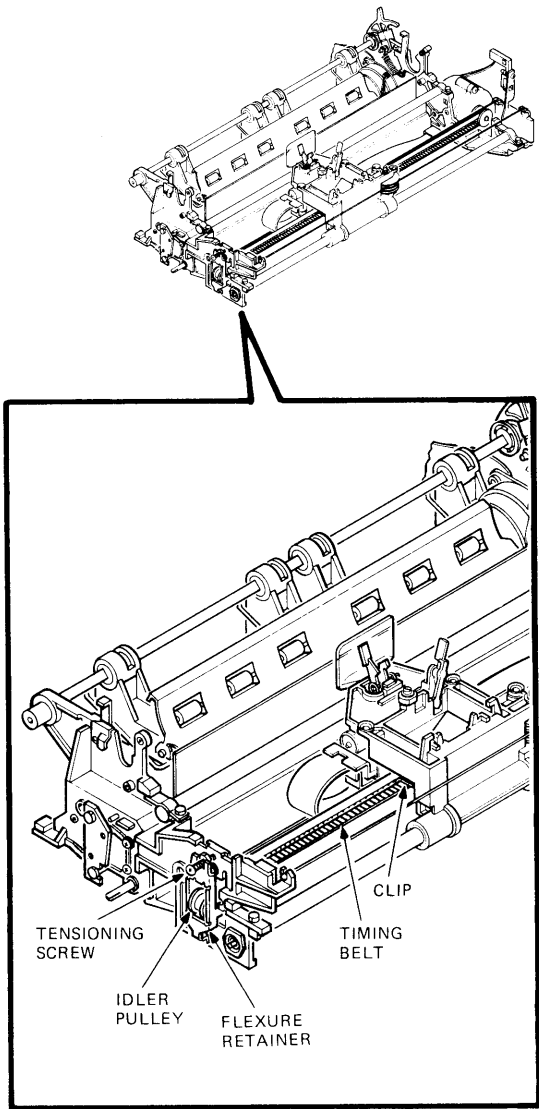
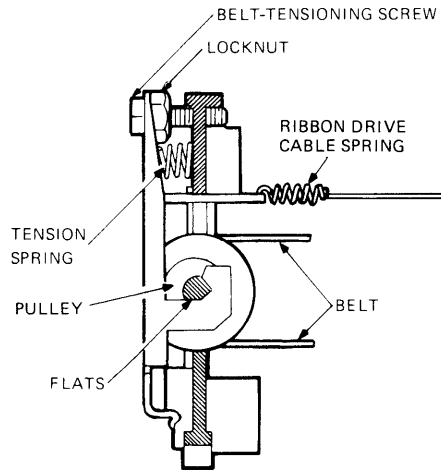

Figure 8-17 Idler Pulley Assembly

MA-0331-84



MA-1321-84

Figure 8-18 Flexure Retainer

## 8.18 TIMING BELT

Remove the timing belt (Figure 8-17) as follows.

### WARNING

Set the power switch to 0 (off) and disconnect the ac power cord.

First, remove the following FRUs in order.

Top cover (Paragraph 8.3.1)  
Printer mechanism (Paragraph 8.5)  
Idler pulley (Paragraph 8.17)

1. Remove the timing belt from the servo motor pulley (Figure 8-10).
2. Remove the two clips that hold the timing belt to the carriage assembly (Figure 8-14).
3. Slip the timing belt out of the carriage assembly and remove the timing belt.

To install a new timing belt, reverse steps 1 through 3. When you install the idler pulley, perform the following adjustments (Figure 8-18).

1. Disconnect the ribbon drive cable spring.
2. Position the flats on the idler pulley shaft to line up with the flats on the flexure retainer.
3. Tighten the belt-tensioning screw until the screw touches the flexure retainer, without changing the initial position of the tension spring.
4. Lock the setting with the lock nut.
5. Reconnect the ribbon drive cable spring.

## 8.19 CARRIAGE ASSEMBLY

The following procedure describes how to remove and install the carriage assembly.

### WARNING

Set the power switch to 0 (off) and disconnect the ac power cord.

First, remove the following FRUs in order.

Logic board (Paragraph 8.4)  
Top cover (Paragraph 8.3.1)  
Printer mechanism (Paragraph 8.5)  
Printhead (Paragraph 8.2)

1. Remove the clips that secure the timing belt to the carriage assembly (Figure 8-14).
2. Slide the timing belt from the carriage assembly.
3. Remove the ribbon drive cables (Paragraph 8.12). Slide the carriage to the left.
4. Remove the rear carriage shaft by removing the two hex screws and shaft clamps at each end of the rear carriage shaft (Figure 8-13).
5. Loosen the two hex screws at each end of the front carriage shaft.
6. Remove the front carriage shaft by sliding it out toward the left side plate.
7. Remove the carriage assembly.

To install a new carriage assembly, reverse steps 1 through 7.

### NOTE

Slide the new carriage assembly fully to the right and then to the left. If it does not slide smoothly, rotate both front and rear carriage shafts as needed.

## 8.20 Smudge Guard

Remove the smudge guard (Figure 8-19) as follows.

First, remove the top cover (Paragraph 8.3.1).

1. Swing back the friction assembly (Figure 8-19).
2. Pull the smudge guard toward the back of the printer.

To install the smudge guard, reverse steps 1 and 2, then replace the top cover.

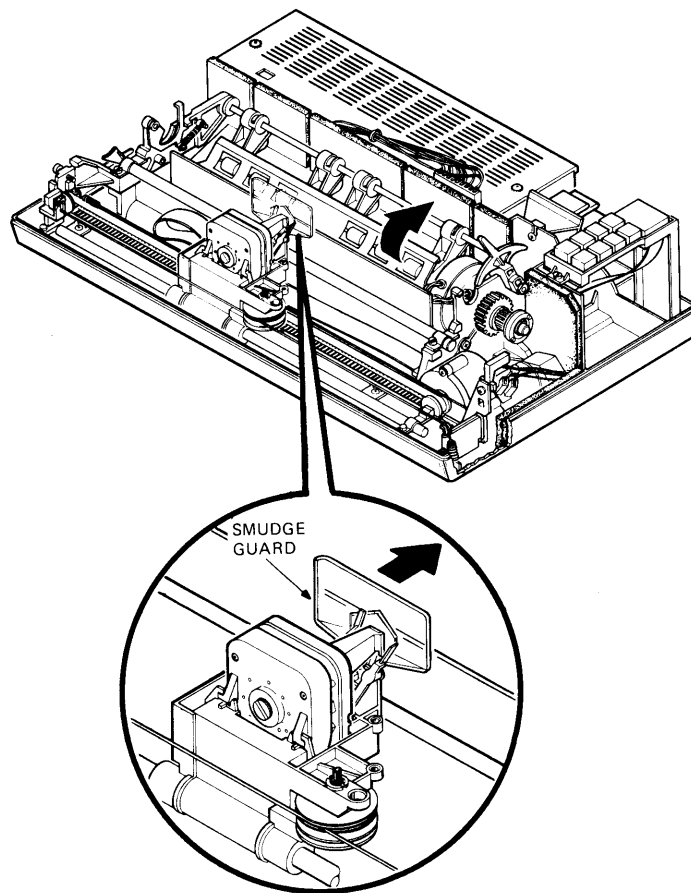

MA-0111-85

Figure 8-19 Smudge Guard

## 8.21 RECOMMENDED SPARES LIST (RSL)

Table 8-1 lists the recommended spares for the LA210 Letterprinter.

Table 8-1 Recommended Spares

Description	Part Number
Access cover (safety window assy)	70-20797-01
Base housing	74-20800-01
Carriage assembly	70-20694-01
Control panel	70-21151-01
EIA loopback connector	12-15336-01
Font assembly	70-20810-01
Friction assembly	70-15733-01
Friction feed cam	74-22987-00
Ground strap (left)	74-29690-01
Ground strap (right)	74-29691-01
Idler pulley assembly	70-15735-00
Interlock switch assembly	70-21241-01
Line feed motor	12-17474-00
Logic board	70-20689-01
Paper drive cluster gear	70-21225-01
Paper-out shaft	12-15782-00
Paper-out release lever	74-28715-00
Paper-out switch	12-16371-00
Platen	70-20684-01
Power cord (120 V)	17-00606-06
Power supply	H7844
Printer mechanism assembly	70-20693-01
Printhead	70-19655-01
Printhead adjustment lever	70-18639-00
Printhead/headlift cable assembly	70-19655-01
Printhead release lever	74-25720-00
Ribbon cartridge	36-25798-01
Ribbon drive cable	12-15348-00
Servo motor/encoder assembly	70-20681-01
Smudge guard	70-19659-01
Timing belt	12-15362-00
Timing belt spring clip	74-30386-01
Top cover	70-21249-01
Tractor assembly	70-21248-00
4 amp fuse	90-07219-02



## APPENDIX A BASE MODELS

There are three models of the LA210 Letterprinter. All models are supplied with a tractor. The International and European models are supplied with a country kit.

Model Number	Description
LA210-AA	United States model
LA210-A2	International model, operates on 120 volts
LA210-A3	European model, operates on 240 volts

The options for the LA210 Letterprinter include: fonts, the parallel interface, the bidirectional forms tractor, and the single-sheet feeder.



# APPENDIX B INTERFACES

## B.1 EIA INTERFACE

Table B-1 describes the EIA interface pin assignments. Figure B-1 shows the DB-25 (EIA RS232-C) connector at the rear of the terminal.

For special applications, you can disable the PGND (pin 1), BUSY (pin 11), SDPI (pin 12), SRTS (pin 19), and SPDS (Pin 23) signal lines by removing the corresponding jumpers. (See Paragraph 5.5.10 and Table 5-4.)

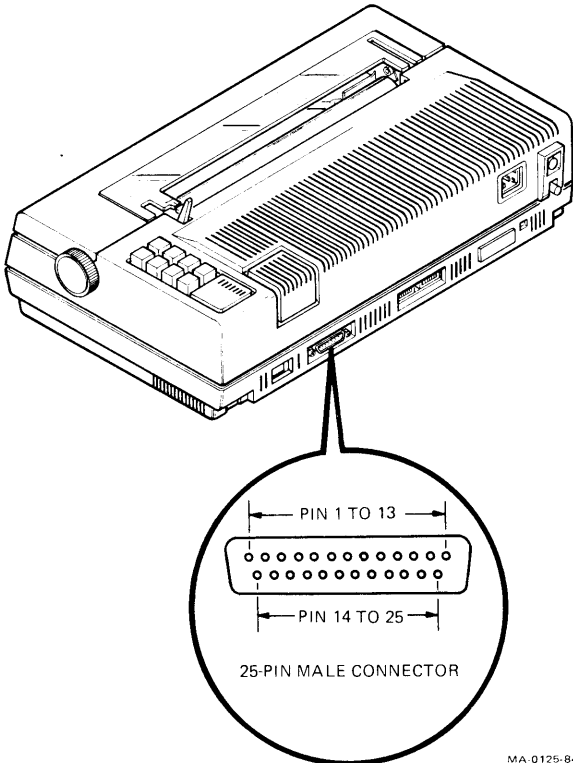

Figure B-1 DB-25 (EIA RS232-C) Connector

Table B-1 EIA Interface Pin Assignments

Pin	Name	Mnemonic	CCITT/EIA Designation	Description
1	Protective ground	PGND	101/AA	Connected to the chassis. Also connected to external ground through the third wire of the power cord.
2	Transmitted data	TXD	103/BA	Serially encoded characters generated by the printer.
3	Received data	RXD	104/BB	Serially encoded characters received by the printer.
4	Request to send	RTS	105/CA	When the RTS signal is on, the printer is ready to receive data.
5	Clear to send	CTS	106/CB	The modem sends CTS in response to RTS to indicate that it is ready to transmit data.
6	Data set ready	DSR	107/CC	DSR is on when the modem is ready. The printer does not receive data until this signal is on.
7	Signal ground	SGND	102/AB	Establishes a common ground reference potential for all interface circuits. This circuit is permanently connected to protective ground.
8	Receive line signal detect (carrier detect)	RLSD (CD)	109/CF	When RLSD is on, the modem has received the data carrier signal. The printer does not receive data until this signal is on.

Table B-1 EIA Interface Pin Assignments (Cont)

Pin	Name	Mnemonic	CCITT/EIA Designation	Description
9	Clock baud rate (switched)	RXC	--	Clock for parallel interface option.
10	No connection	--	--	--
11	Restraint signal	BUSY	--	In restraint mode, when BUSY is on, the printer requests the host to temporarily stop sending data because the input buffer is almost overflowed. In speed mode, BUSY is the same as SPDS.
12	Speed indicator	SDPI	CI	In speed mode, with SDPI on, the printer operates at 1200 baud regardless of operator selection. With SDPI off, speed mode is operator selected. In restraint mode, SPDS is the same as BUSY.
13-18	No connection	--	--	--
19	Secondary request to send	SRTS	120/SCA	In restraint mode, SRTS defines the receive ready state of the printer. SRTS functions as XON/XOFF or BUSY signals. In speed mode, SRTS is the same as SPDS.
20	Data terminal ready	DTR	108.2/CD	When the DTR signal is on, the printer can receive data.
21-22	No connection	--	--	--

**Table B-1 EIA Interface Pin Assignments (Cont)**

Pin	Name	Mnemonic	CCITT/EIA Designation	Description
23	Speed select	SPDS	111/CH	In speed mode and with the receive baud rate 1200 baud or higher, SPDS is on. In restraint mode, SPDS is the same as BUSY.
24	No connection	--	--	--
25	+5 volts (switched)	--	--	Printer supplies power to parallel interface option through this pin.

**B.2 PARALLEL INTERFACE**

When using the parallel interface option (Figure 6-7), refer to the LA10X-EP External Parallel Interface Adapter User Guide (EK-L10EP-UG) for pin assignment and signal information.

## APPENDIX C OPTIONS AND ACCESSORIES

### C.1 OPTIONS

The following options for the LA210 Letterprinter are currently available.

Part Number	Description
LA21X-BT	Bidirectional tractor
LA21X-SF	Cut sheet feeder
LA10X-AA	High resolution Courier 10 US/UK primary ROM cartridge
LA10X-AB	High resolution Courier 12 US/UK primary ROM cartridge
LA10X-AC	High resolution Gothic 12 US/UK primary ROM cartridge
LA10X-AD	High resolution Orator 10 US/UK primary ROM cartridge
LA10X-AF	High resolution Gothic 10 US/UK primary ROM cartridge
LA10X-AH	Medium resolution Courier 10 US/UK primary ROM cartridge
LA10X-AJ	Medium resolution Orator 10 US/UK primary ROM cartridge
LA10X-AP	Italics ROM cartridge
LA10X-AR	DEC Technical ROM cartridge
LA10X-AS	Optical Character Reader A 10 primary ROM cartridge
LA10X-AT	Optical Character Reader B 10 primary ROM cartridge

Part Number	Description
LA10X-AU	Olde English primary ROM cartridge
LA10X-BA	High resolution Courier 10 international overlay ROM cartridge
LA10X-BB	High resolution Courier 12 international overlay ROM cartridge
LA10X-BC	High resolution Gothic 12 international overlay ROM cartridge
LA10X-BD	High resolution Orator 10 international overlay ROM cartridge
LA10X-BF	High resolution Gothic 10 international overlay ROM cartridge
LA10X-BH	Medium resolution Courier 10 international overlay ROM cartridge
LA10X-BJ	Medium resolution Orator 10 international overlay ROM cartridge
LA10X-BN	APL 10 overlay ROM cartridge
LA10X-BV	Katakana 10 overlay ROM cartridge
LA10X-CA	High resolution Courier 10 US/UK primary ROM chip
LA10X-CB	High resolution Courier 12 US/UK primary ROM chip
LA10X-CC	High resolution Gothic 12 US/UK primary ROM chip
LA10X-CD	High resolution Orator 10 US/UK primary ROM chip
LA10X-CF	High resolution Gothic 10 US/UK primary ROM chip
LA10X-CH	Medium resolution Courier 10 US/UK primary ROM chip
LA10X-CJ	Medium resolution Orator 10 US/UK primary ROM chip
LA10X-CR	DEC Technical ROM chip
LA10X-CS	Optical Character Reader A 10 primary ROM chip
LA10X-CT	Optical Character Reader B 10 primary ROM chip
LA10X-CU	Olde English primary ROM chip
LA10X-DA	High resolution Courier 10 international overlay ROM chip

Part Number	Description
LA10X-DB	High resolution Courier 12 international overlay ROM chip
LA10X-DC	High resolution Gothic 12 international overlay ROM chip
LA10X-DD	High resolution Orator 10 international overlay ROM chip
LA10X-DE	High resolution Gothic 10 international overlay ROM chip
LA10X-DH	Medium resolution Courier 10 international overlay ROM chip
LA10X-DJ	Medium resolution Orator 10 international overlay ROM chip
LA10X-DN	APL 10 overlay ROM chip
LA10X-DV	Katakana 10 overlay ROM chip
LA10X-GA	High resolution Courier 10 LA10X-AA and LA10X-BA
LA10X-GB	High resolution Courier 12 LA10X-AB and LA10X-BB
LA10X-GC	High resolution Gothic 12 LA10X-AC and LA10X-BC
LA10X-GD	High resolution Orator 10 LA10X-AD and LA10X-BD
LA10X-GE	High resolution Gothic 10 LA10X-AE and LA10X-BE
LA10X-GH	Medium resolution Courier 10 LA10X-AH and LA10X-BH
LA10X-GJ	Medium resolution Orator 10 LA10X-AJ and LA10X-BJ
LA10X-HA	High resolution Courier 10 LA10X-CA and LA10X-DA
LA10X-HB	High resolution Courier 12 LA10X-CB and LA10X-DB
LA10X-HC	High resolution Gothic 12 LA10X-CC and LA10X-DC
LA10X-HD	High resolution Orator 10 LA10X-CD and LA10X-DD
LA10X-HE	High resolution Gothic 10 LA10X-CE and LA10X-DE
LA10X-HH	Medium resolution Courier 10 LA10X-CH and LA10X-DH
LA10X-HJ	Medium resolution Orator 10 LA10X-CJ and LA10X-DJ
LA10X-JA	Courier 10 Multinational ROM cartridge
LA10X-JB	Courier 10 Multinational ROM cartridge

Part Number	Description
LA10X-JC	Orator 10 Multinational ROM cartridge
LA10X-JD	Orator 10 Multinational ROM cartridge
LA10X-JF	Gothic 10 Multinational ROM cartridge
LA10X-JH	Courier 10 Multinational ROM cartridge
LA10X-JJ	Orator 10 Multinational ROM cartridge
LA10X-JN	VT100 10 characters/inch ROM cartridge
LA10X-JP	VT100 12 characters/inch ROM cartridge
LA10X-JR	VT100 10 characters/inch ROM cartridge
LA10X-KA	Courier 10 Multinational ROM chip
LA10X-KB	Courier 12 Multinational ROM chip
LA10X-KC	Gothic 12 Multinational ROM chip
LA10X-KD	Orator 10 Multinational ROM chip
LA10X-KF	Gothic 10 Multinational ROM chip
LA10X-KH	Courier 10 Multinational ROM chip
LA10X-KJ	Orator 10 Multinational ROM chip
LA10X-KN	VT100 10 characters/inch ROM chip
LA10X-KP	VT100 12 characters/inch ROM chip
LA10X-KR	VT100 10 characters/inch ROM chip
LA10X-LA	IBM Line Drawing ROM cartridge
LA10X-LB	MX-80 Mosaic ROM cartridge
LA10X-LC	Graftrax ROM cartridge
LA10X-LD	IBM Foreign ROM cartridge

**NOTE**

Primary font ROMs contain US and UK ASCII character sets. International overlay fonts contain ASCII German, French, Italian, Spanish, Finnish, Norwegian/Danish, Swedish, French Canadian, and VT100 line drawing character sets.

## C.2 ACCESSORIES AND SUPPLIES

The following LA210 Letterprinter accessories, supplies, components, and spares are available. Check with your sales representative or Digital's Installed Base group for the latest information.

Part Number	Description
LA10R-06	6 ribbon cartridges
DF02-AA	Direct-connect, AT&T 103J equivalent, 300 bits per second, full-duplex, asynchronous modem with EIA RS232-C interface
DF03-AA	Direct-connect, AT&T 212A equivalent, 300/1200 bits per second, full-duplex, synchronous modem with EIA RS232-C interface
BCC22A-10 (standard)	EIA RS232 female shielded null modem cable, 3 m (10 ft)
BCC22-25 (optional)	EIA RS232 female shielded null modem cable, 7.6 m (25 ft)
DF01-A	Acoustic telephone coupler, 300 baud



## APPENDIX D SPECIFICATIONS

This appendix lists the specifications for the LA210 Letterprinter.

### Physical Characteristics

#### Dimensions

Width	54.6 cm (21.5 in)
Depth	34.3 cm (13.5 in)
Height	12.7 cm (5 in) without tractor 22.8 cm (9 in) with tractor
Weight	11.3 kg (25 lb)

#### Power Supply

Model LA210A	90 to 128 Vac
Model LA210B	180 to 256 Vac

47 to 63 Hz

Power consumption	154 W
-------------------	-------

#### Temperature

Operating	10° to 40°C (50° to 104°F), noncondensing
Nonoperating	-40° to 66°C (-40° to 151°F), noncondensing

#### Relative humidity

Operating	10% to 90% with maximum
-----------	-------------------------

## Operating Characteristics

Printing technique	Impact dot matrix	
Print matrix	DEC Mode	IBM/Epson Emulation (extended height)
Draft mode	7 X 9 dots/char	9 X 12 dots/char
Letter mode (high density)	330 X 144 dots/in (33 X 18 dots/char at 10 chars/in)	33 X 24 dots/char
	(28 X 18 dots/char at 12 chars/in)	28 X 24 dots/char
Letter mode (medium density)	330 X 72 dots/in (33 X 9 dots/char at 10 chars/in)	33 X 12 dots/char
	(28 X 9 dots/char at 12 chars/in)	28 X 12 dots/char

### NOTE

In emulation mode, vertical resolution is 144 dots/inch, with an algorithm to approximate 216 dots/inch.

Graphic mode	73 X 72 dots/in 82.5 X 72 dots/in 94.29 X 72 dots/in 110 X 72 dots/in 132 X 72 dots/in 165 X 72 dots/in 220 X 72 dots/in 330 X 72 dots/in
Maximum print rate	
Draft mode (7 X 9 matrix)	240 chars/s (maximum) 185 chars/s (throughput) (10 chars/in, 132 columns)
Letter mode (33 X 18 matrix)	40 chars/s (maximum) 30 chars/s (throughput) (10 chars/in, 132 columns)
Graphic mode	7 in/s (up to 2400 dots per sec)

## Control System

Microprocessor	8085A
Control ROM	128K (16K X 8) and 64K (8K X 8)
RAM	2K (2K X 8)
Font PROMs	8K X 8
Input buffer	2K characters

## Printing Characteristics

Horizontal slew rate	45 in/s
Single line feed time	50 ms
Vertical slew rate	5 in/s
Paper feed	pin feed tractor drive, friction feed platen drive
Vertical pitch	2, 3, 4, 6, 8, or 12 lines per inch  Host-selectable
Horizontal pitch	Low resolution/draft quality, 10, 12, 13.2, or 16.5 single-width characters per inch and 5, 6, 6.6, or 8.25 double-width characters per inch  High resolution/letter quality, 10 single-width characters per inch or 5 and 6 double-width characters per inch  Host-selectable
Maximum line length (varies with horizontal pitch)	

Chars/inch	Columns
10	132
12	158
13.2	168
16.5	217
5	66
6	79
6.6	84
8.25	108

Margins	Left, right, top, bottom
	Host-selectable
Tabs	216 horizontal 168 vertical
Character sets	USASCII  VT100 Line Drawing  Digital Finnish Digital Norwegian/Danish Digital Swedish Digital French Canadian Digital Multinational Digital Symbol-10  ISO United Kingdom ISO French ISO Spanish ISO Italian ISO German Operator and host-selectable
Dot pattern sets	Courier 10, Courier 10 Multinational, VT100 line drawing set  Additional DPSS in EPROMs or ROMs and cartridges (Appendix C)
Answerback	Up to 30 characters
Positioning commands	Horizontal and vertical, absolute and relative
Feature storage	True nonvolatile memory (no batteries)
Other printer features	Cover open interlock, self-test, status message, auto and manual last character visibility

## Communication Features

Interface	EIA standard Parallel optional
Baud rates	50, 75, 110, 134.5, 150, 200, 300, 600, 1200, 1800, 2400, 4800, 7200, and 9600 baud
Split baud rates	Send / Receive 75        600 75        1200 150       600 150       1200 300       2400 300       4800 600       2400 600       4800
Character format	7- or 8-bit ASCII, serial, asynchronous
Parity	Even/odd, mark/space. Eighth, ninth or tenth bit set to mark or space
Input buffer	2K characters standard
Modem control	Full-duplex with or without EIA control (switch selectable)

## Ribbon Specifications

### Cartridge dimensions

Length	10.64 cm (4.188 in)
Width	14.15 cm (5.570 in)
Height	1.42 cm X 0.051 cm (0.560 in X 0.02 in)

### Ribbon fabric

Material	Nylon, nontextured
Thickness	0.086 mm X 0.1076 mm (0.0034 in X 0.0042 in)
Width	1.27 cm X 0.0381 cm (0.5 in X 0.15 in)

Ribbon life	From 3.5M to 10M characters in continuous printing
-------------	---

## Paper Specifications

Width	7.62 cm to 37.78 cm (3 in to 14.87 in)
Weight (single-part)	6.8 kg (15 lb) paper min 0.25 mm (0.010 in) card stock max
Weight (multipart)	1 to 4 parts (see note)
Thickness	0.50 mm (0.020 in) max

### NOTE

Multipart forms may have only one card. The card must be on the back. First-surface impact paper is not recommended. Dot or line glue margins are acceptable (if line is on one margin only). Split forms (forms with a different number of sheets on each side) are not recommended. Single-part paper may be used with the cut-sheet feeder option. Stapled forms are not recommended.

# INDEX

## A

### Address

- bus, 5-4
- map, 5-4
- ANSI, 1-1
- Answerback, 1-3, 3-19, 5-22, 5-27
- ASCII, 1-3, 5-9
- Asynchronous, 5-1, 5-9
- Audible indicator, 3-9

## B

### Base models (see Appendix A)

- Baud Rate, 1-3
  - clocks, 5-14, 5-15
  - switches, 3-13, 5-11

### Bell

- Test, 7-22
- tone, 3-11
- Bolding, 3-17, 5-41
- Break, 5-18
- Busy, 3-19, 5-19, 5-20, 5-27

## C

### Cable bus buffer, 5-43

### Cabling, 2-4

### Carriage

- assembly, 8-25
- motion failure, 7-9
- speed, 5-34

### Carrier detect, 5-16

### Character

- pattern test, 3-20
- printing, 5-36
- processing, 5-22
- sets, 4-1
- style (see FONT)

- Clear to send, 5-16
- Communication
  - failures, 7-7, 7-16
  - firmware, 5-24
  - and I/O data processing, 5-9
  - interface, 5-16
  - modes, 5-17
- Configuration switches, 3-11
- Control
  - bus, 1-2
  - character (see MODES 0, 1, 2, 3)
  - lines, 5-22, 7-4
  - logic, 1-3, 5-1
  - sequences (see MODES 0, 1, 2, 3)
  - system, 1-2, 5-3
- Control Panel, 3-1, 3-5
  - assembly, 8-1
  - indicators, 3-8, 3-9
- Correspondence quality, 5-30, 5-31
- Cover interlock switch, 7-7

## D

- Data
  - bus, 5-4
  - format, 5-11
  - handling through USART, 5-13
  - path, 7-4
  - terminal ready, 5-4, 5-16
  - transfer control modes, 5-19
  - set ready, 3-8, 5-16, 5-18
- DC Servo Encoder Test, 7-22
- DC035, 5-31 (see PRINTER CONTROLLER)
- DEC mode, 4-1 to 4-22 (see MODE 0)
- Disconnect, 5-18
- Dot
  - data interrupt (RST5), 5-36
  - FIFOs, 5-36
  - matrix, 1-3, 2-5, 3-10, 5-29
  - pattern set (DPS), 1-3, 3-20, 5-28, 6-7
- Double-height printing, 5-38, 5-41
- Draft mode, 5-20, 5-30
- Drive cluster gear, 5-43, 8-14

## E

- EIA
  - communication, 5-16
  - interface (see Appendix B)
  - jumpers, 5-26
- Eight-bit character equivalents, 4-8
- Eight-bit character sets, 4-1
- Electrically alterable read-only memory (EAROM), 1-2, 5-22

Emulation, 3-10, 3-14, 5-38 (see MODES 1, 2, 3)  
End of transmission, 5-18  
Escape and control sequences  
    (see MODES 0, 1, 2, 3)

## F

Factory settings, 3-10  
Failures, (see TROUBLESHOOTING), 3-23, 7-1  
Feedback pulses, 1-3  
Fill time characters, 5-20, 5-21  
Firmware, 5-24, 5-3  
Flat descenders, 7-12  
FONT  
    assembly, 5-43, 8-8  
    cartridge, 3-20, 6-1  
    checkout, 6-3, 6-11  
    indicators, 3-7  
    ROM options (see Appendix C)  
    ROM chips, 6-1, 6-7  
Form handling and line feed routines  
    in IBM/Epson emulation modes, 5-41  
Frequency dividers, 5-14  
Friction assembly, 5-43, 8-12  
FRU (see MECHANICAL SERVICING)  
Functional  
    jumpers, 5-26  
    overview, 5-3  
    tests, 7-17  
Full Duplex, 5-16 to 5-18

## G

Graphic(s), 1-1, 3-16, 3-19, 3-21,  
    4-32, 5-31, 5-34,

## H

Hardware interrupts, 5-6  
H7844 (see POWER)  
Headlift, 5-37, 5-38, 5-40  
Head drivers, 5-36  
High resolution, 5-30, 5-38 (see LETTER QUALITY)  
Horizontal pitch, 5-31  
Horizontal registration, 3-20

## I

IBM/Epson MX80, 3-14, 4-21 (see MODE 1)  
IBM/Epson MX80 plus Graftrax, 3-16, 4-28  
(see MODE 2)  
IBM graphics printer, 3-17, 4-40  
(see MODE 3)  
Idler pulley assembly, 8-22  
Idling state, 5-9  
Indicators, 3-1  
Input buffer, 5-17, 5-18, 5-20  
Input queue, 5-22  
Installation, 2-1  
Interface (see Appendix B)  
Interlock switch assembly, 8-20  
Internal data manipulation, 5-22  
Interrupt, 5-7, 5-11, 5-43  
vectors, 5-6  
I/O  
data processing, 5-9  
/not memory signal, 5-4  
read, 5-4  
write, 5-4

## J

Jumper-selectable features, 3-19

## L

Letter Quality, 5-30, 5-31, 5-37  
Line feed, 5-41  
motor control byte, 5-41  
motor driver, 5-42  
motor assembly, 8-11  
test, 7-29  
Line printing, 5-37  
Line terminator, 5-38  
Loading paper, 2-9  
Logic board, 3-11, 5-1, 5-46, 7-22, 8-6  
Loopback self-test, 3-22, 7-4, 7-7  
Low resolution, 5-30 (see DRAFT MODE)

## M

Margins, 3-2, 5-34  
Mark state, 5-9  
Maximum interrupt rate, 5-11  
Mechanical servicing, 8-1  
Microcode, 3-23, 5-37  
Microprocessor, 5-1, 5-4 to 5-14, 5-31,  
5-41 to 5-43  
Minus signal, 5-34

- Mode 0 (DEC Mode), 4-1
  - standard C0 and C1 control characters, 4-1
  - graphics mode control characters
  - escape and control sequences, 4-8
  - switch settings, 3-11
- Mode 1, 4-21
  - C0 and C1 control characters, 4-24
  - IBM/Epson form handling and line feed routines, 5-41
  - IBM/Epson printing process, 5-38
  - escape and control sequences, 4-25
  - switch settings, 3-4
- Mode 2, 4-28
  - C0 and C1 control characters, 4-30
  - escape and control sequences, 4-34
  - restoring mode 2 switch settings, 4-30
  - switch settings, 3-16
- Mode 3, 4-40
  - C0 and C1 control characters, 4-46
  - escape and control sequences, 4-49
  - switch settings, 3-17
- Modem, 5-16, 5-19
- Modes of operation, 5-17
- Monitor, 5-7

## N

- Nonprinting self-test, 3-20, 3-22
- Nonvolatile memory, 5-22

## O

- On-line, 5-17
- Off-line, 5-17
- Operator
  - information, 3-1
  - selectable features, 3-1, 3-10
  - tests, 3-19
  - troubleshooting, 3-23
- Options and accessories (see Appendix C)
- Optional correspondence quality, 5-30
- Output buffer, 5-13
- Overlay, 6-1, 6-7
- Overrun error, 5-13
- Overstrike alignment, 3-20

## P

Parser, 5-22

### Paper

- advancing, 5-41
- drive cluster gear, 5-43
- feed mechanism, 1-3
- feed subsystem, 5-41
- loading, 2-9
- out condition, 5-9, 5-18
- out switch, 2-9, 2-12, 2-14, 8-18
- types of, 2-9

Parallel interface (LA10X-EP)  
3-10, 6-12, (see Appendix B)

Parity, 5-11

Pitch, 5-29

Platen assembly, 5-43

Plus signal, 5-34

POS signal, 5-37

### Position

- encoder, 5-34
- register, 5-35

Power, 5-47

- assembly, 8-9
- functional description, 5-46
- requirements, 2-1
- voltage test points, 7-19

### Power-up

- checksum test, 2-5, 6-3
- failures, 7-6
- self-test, 3-19

### Print

- process routines in IBM/Epson emulation mode, 5-38
- quality failures, 7-13
- speed, 5-30
- wire, 5-38 to 5-40

### Printer

- character test, 7-27
- controller (DC305), 1-1, 5-1, 5-14, 5-31, 5-33, 5-43
- controls, 3-1
- mechanism, 5-3, 8-10
- self-test, 3-20

### Printing

- format, 5-29
- overview, 5-28
- process, 5-28, 1-3
- self-tests, 3-20

## Printhead

- actuator linkage, 5-37
- adjustment, 2-14
- assembly, 8-1, 8-17
- lift function, 5-37
- matrix, 5-30
- positioning process, 5-28
- position tracking, 5-31
- solenoid control, 5-31
- servo motor control, 5-31

Printwire, 5-38 to 5-40

## Q

Queues, 5-22

## R

RAM, 1-2, 5-1, 5-4

- output buffer, 5-13

Ready flag, 5-16

Receive, 5-13

- data line signal
- detect, 5-16, 5-18

Restraint mode, 5-19

Request to send, 5-18

- return 5-34, 7-26

RESET IN signal, 5-4

Ribbon

- cartridge, 2-6
- drive cables, 8-15

ROM, 1-2, 5-1 (see FONT)

- EAROM, 5-22
- identification codes, 6-6
- microswitch, 5-6
- options, 6-1 (see Appendix C)

RS232-C, 1-1, 5-16, 3-11

RST5 (dot data interrupt), 5-36

RST6.5 interrupt, 5-6, 5-24

RUN signal, 5-42

## S

Secondary request to send, 5-16

Self-tests, 3-1, 7-1

Self-test mode, 5-18

Serial

- character, (see SEVEN-BIT and EIGHT-BIT)
- bit rate, 5-14
- data, 5-9

Servo motor, 1-5, 5-34, 5-35

Servo head positioning, 5-33

Servo motor encoder assembly, 8-13

Servo speed, 5-31  
Seven-bit, 1-1, 4-1  
Site considerations, 2-1  
Solenoid, 1-3, 5-28, 5-31, 5-33, 5-35  
Space, 5-18, 5-34  
Spares list, 8-27  
Split baud rates, 5-14  
Specifications (see Appendix D)  
Speed  
    control mode, 5-19  
    indicator, 5-16, 5-19  
    select, 5-16, 5-19  
Stepper motor, 1-3, 5-41, 5-43  
Start bit, 5-9  
Status message, 3-11, 3-20, 6-3,  
Stop bit, 5-9  
Subscript, 1-3, 3-17, 5-40, 5-43  
Sub character, 5-20  
Superscript, 1-3, 3-17, 5-41, 5-43  
System  
    clocks, 7-20  
    timing, 5-6

#### T

Theory of operation, 5-1  
Timeout message, 5-21  
Timing belt, 1-3, 8-24  
Tractor, 2-8, 5-43  
Transmit, 5-13  
Top cover, 8-3  
Troubleshooting, 3-23, 7-1

#### U

Underlining, 3-17  
USART, 1-3, 5-1, 5-9, 5-11, 5-13,  
    5-14, 5-22, 7-31

#### V

Visual indicators, 3-8  
Voltage (see POWER)

#### W

Wait State, 5-6  
Wake-Up Signal, 5-4  
Wake-Up test, 7-19

#### X

XON/XOFF, 5-17, 5-19 to 5-21