

CHAPTER 6

LA120 SUBASSEMBLY REMOVAL AND INSTALLATION

6.1 GENERAL

This chapter contains information pertaining to the removal and replacement of the mechanical and electrical subassemblies of the LA120.

Figure 6-1 lists all of the removal procedures in this chapter and the sequence in which these procedures are performed. As an example, Figure 6-1 illustrates that to remove the power entry bracket assembly, the power supply assembly removal procedure must be performed first.

DIGITAL Field Service recommends that the following LA120 assemblies be replaced in their entirety in a field environment.

- Print head assembly (Paragraph 6.3)
- Print head cable (Paragraph 6.4)
- Timing belt (Paragraph 6.5)
- Carriage assembly (Paragraph 6.7)
- Ribbon drive pulley (Paragraph 6.10)
- Ribbon drive assembly (Paragraph 6.11)
- DC motor and encoder assembly (Paragraph 6.14)
- Tractor drive shafts and tractor assemblies (Paragraph 6.15)
- Idler gear assembly (Paragraph 6.16)
- Stepping motor assembly (Paragraph 6.17)
- Ribbon chassis assembly (Paragraph 6.18)
- Keyboard/numeric pad assembly (Paragraph 6.20)
- Power supply assembly (Paragraph 6.21)
- Printer mechanism assembly (Paragraph 6.22)
- CVT power supply module (Paragraph 6.23)
- Power entry bracket assembly (Paragraph 6.24)
- Fan (Paragraph 6.25)
- Logic/power board (Paragraph 6.26)

6.2 PRINTER HOUSING

The following procedure describes the removal and installation of the printer housing.

6.2.1 Printer Housing Removal

1. Remove power from printer by disconnecting ac plug.
2. Remove printer paper and printer cover.
3. Remove six (6-32) self-tapping screws and flat washers that secure printer housing to cabinet base (Figure 6-2) and set them aside.

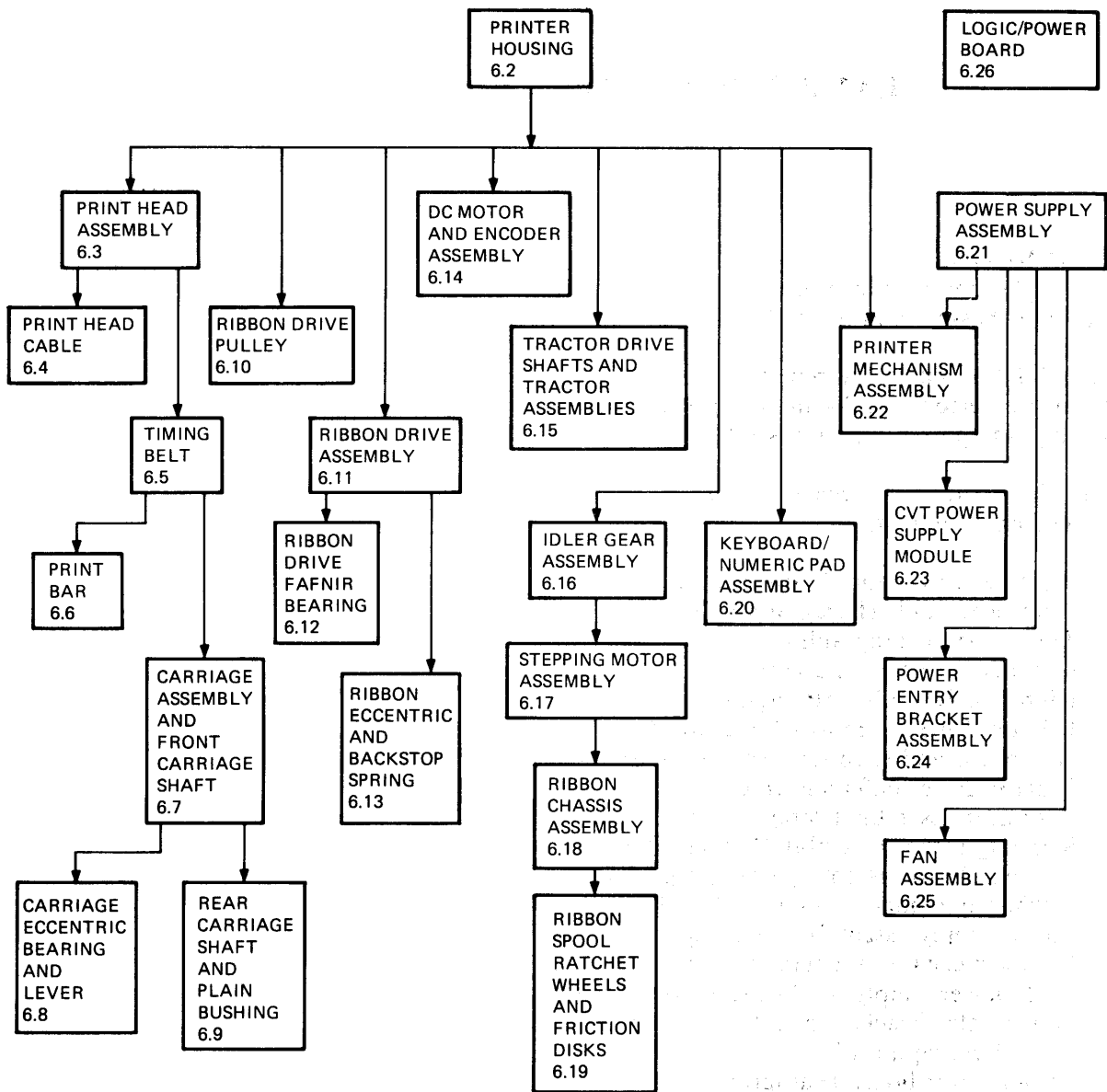

MA-2566A

Figure 6-1 Assembly Removal Sequence

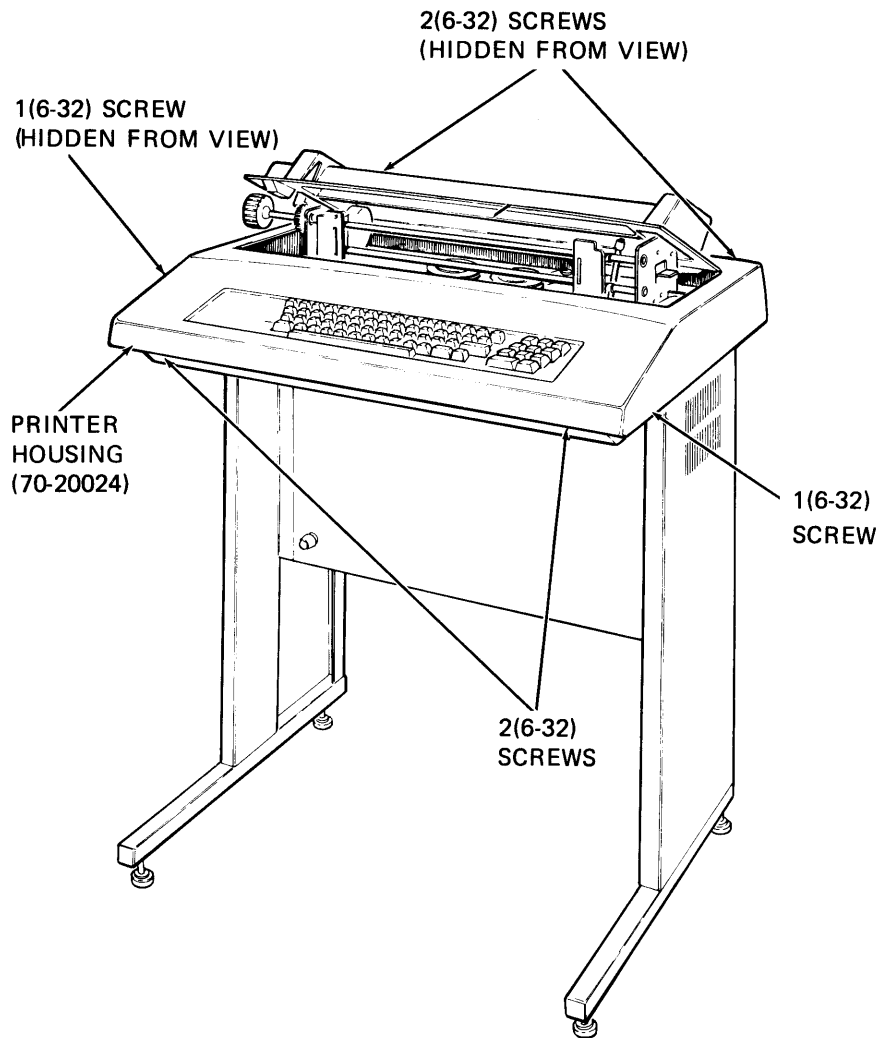

MA-2567

Figure 6-2 Printer Housing Removal and Installation

6.2.2 Printer Housing Installation

1. Place printer housing on cabinet base and secure it with six (6-32) self-tapping screws and flat washers.
2. Install printer paper and cover.
3. Restore power.

6.3 PRINT HEAD ASSEMBLY

The following procedure describes the removal and installation of the print head assembly. Refer to Figure 6-3 during the procedure.

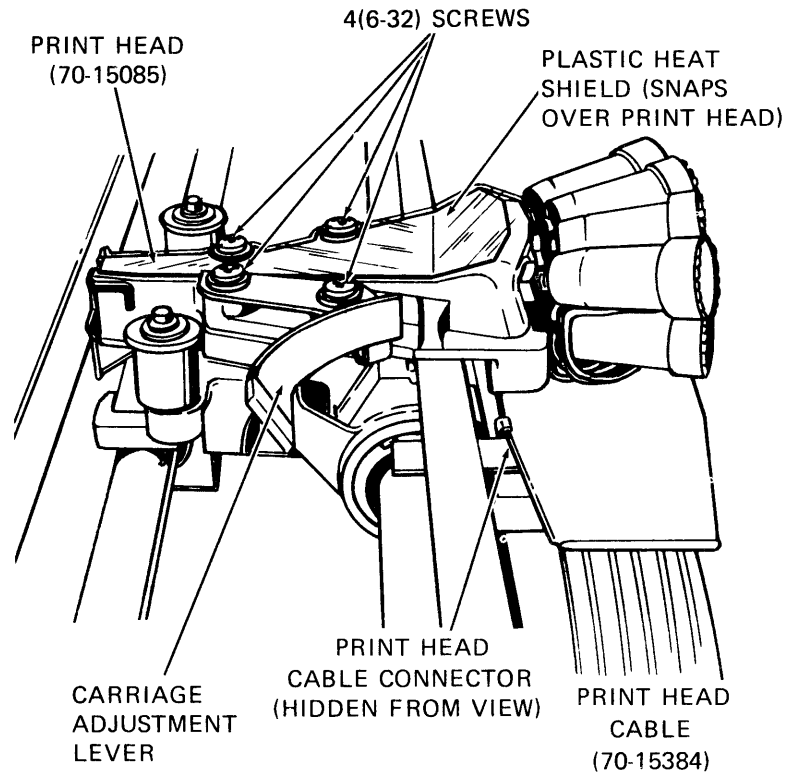

MA-2568

Figure 6-3 Print Head Removal and Installation

6.3.1 Print Head Assembly Removal

1. Perform printer housing removal procedure (Paragraph 6.2.1).
2. Remove ribbon.
3. Snap off print head heat shield.
4. Move carriage adjustment lever to the highest number (toward operator).
5. Remove the four (6-32) screws and washers that secure print head to carriage.
6. Disconnect print head cable connector from print head; then remove print head.

6.3.2 Print Head Assembly Installation

1. Connect print head cable to new print head.

CAUTION

When installing print head, check to ensure that timing belt teeth mesh (seat) with slots in the carriage.

2. Secure new print head with four (6-32) screws and washers. Make screws finger tight.
3. Move print head to the middle of print bar.
4. Set carriage adjustment lever to No. 1.

5. Manually push print head forward until it touches print bar.
6. Check to ensure that timing belt is aligned with pulley.
7. Tighten four (6-32) screws (10 ± 2 in/lb of torque).

CAUTION

Do not over-tighten the print head.

8. Install print head heat shield.
9. Replace ribbon.
10. Slide carriage along carriage shaft to ensure that nothing is binding and that timing belt is aligned with pulleys.
11. Perform printer housing installation (Paragraph 6.2.2).

6.4 PRINT HEAD CABLE

The following procedure describes the removal and installation of the print head cable.

6.4.1 Print Head Cable Removal

1. Perform printer housing removal procedure (Paragraph 6.2.1).
2. Perform print head assembly removal procedure (Paragraph 6.3.1).

CAUTION

Removing and installing the print head cable, without removing print head, can damage print head connector.

3. Disconnect cable from J6 (Figure 5-1) on logic/power board and remove it from cable clamps.

6.4.2 Print Head Cable Installation

1. Install one end of cable as shown in Figure 6-4.
2. Dress the other end of cable down through slot in rear of cabinet, and connect cable connector to J6 on logic/power board.
3. Perform print head assembly installation procedure (Paragraph 6.3.2).
4. Perform printer housing installation procedure (Paragraph 6.2.2).

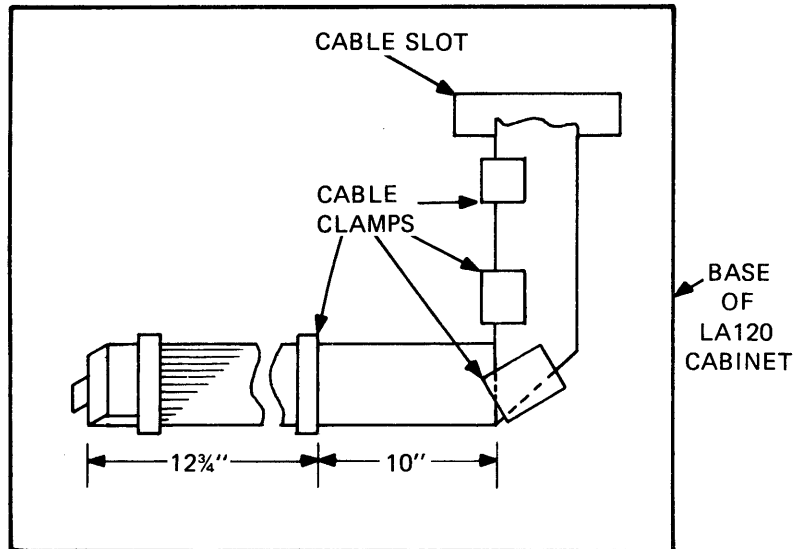

MA-2571

Figure 6-4 Print Head Cable

6.5 TIMING BELT

The following procedure describes the removal and installation of the timing belt.

6.5.1 Timing Belt Removal

1. Perform printer housing removal procedure (Paragraph 6.2.1).

NOTE

The print head ribbon cable does not have to be disconnected when performing the following procedure.

2. Perform print head assembly removal procedure (Paragraph 6.3.1).
3. Push carriage assembly to extreme left, and slip timing belt off dc motor pulley.

6.5.2 Timing Belt Installation

1. With belt tension spring in place (Figures 6-5 and 6-6), press left-hand pulley against printer mechanism and slip on the new timing belt.
2. Rotate timing belt screw (Figure 6-5) until it just touches ribbon drive assembly. Screws should not exert pressure on ribbon drive assembly.
3. Perform print head assembly installation procedure (Paragraph 6.3.2).
4. Perform printer housing installation procedure (Paragraph 6.2.2).

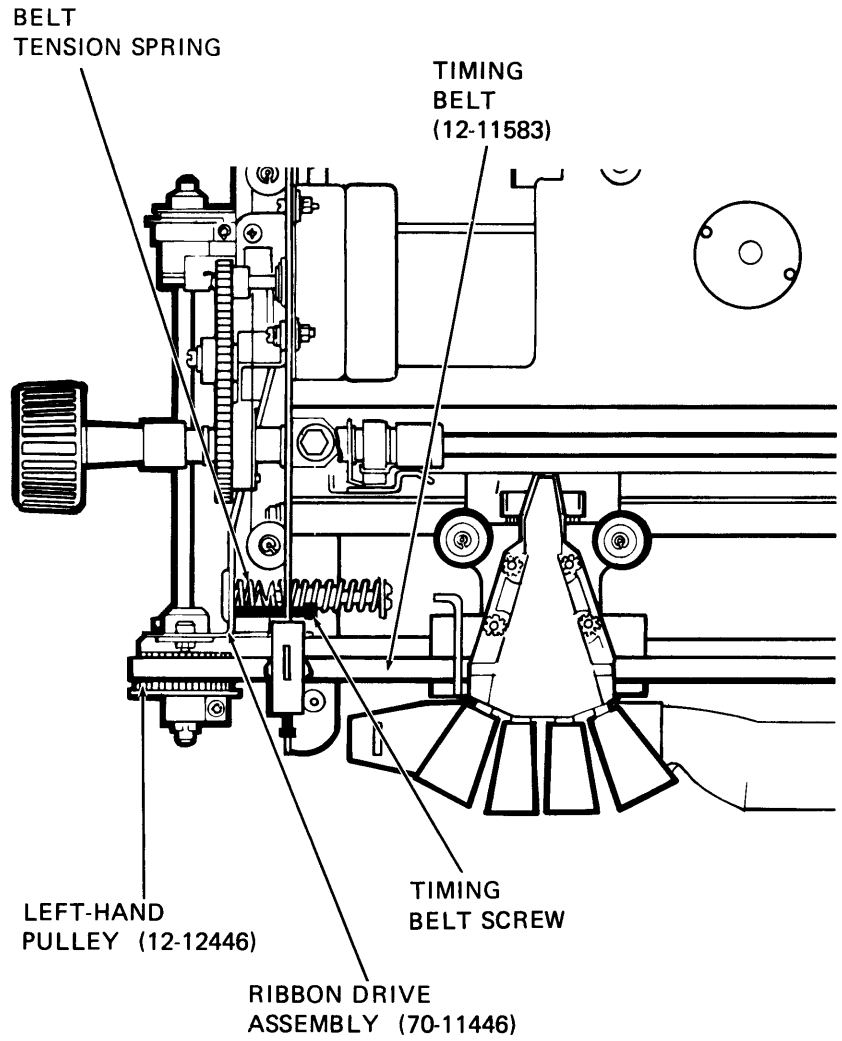

MA-2569

Figure 6-5 Belt Tension Spring Location

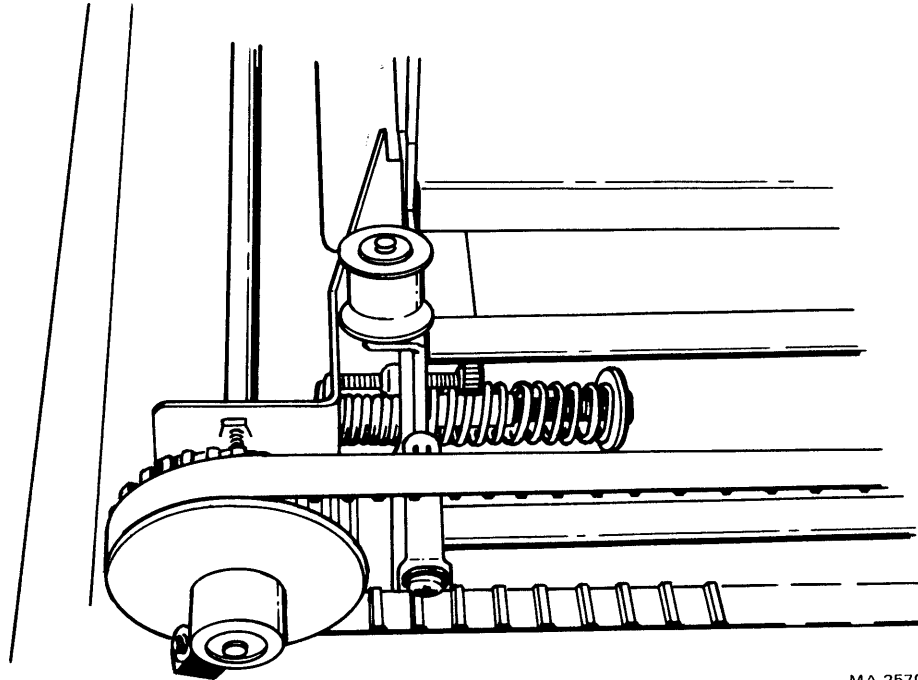

MA-2570

Figure 6-6 Belt Tension Spring (Detailed View)

6.6 PRINT BAR

6.6.1 Print Bar Removal

1. Perform timing belt removal procedure (Paragraph 6.5.1).
2. Move right-hand and left-hand tractors to their rightmost position.
3. Remove two 3/8 inch hex-head screws from the ends of the print bar (Figure 6-7a).
4. Remove print bar by carefully lifting left end of bar and moving it forward and toward the left. Ensure that bar does not hit ribbon idlers on carriage assembly or lower edge of tractors.

6.6.2 Print Bar Installation

1. Move the right-hand and left-hand tractors to their rightmost position.
2. Install print bar, right end first, being careful not to hit ribbon idlers on carriage assembly or lower edge of tractors.
3. Install two 3/8 inch hex-head screws into the ends of the print bar.
4. Perform print bar adjustment procedure (Paragraph 7.9).
5. Perform timing belt installation procedure (Paragraph 6.5.2).

6.7 CARRIAGE ASSEMBLY AND FRONT CARRIAGE SHAFT

The following procedure describes the removal and installation of the carriage assembly and front carriage shaft.

6.7.1 Carriage Assembly and Front Carriage Shaft Removal

1. Remove power by unplugging LA120 power cord.
2. Perform printer housing removal procedure (Paragraph 6.2.1).
3. Unsnap keyboard bezel to enable easy access to carriage shaft clamp screws (Figure 6-7a).
4. Perform print head removal procedure (Paragraph 6.3.1).
5. Perform timing belt removal procedure (Paragraph 6.5.1).
6. Loosen two (8-32) front carriage clamp screws (Figure 6-7a).
7. Using a screwdriver, pry the top of the right carriage shaft clamp up and to the right as shown in Figure 6-7b.

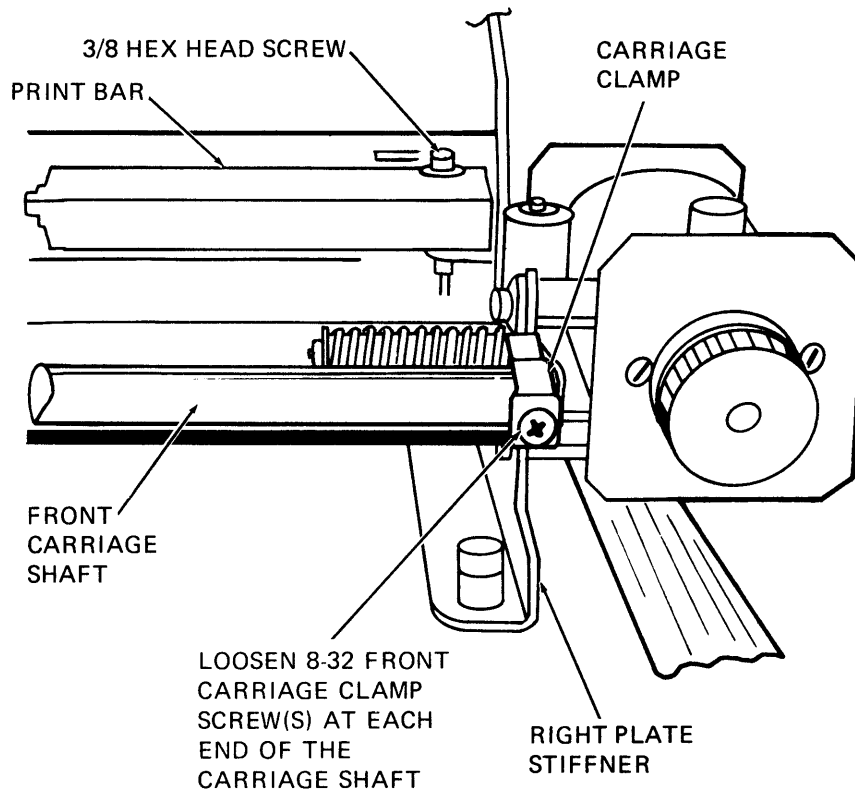

a. Carriage Shaft Clamp Screws

MA-2590A

Figure 6-7 Carriage Assembly and Front Carriage Shaft Removal and Installation (Sheet 1 of 2)

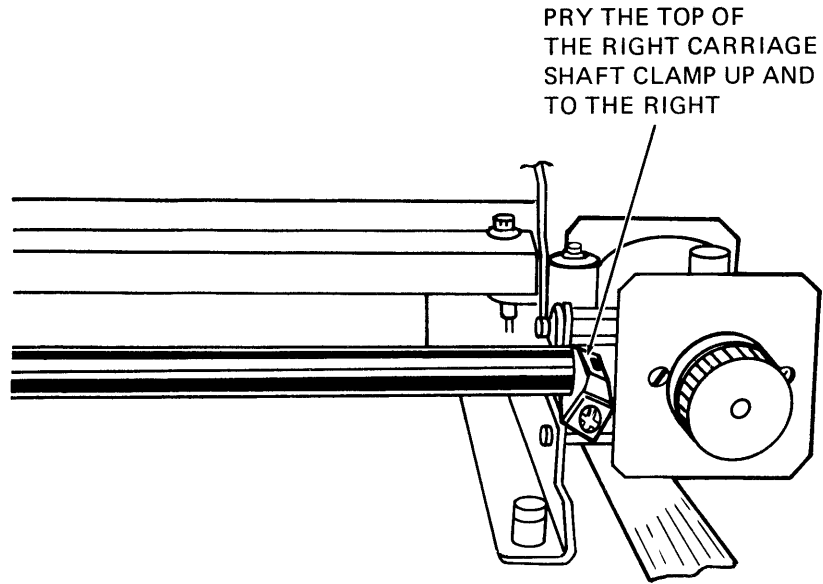

MA-2591

b. Prying Up Carriage Shaft Clamp

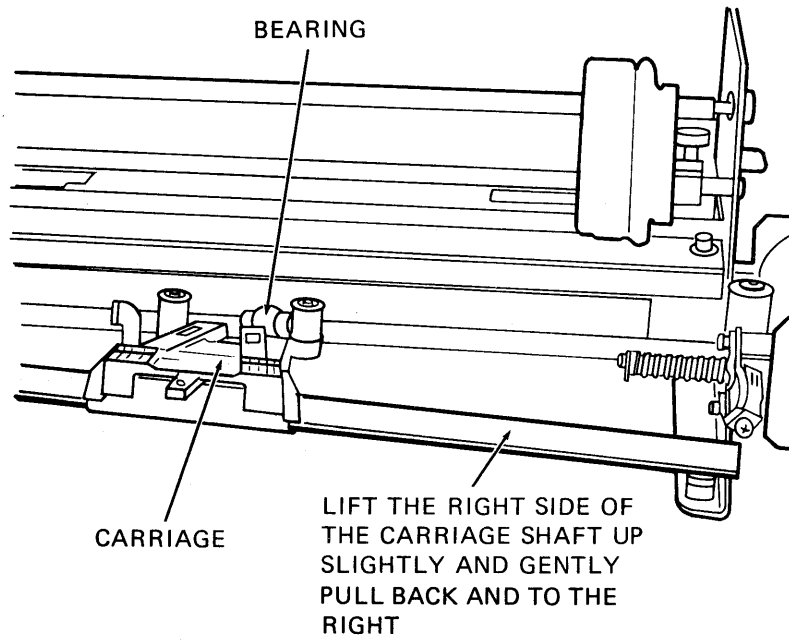

MA-2592

c. Lifting Front Carriage Shaft

Figure 6-7 Carriage Assembly and Front Carriage Shaft Removal and Installation (Sheet 2 of 2)

8. To remove carriage and carriage shaft, lift right side of the carriage shaft up slightly and gently pull back and to the right as shown in Figure 6-7c.
9. Remove carriage from carriage shaft.

6.7.2 Carriage Assembly and Front Carriage Shaft Installation

1. Place new carriage on carriage shaft.
2. Slide left side of carriage shaft into carriage shaft clamp.
3. Align carriage and bearing and snap the right side of the carriage shaft into carriage shaft clamp. Ensure that carriage shaft clamp is seated properly.
4. Tighten left and right 8-32 carriage clamp screws, 18 ± 2 in/lbs of torque.
5. Holding belt tension spring in place (Figure 6-6), slip on the timing belt.
6. Replace keyboard bezel on cabinet base and secure by pressing in two sides of bezel to engage mounting slots. Check keyboard connectors to ensure they are properly seated.
7. Perform timing belt installation procedure (Paragraph 6.5.2).
8. Perform print head installation procedure (Paragraph 6.3.2).
9. Perform the printer housing installation procedure (Paragraph 6.2.2).

6.8 CARRIAGE ECCENTRIC BEARING AND LEVER

Refer to Figure 6-8 during the removal and installation procedures.

6.8.1 Carriage Eccentric Bearing and Lever Removal

1. Remove carriage assembly (Paragraph 6.7.1).
2. Remove carriage spring holding eccentric bearing in place. Spring is removed by pressing up on spring while pushing spring tab toward rear of carriage assembly.
3. Remove eccentric bearing.
4. Pull lever off the end of the eccentric bearing.

6.8.2 Carriage Eccentric Bearing and Lever Installation

1. Press lever onto end of eccentric bearing with stop detents facing in toward carriage assembly.
2. Place eccentric bearing in carriage assembly with lever dial toward top of carriage assembly. Place oil on the eccentric bearing where carriage spring rubs against it.
3. Install carriage spring by pressing up on spring until spring tab snaps into place.
4. Install carriage assembly (Paragraph 6.7.2).

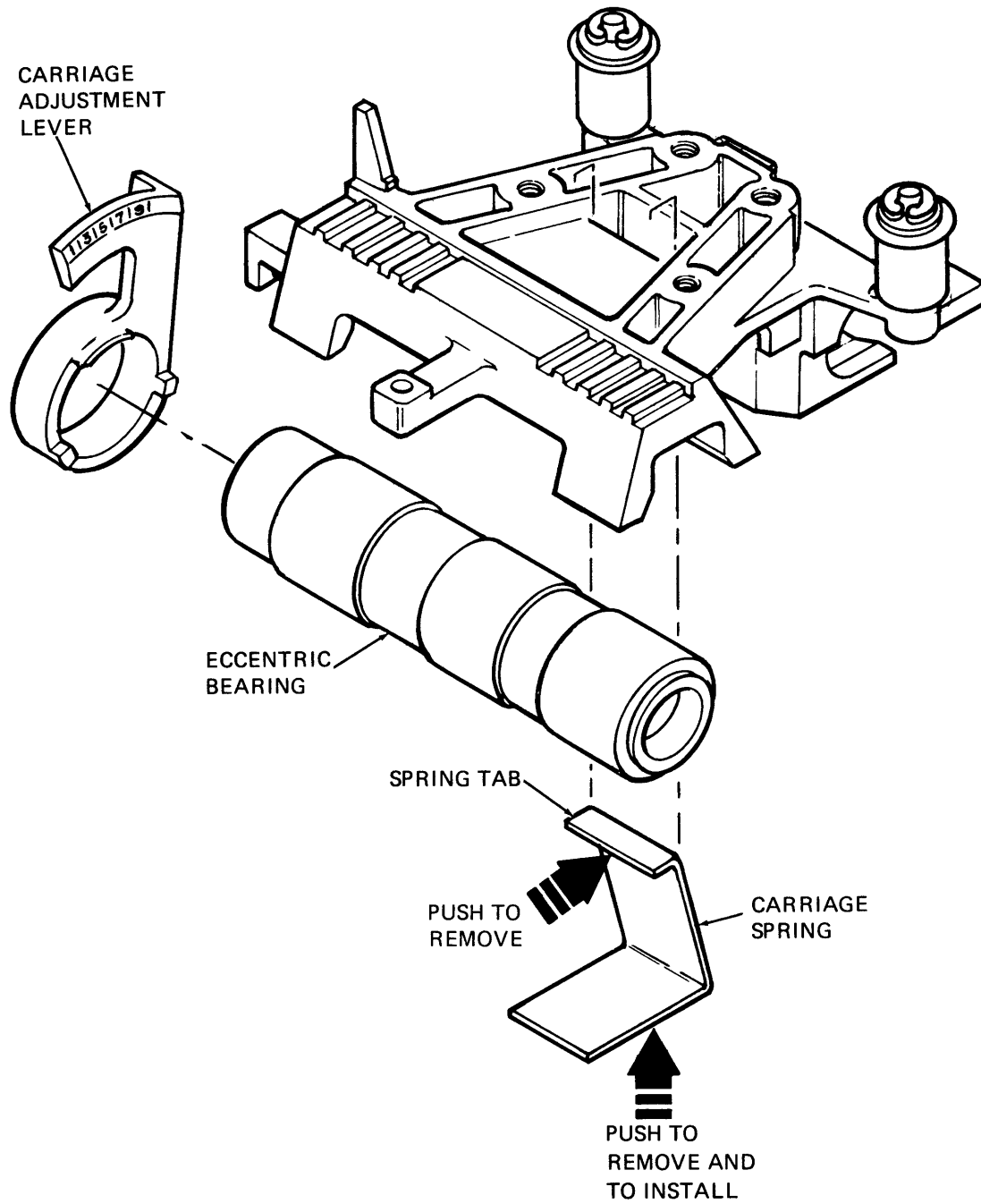

MA-4507

Figure 6-8 Carriage Eccentric Bearing and Lever Removal and Installation

6.9 REAR CARRIAGE SHAFT AND PLAIN BUSHING

Refer to Figure 6-9 during the removal and installation procedures.

6.9.1 Rear Carriage Shaft and Plain Bushing Removal

1. Remove carriage assembly and front carriage shaft (Paragraph 6.7.1).
2. Separate ribbon chassis assembly from right end plate by removing 1/4 inch hex-head screw and two Phillips screws.
3. Separate print bar from right end plate by removing 3/8 inch hex-head screw from right end of the print bar.

NOTE

Try not to move print bar. Do not loosen screw on left end of print bar.

4. Separate right end plate from printer frame by removing two 5/16 inch hex-head mounting screws from underneath frame.
5. Carefully work right end plate toward the right until right end of the rear carriage shaft slips out of right end plate. Support right end of the upper tractor shaft, which will slip out of its bearing when right plate is moved.
6. Slide plain bushing off rear carriage shaft.
7. Carefully work rear carriage shaft out of left end plate.

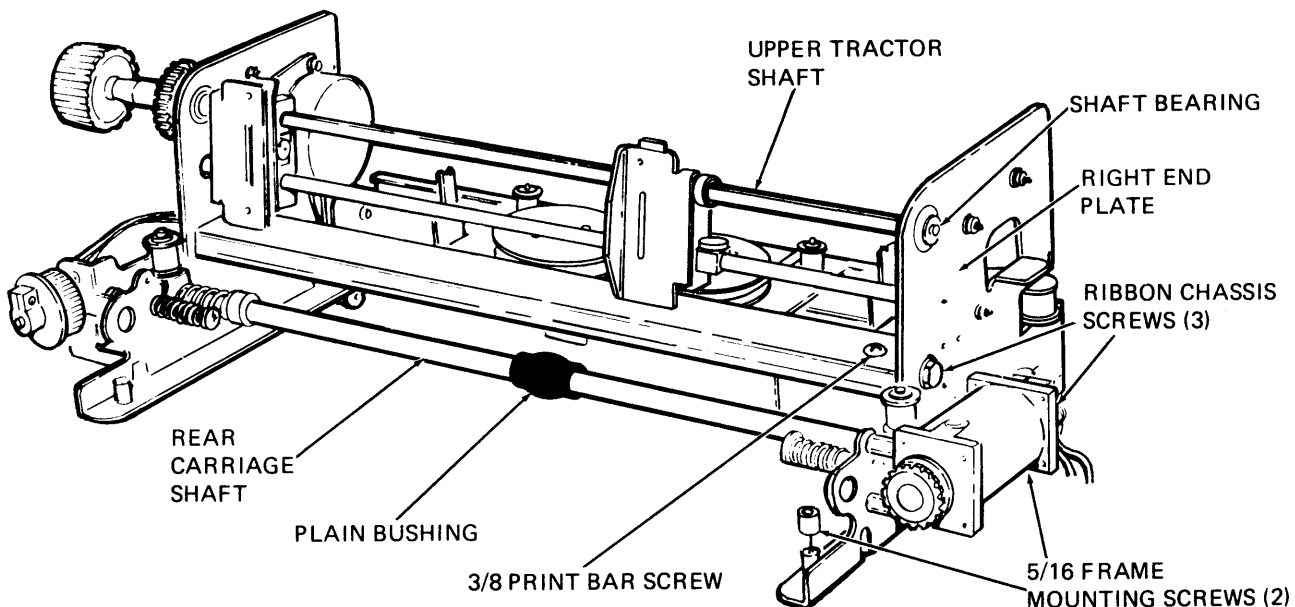

MA-4508

Figure 6-9 Rear Carriage Shaft and Plain Bushing Removal and Installation

6.9.2 Rear Carriage Shaft and Plain Bushing Installation

1. Slip rear carriage shaft into shaft hole in left end plate.
2. Slide plain bushing onto rear carriage shaft.
3. Work right end plate into position while simultaneously inserting right end of rear carriage shaft and right end of upper tractor shaft into right end plate.
4. Attach right end plate to printer frame by installing two 5/16 inch hex-head mounting screws underneath frame.
5. Attach print bar to right end plate by installing 3/8 inch hex-head screw into right end of print bar.

NOTE

Try not to move print bar.

6. Attach ribbon chassis assembly to right end plate with 1/4 inch hex-head screw and two Phillips head screws.
7. Install carriage assembly and front carriage shaft (Paragraph 6.7.2).
8. Check print bar adjustment (Paragraph 7.9).

6.10 RIBBON DRIVE PULLEY

The following procedure describes the removal and installation of the ribbon drive pulley. Refer to Figure 6-10 during the procedure.

6.10.1 Ribbon Drive Pulley Removal

1. Perform printer housing removal procedure (Paragraph 6.2.1).
2. Slip timing belt off dc motor pulley.
3. Loosen 6-32 Allen-cap screw that secures collar clamp and drive pulley to ribbon drive shaft. Remove collar clamp and drive pulley.

6.10.2 Ribbon Drive Pulley Installation

1. Remove collar clamp from defective pulley and hand press it onto new drive pulley. Line up front edges of collar clamp and drive pulley.
2. Replace ribbon drive pulley and collar clamp on ribbon drive shaft and adjust them to give a clearance of 0.38 ± 0.03 inch between ribbon drive bracket and ribbon drive pulley. Tighten 6-32 screw to 12 ± 2 in/lb of torque.
3. Slip timing belt onto pulley.
4. Perform printer housing installation procedure (Paragraph 6.2.2).

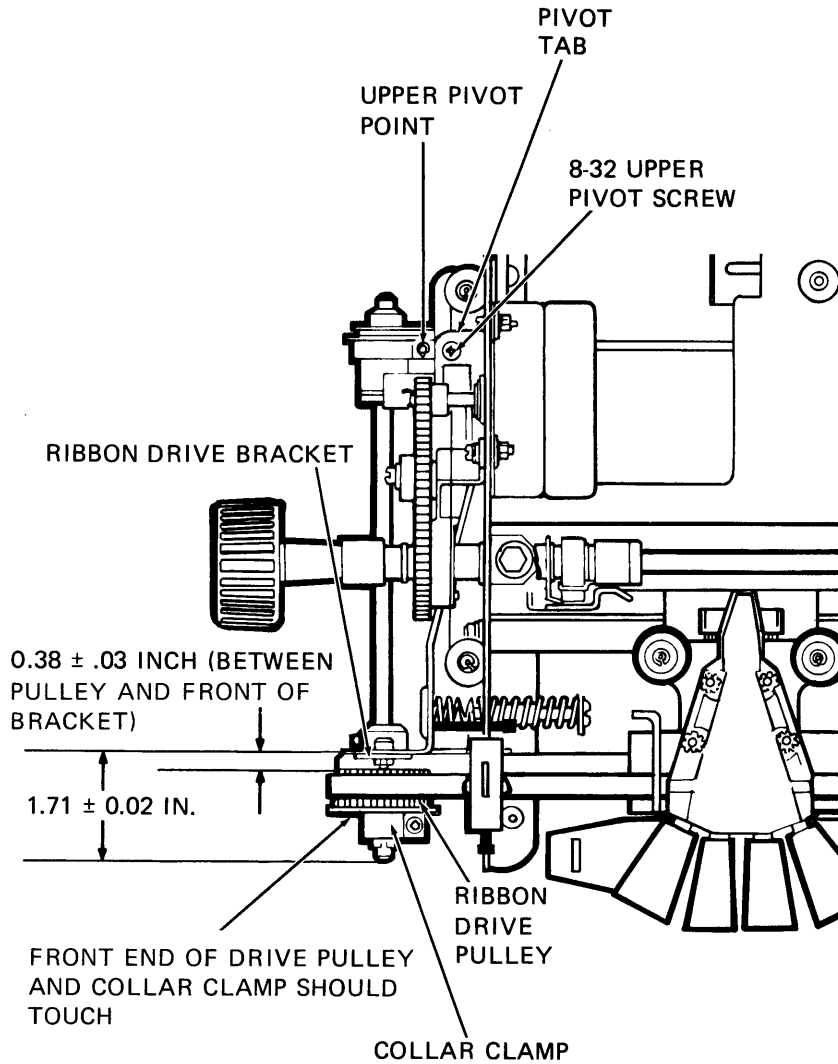

MA-2574

Figure 6-10 Ribbon Drive Pulley Removal and Installation

6.11 RIBBON DRIVE ASSEMBLY

The following procedure describes the removal and installation of the ribbon drive assembly. Refer to Figures 6-11 and 6-12 during the procedure.

6.11.1 Ribbon Drive Assembly Removal

1. Perform printer housing removal procedure (Paragraph 6.2.1).
2. Remove ribbon spools and ribbon.
3. Slip timing belt off dc motor pulley.
4. Lift up pushrod and remove retaining ring that holds pushrod in ribbon chassis.
5. Rotate ribbon drive pulley until clutch eccentric is at its highest point.

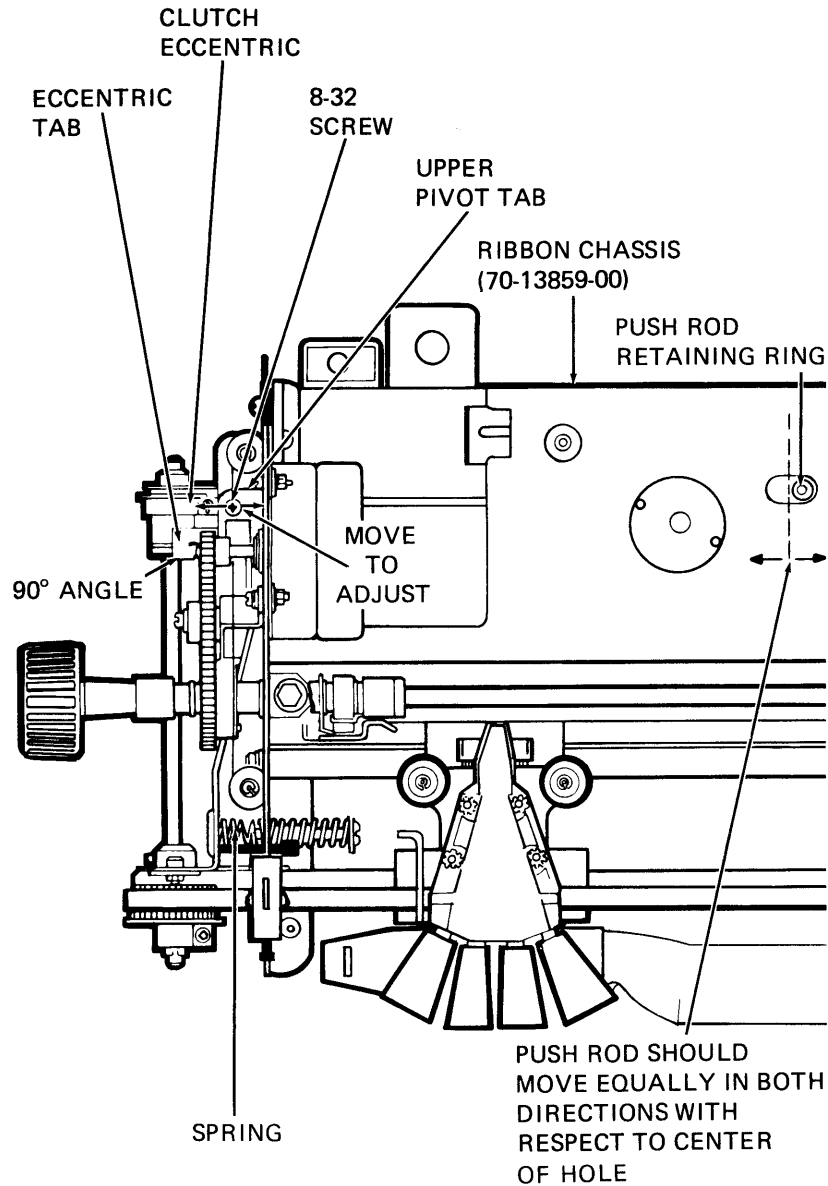

MA-2572

Figure 6-11 Ribbon Drive Assembly Removal and Installation

6. Remove 8-32 screw and washer that secure ribbon drive to upper pivot tab on left-hand side plate.
7. Remove ribbon drive by pulling out at top. This will free assembly from upper pivot tab. Lift up on ribbon drive to clear lower pivot.

NOTE

The nut on the ribbon drive assembly is loose and can be lost easily.

8. Carefully remove ribbon drive assembly and pushrod.

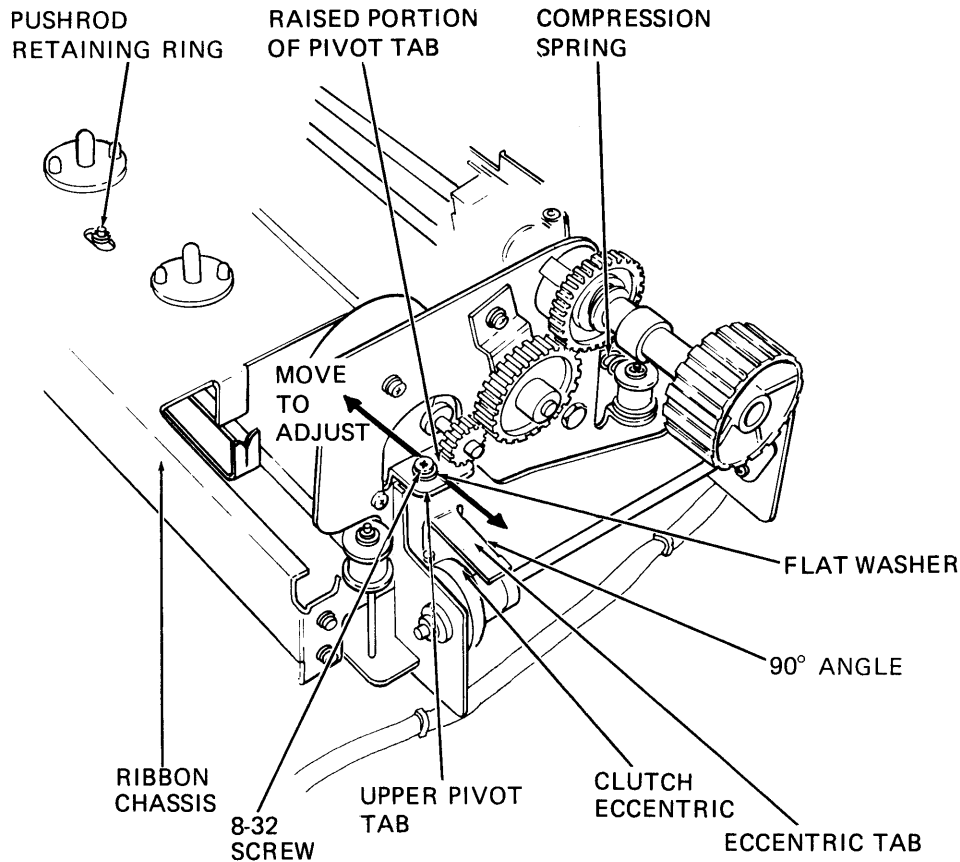

MA-2573

Figure 6-12 Ribbon Drive Assembly (Detailed View)

6.11.2 Ribbon Drive Assembly Installation

1. Rotate the ribbon drive pulley on new ribbon drive assembly until clutch eccentric is at its highest point.

NOTE

Ensure that PAPER OUT switch wires are under pushrod when installing ribbon drive assembly.

2. Push pushrod through left-hand side plate.
3. Push rear of drive assembly toward side plate and engage lower pivot point.
4. Slide upper pivot under pivot tab on side plate and secure it with 8-32 screw and flat washer. Make screw finger tight.
5. Replace retaining ring that holds pushrod in ribbon chassis.
6. Insert compression spring between left-hand side plate and ribbon drive.
7. Replace timing belt on ribbon drive pulley and dc motor pulley.

8. Rotate ribbon drive and check pushrod travel to either side of center of the elongated slot in the ribbon chassis. Travel should be equal on either side of center.
9. To attain equal travel from center, move ribbon drive upper pivot point in direction of the shortest distance of travel. When travel is equal on both sides of the elongated hole, tighten 8-32 upper pivot screw to 18 ± 2 in/lb of torque.

NOTE

Check that eccentric tab is bent at a 90 degree angle when viewed from the left side of unit. If angle is not 90 degrees, bend it to correct angle. This is done to prevent tab from touching spring. Clearance should be 0.254 to 0.508 mm (0.010 to 0.020 in).

10. Replace ribbon and ribbon spools.
11. Perform printer housing installation procedure (Paragraph 6.2.2).

6.12 RIBBON DRIVE FAFNIR BEARING

The following procedure describes the removal and installation of the ribbon drive Fafnir bearing. Refer to Figure 6-13 during the procedure. To perform this procedure, the ribbon drive assembly must be removed.

6.12.1 Ribbon Drive Fafnir Bearing Removal

1. Perform ribbon drive assembly removal procedure (Paragraph 6.11.1).
2. Loosen 6-32 Allen head screw that secures collar clamp and drive pulley to ribbon drive shaft. Remove collar clamp and drive pulley (Figure 6-10).
3. Remove two (8-32) screws, nuts, and lockwashers that secure Fafnir bearing to ribbon drive bracket.
4. Loosen 4-40 set screw that secures Fafnir bearing on ribbon drive shaft.
5. While rotating ribbon drive shaft counterclockwise, push shaft toward rear of ribbon drive assembly until it clears ribbon drive bracket. (Always turn shaft in a counterclockwise direction when pushing through the one-way clutch.)
6. Remove Fafnir bearing from ribbon drive shaft and set bearing aside.

6.12.2 Ribbon Drive Fafnir Bearing Installation

1. Place new Fafnir bearing on ribbon drive shaft and push shaft toward pulley end of ribbon drive until Fafnir bearing can be seated in ribbon drive bracket. (Always turn shaft in a counterclockwise direction when pushing through the one-way clutch.)
2. Secure Fafnir bearing to ribbon drive bracket with two (8-32) screws, nuts, and lockwashers. The nuts go on outside of ribbon drive bracket.
3. Slide ribbon drive shaft toward front of ribbon drive until it extends 1.71 ± 0.02 inch beyond ribbon drive bracket (Figure 6-10). Tighten 4-40 set-screw in Fafnir bearing to 8 ± 1 in/lb of torque. (The set-screw sets into a recessed dimple in Fafnir bearing split collar.) Turn shaft in a clockwise direction to ensure freedom of movement.

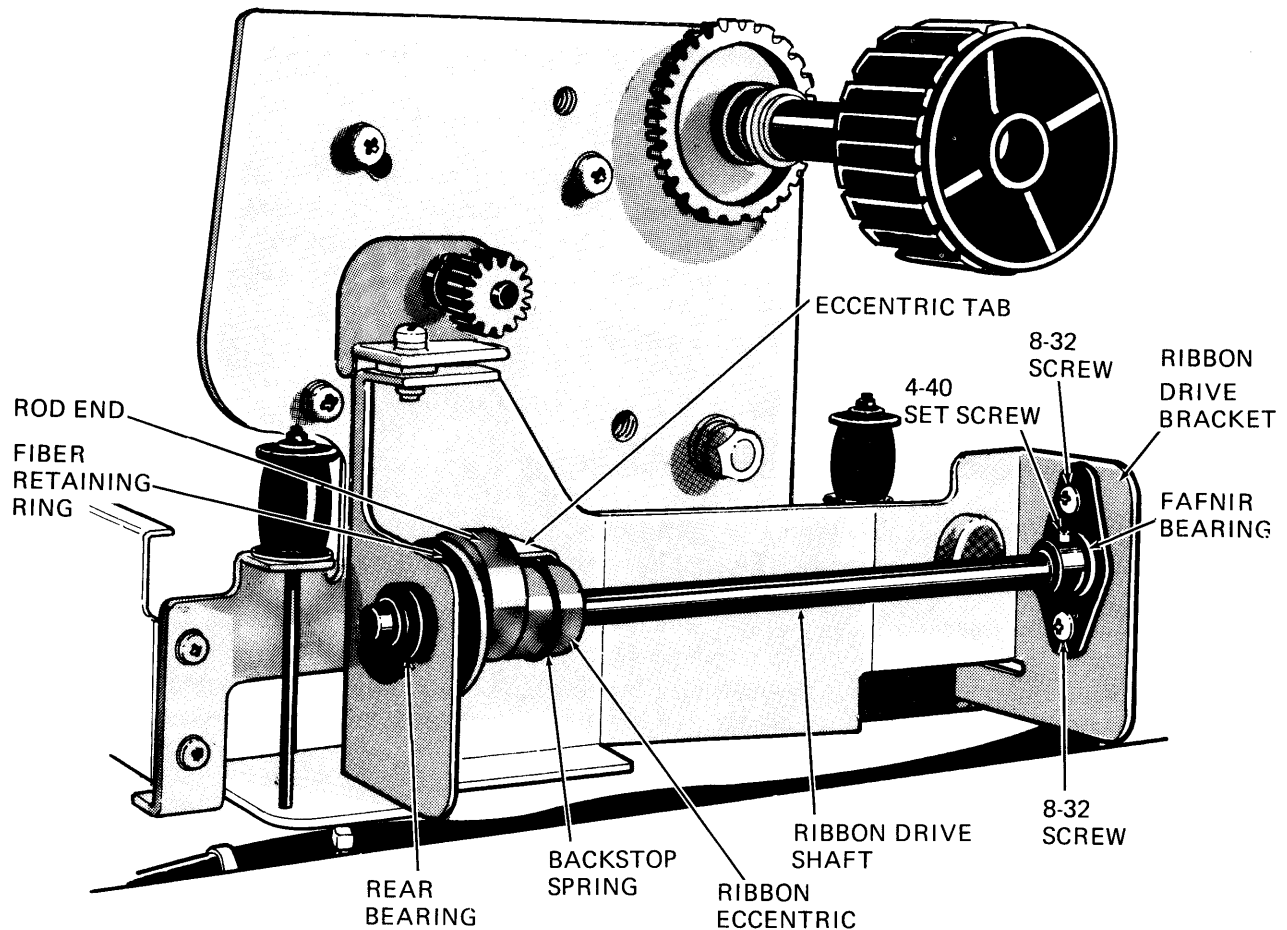

MA-4694

Figure 6-13 Fafnir Bearing and Ribbon Eccentric Removal and Installation

4. Replace ribbon drive pulley and collar clamp on ribbon drive shaft and adjust them to give a clearance of 0.38 ± 0.03 inch between ribbon drive bracket and ribbon drive pulley. Tighten 6-32 Allen head screw in collar clamp to 12 ± 2 in/lb of torque.
5. Check that backstop spring coils do not overlap.
6. Perform ribbon drive assembly installation procedure (Paragraph 6.11.2).

6.13 RIBBON ECCENTRIC AND BACKSTOP SPRING

The following procedure describes the removal and installation of the ribbon eccentric and backstop spring. Refer to Figure 6-13 during the procedure. To perform this procedure the ribbon drive assembly must be removed.

6.13.1 Ribbon Eccentric and Backstop Spring Removal

1. Perform ribbon drive assembly removal procedure (Paragraph 6.11.1).
2. Loosen 6-32 Allen head screw that secures collar clamp and drive pulley to ribbon drive shaft. Remove collar clamp and drive pulley (Figure 6-10).

3. Loosen 4-40 set screw that secures Fafnir bearing on ribbon drive shaft.
4. Remove retaining ring that holds pushrod in rod end.
5. While rotating ribbon drive shaft counterclockwise, push shaft toward rear of ribbon drive assembly until it is completely removed. (Always turn shaft in a counterclockwise direction when pushing through one-way clutch.) The fiber retaining ring will fall free. Support the ribbon eccentric and backstop spring which is still attached to the eccentric tab.
6. Disengage backstop spring from eccentric tab.
7. Separate rod end, ribbon eccentric, and backstop spring.

6.13.2 Ribbon Eccentric and Backstop Spring Installation

1. Install (new) backstop spring on (new) ribbon eccentric. Apply one drop of No. 30 SAE oil on spring and on eccentric. Engage backstop spring with eccentric tab.
2. Install rod end on eccentric.
3. Slide ribbon drive shaft through rear bearing, fiber retaining ring, ribbon eccentric, Fafnir bearing, and ribbon drive bracket. (Always turn shaft in a counterclockwise direction when pushing through the one-way clutch.)
4. Slide pushrod into rod end and replace retaining ring.
5. Slide ribbon drive shaft toward front of ribbon drive until it extends 1.71 ± 0.02 inch beyond ribbon drive bracket (Figure 6-10). Tighten 4-40 set-screw in Fafnir bearing to 8 ± 1 in/lb of torque. (The set-screw sets into a recessed dimple in Fafnir bearing split collar.) Turn shaft in a clockwise direction to ensure freedom of movement.
6. Replace ribbon drive pulley and collar clamp on ribbon drive shaft and adjust them to give a clearance of 0.38 ± 0.03 inch between ribbon drive bracket and ribbon drive pulley (Figure 6-10). Tighten 6-32 Allen head screw in collar clamp to 12 ± 2 in/lb of torque.
7. Check that backstop spring coils do not overlap.
8. Perform ribbon drive assembly installation procedure (Paragraph 6.11.2).

6.14 DC MOTOR AND ENCODER ASSEMBLY

The following procedure describes the removal and installation of the dc motor and encoder assembly. Refer to Figure 6-14 during the procedure.

6.14.1 DC Motor and Encoder Assembly Removal

1. Perform printer housing removal procedure (Paragraph 6.2.1).
2. Slip timing belt off dc motor pulley.
3. Open rear access door on cabinet.
4. Disconnect connectors from J5 and J7 on the logic/power board (Figure 5-1).

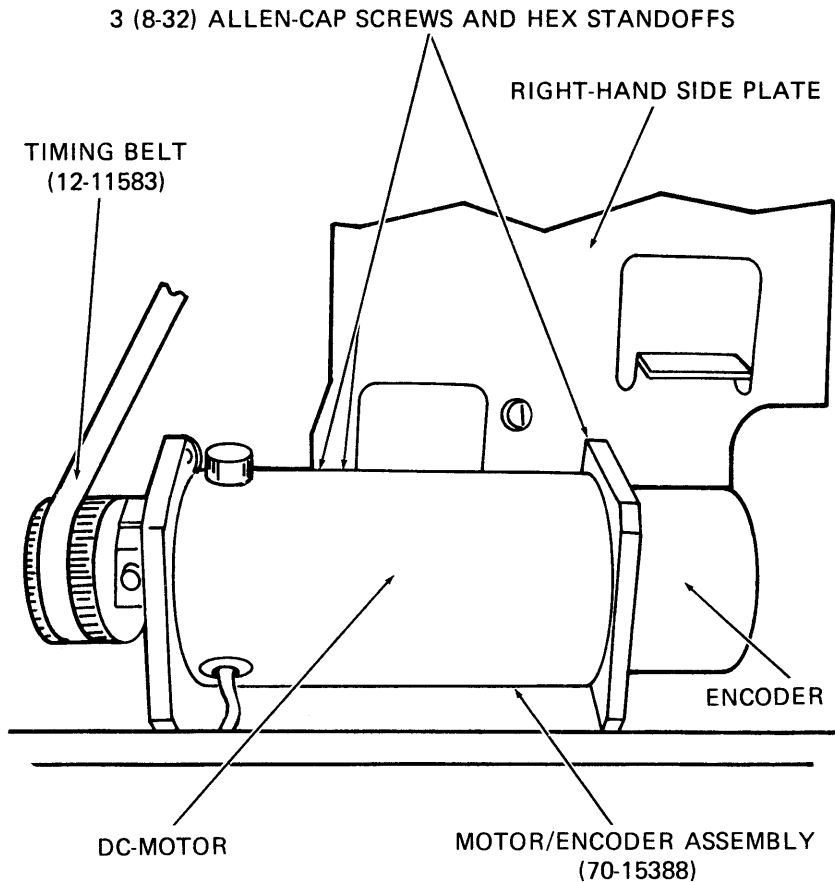

MA-2575

Figure 6-14 DC Motor/Encoder Assembly Removal and Installation

5. Remove three (8-32) Allen-cap screws and hex standoffs that secure dc motor to right-hand side plate and remove motor.

6.14.2 DC Motor and Encoder Assembly Installation

1. Secure new dc motor to right-hand side plate with three (8-32) Allen-cap screws and hex standoffs. Tighten screws to 18 ± 2 in/lb.
2. Thread dc motor and encoder cables down through slot at rear of cabinet.
3. Secure cables with cable ties where needed. Reconnect connectors to J5 and J7 on logic/power board.
4. With belt tension spring (Figure 6-5) in place, press left-hand pulley against printer mechanism and slip on new timing belt.
5. Perform printer housing installation procedure (Paragraph 6.2.2).

6.15 TRACTOR DRIVE SHAFTS AND TRACTOR ASSEMBLIES

The following procedure describes the removal and installation of tractor drive shafts and tractor assemblies. Tractor assemblies slip off the drive shafts once the shafts are removed. Refer to Figure 6-15 during the procedure.

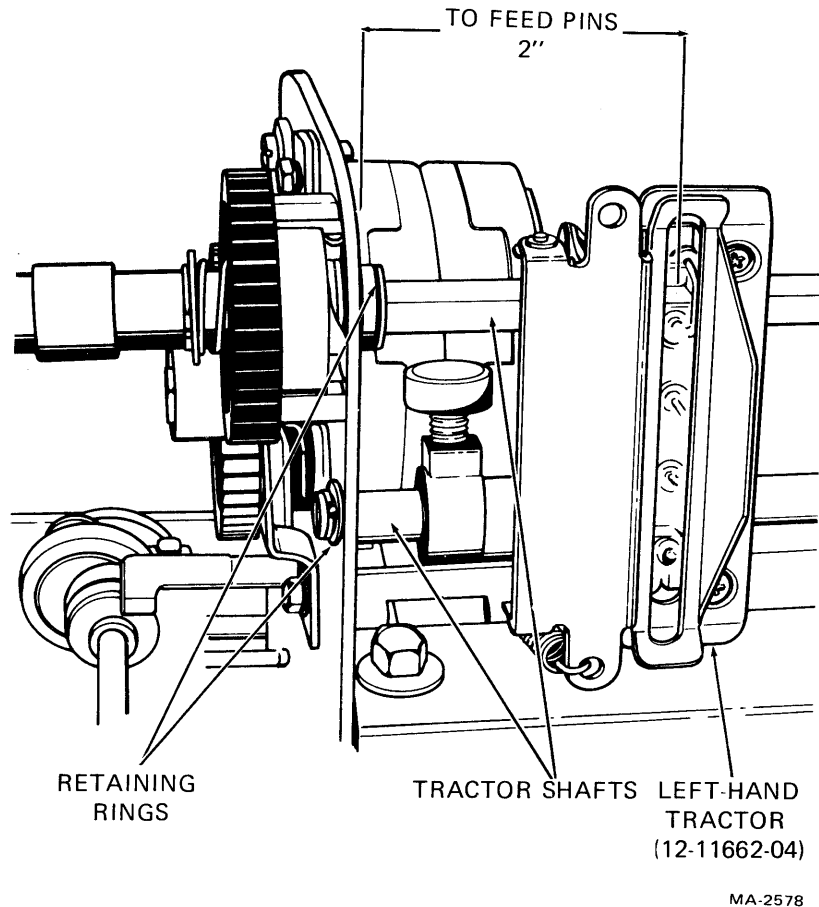

Figure 6-15 Tractor Drive Shaft and Tractor Assembly Removal and Installation

6.15.1 Tractor Drive Shaft and Tractor Assembly Removal

1. Perform printer housing removal procedure (Paragraph 6.2.1).
2. Loosen tractor adjustments knob on both tractors.

NOTE

The spring clip on the outside of the lower tractor support shaft is loose and may fall off when performing the following step.

3. Remove two retaining rings on left-hand side of tractor support shaft and drive shaft.
4. Slide both shafts to left about 10.16 cm (4 in) to remove the tractor assemblies. Pull shafts (to the left) out of the left-hand end plate to remove shafts.

6.15.2 Tractor Drive Shaft and Tractor Assembly Installation

1. Replace defective tractor or drive shaft.
2. Slide two tractor shafts halfway through left-side plate.
3. Slide tractor assemblies on tractor shafts.
4. Ensure that index marks on outside of upper tractor bushings coincide with same flat on square shaft (Figure 6-16). If bushings are not scribed, rotate tractors until a tractor pin on both tractors is centered on the same flat.

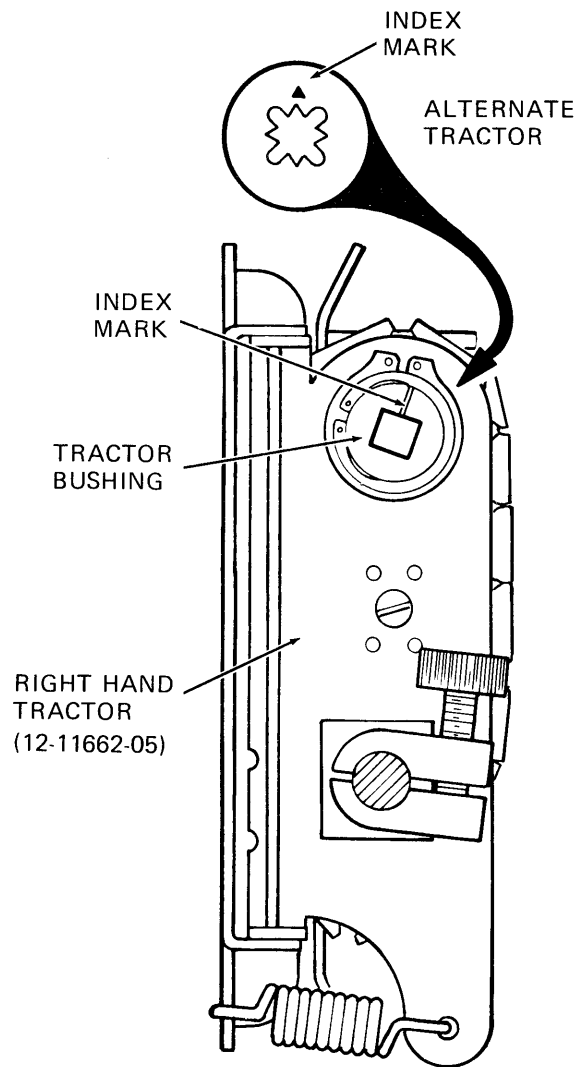

TRACTOR PHASING

MA-2579

Figure 6-16 Tractor Phasing Adjustment

5. Position tractor shafts in side plates and secure them with three retaining rings.
6. Slide left-hand tractor from side to side. If it appears to bind or have excessive drag on the shafts, grasp bottom tractor shaft and move it up or down in its slot until tractor slides easily on shafts.
7. Slide left-hand tractor to left so that feed pins are 53.975 mm (2.112 ± 0.03 in) from left-hand side plate.
8. The right-hand tractor is adjusted to the width of paper or form to be used.
9. Perform printer housing installation procedure (Paragraph 6.2.2).

6.16 IDLER GEAR ASSEMBLY

The following procedure describes the removal and installation of the idler gear assembly. Refer to Figure 6-17 during the procedure.

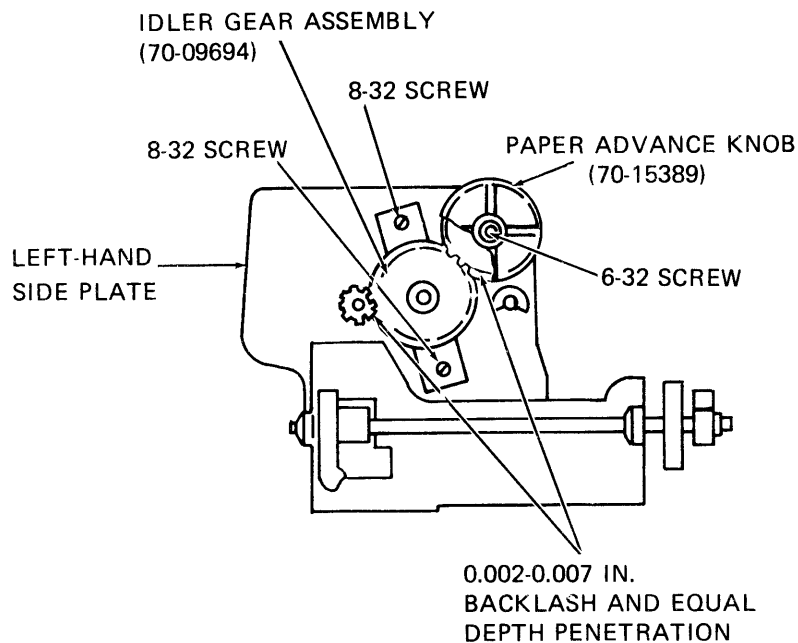

Figure 6-17 Idler Gear Assembly Removal and Installation

6.16.1 Idler Gear Assembly Removal

1. Perform printer housing removal procedure (Paragraph 6.2.1).
2. Remove two (8-32) screws, lockwashers, and flat washers that secure idler gear assembly to left-hand side plate.

6.16.2 Idler Gear Assembly Installation

1. Secure new idler gear assembly to left-hand side plate with two (8-32) screws, lockwashers, and flat washers. Make screws finger tight.

2. With idler gear in mesh with stepping motor gear and tractor drive gear, adjust idler gear to achieve equal depth penetration and a backlash* of 0.0508 to 0.1778 mm (0.002 to 0.007 in) between each pair of gears. The idler gear should be free to slide in and out. Rotate gears to check backlash in several places.
3. Tighten two (8-32) screws to 18 ± 2 in/lb of torque.
4. Rotate paper advance knob to ensure that gears turn freely.
5. Perform printer housing installation procedure (Paragraph 6.2.2).

6.17 STEPPING MOTOR ASSEMBLY

The following procedure describes the removal and installation of the stepping motor. The idler gear assembly must be removed to remove the stepping motor assembly. Refer to Figures 6-18 and 6-19 during the procedure.

6.17.1 Stepping Motor Assembly Removal

1. Perform printer housing removal procedure (Paragraph 6.2.1).
2. Perform idler gear assembly removal procedure (Paragraph 6.16.1).
3. Open rear access door.

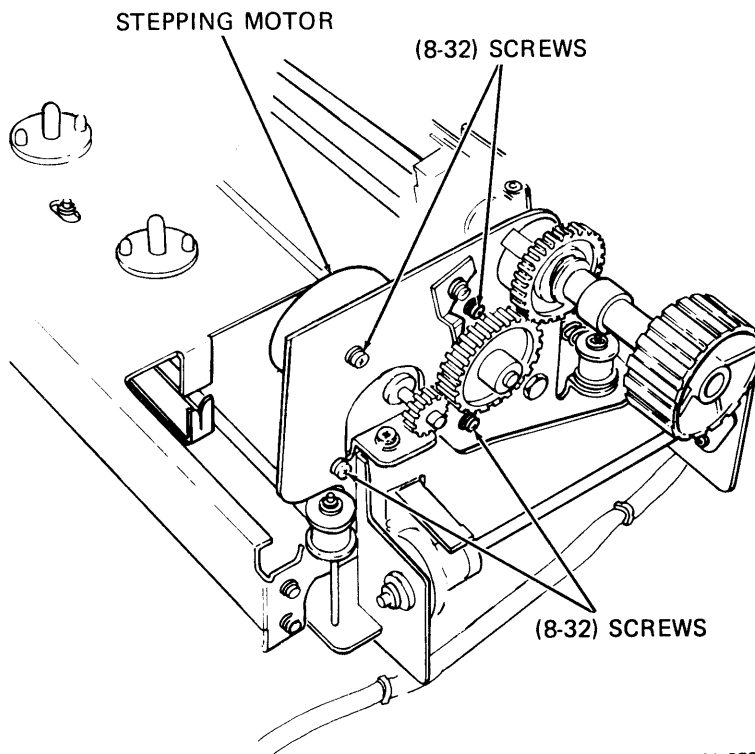

MA-2583

Figure 6-18 Stepping Motor Assembly Removal and Installation

*Backlash is the amount a gear turns prior to turning the gear it meshes with.

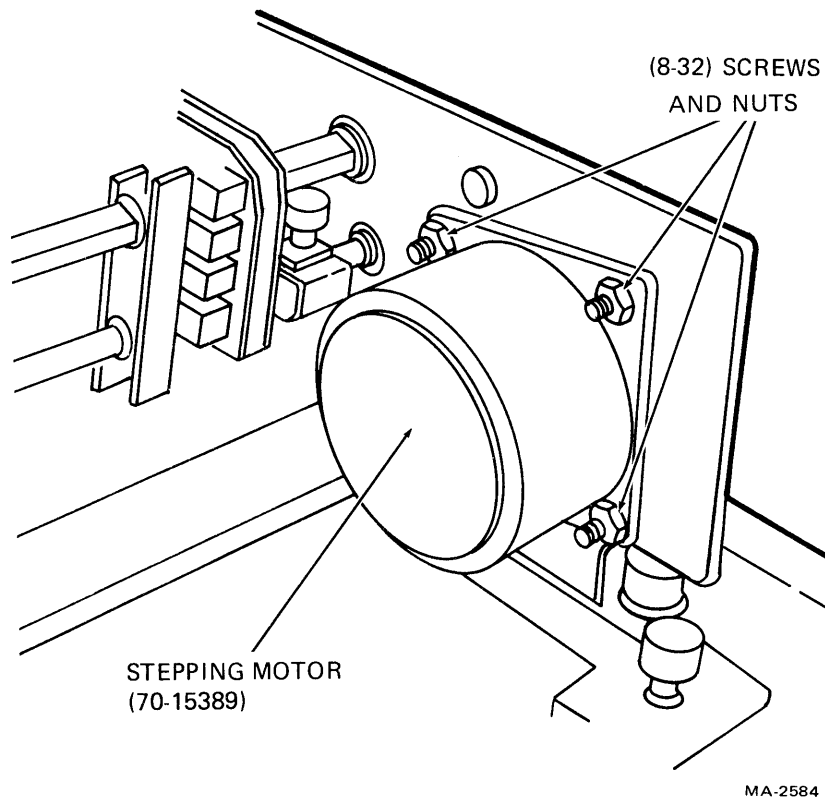

Figure 6-19 Stepping Motor Mounted on Side Plate

4. Disconnect stepping motor from connector J3 on logic/power board (Figure 5-1) and clip necessary cable ties. Disconnect speaker leads.
5. Pull wires up through slot at rear of cabinet.
6. Remove four (8-32) screws, flat washers, lockwashers, and hex nuts that secure stepping motor to left-hand side plate. Set stepping motor aside.

6.17.2 Stepping Motor Assembly Installation

1. Secure new stepping motor to left-hand side plate with four (8-32) screws, flat washers, lockwashers, and hex nuts. **Install lower-left mounting screw first.** The hex nut and lockwashers go on the inside of the left-hand side plate. Allow stepping motor to drop to its lowest point in the elongated slots.
2. Tighten four (8-32) screws to 18 ± 2 in/lb of torque.
3. Reconnect connector to J3 on logic/power board. Secure stepping motor wires with cable ties and thread them under printer mechanism and pushrod and down through slot at rear of cabinet. Connect speaker leads to speaker.
4. Close rear access door.
5. Perform idler gear assembly installation procedure (Paragraph 6.16.2).
6. Perform printer housing installation procedure (Paragraph 6.2.2).

6.18 RIBBON CHASSIS ASSEMBLY

The following procedure describes the removal and installation of the ribbon chassis assembly. Refer to Figure 6-20 during the procedure.

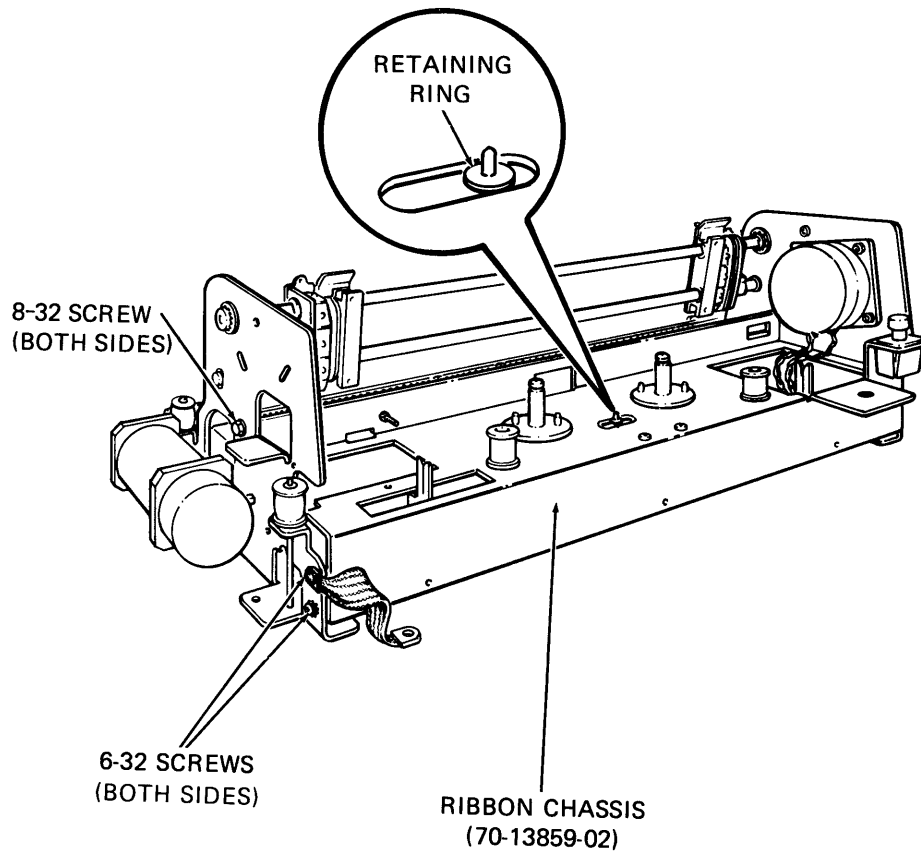

MA-2580

Figure 6-20 Ribbon Chassis Assembly Removal and Installation

6.18.1 Ribbon Chassis Assembly Removal

1. Perform printer housing removal procedure (Paragraph 6.2.1).
2. Remove ribbon spools and ribbon.
3. Remove retaining ring that holds pushrod in ribbon chassis.
4. Remove four (6-32) screws, flat washer, and star washers that secure ribbon chassis to right- and left-hand side plates.
5. Remove two (8-32) screws and washers that secure ribbon chassis to right- and left-hand side plates.
6. Remove idler gear (Paragraph 6.16.1).
7. Remove stepping motor (Paragraph 6.17.1) and rest it on printer base.

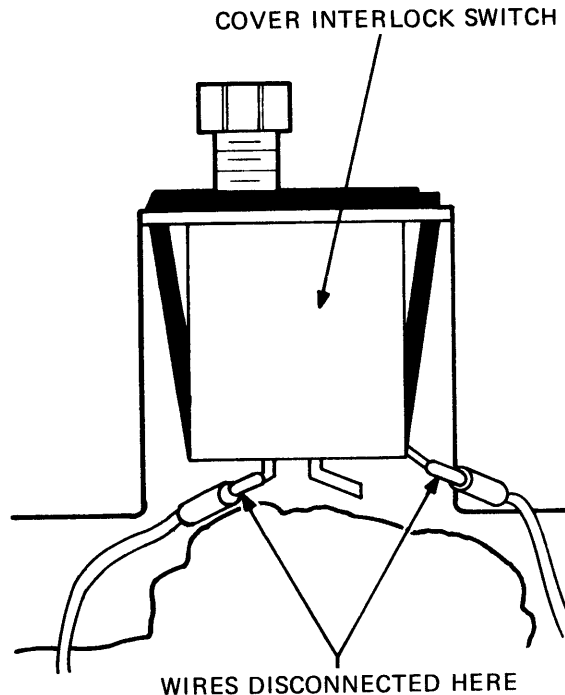

MA-2581

Figure 6-21 Cover Interlock Switch

8. Remove cover interlock switch (Figure 6-21).
9. Remove ribbon chassis and set it aside.

6.18.2 Ribbon Chassis Assembly Installation

1. Secure ribbon chassis to right- and left-hand side plates with two (8-32) screws and lockwashers. Torque the screws to 18 ± 2 in/lb.
2. Replace four (6-32) screws and lockwashers that secure ribbon chassis to right- and left-hand side plates. Torque the screws to 12 ± 2 in/lb.
3. Install stepping motor (Paragraph 6.17.2).
4. Install idler gear (Paragraph 6.16.2).
5. Line up hole in ribbon chassis with pushrod, and replace retaining ring that holds pushrod in place.
6. Install cover interlock switch.
7. Install ribbon spools and ribbon.
8. Install printer housing (Paragraph 6.2.2).

6.19 RIBBON SPOOL RATCHET WHEELS AND FRICTION DISKS

The following procedure describes the removal and installation of the ribbon spool ratchet wheel(s) and friction disks. The ribbon chassis assembly must be removed first in order to remove the ribbon spool ratchet wheel(s) and friction disks. Refer to Figure 6-22 during the procedure.

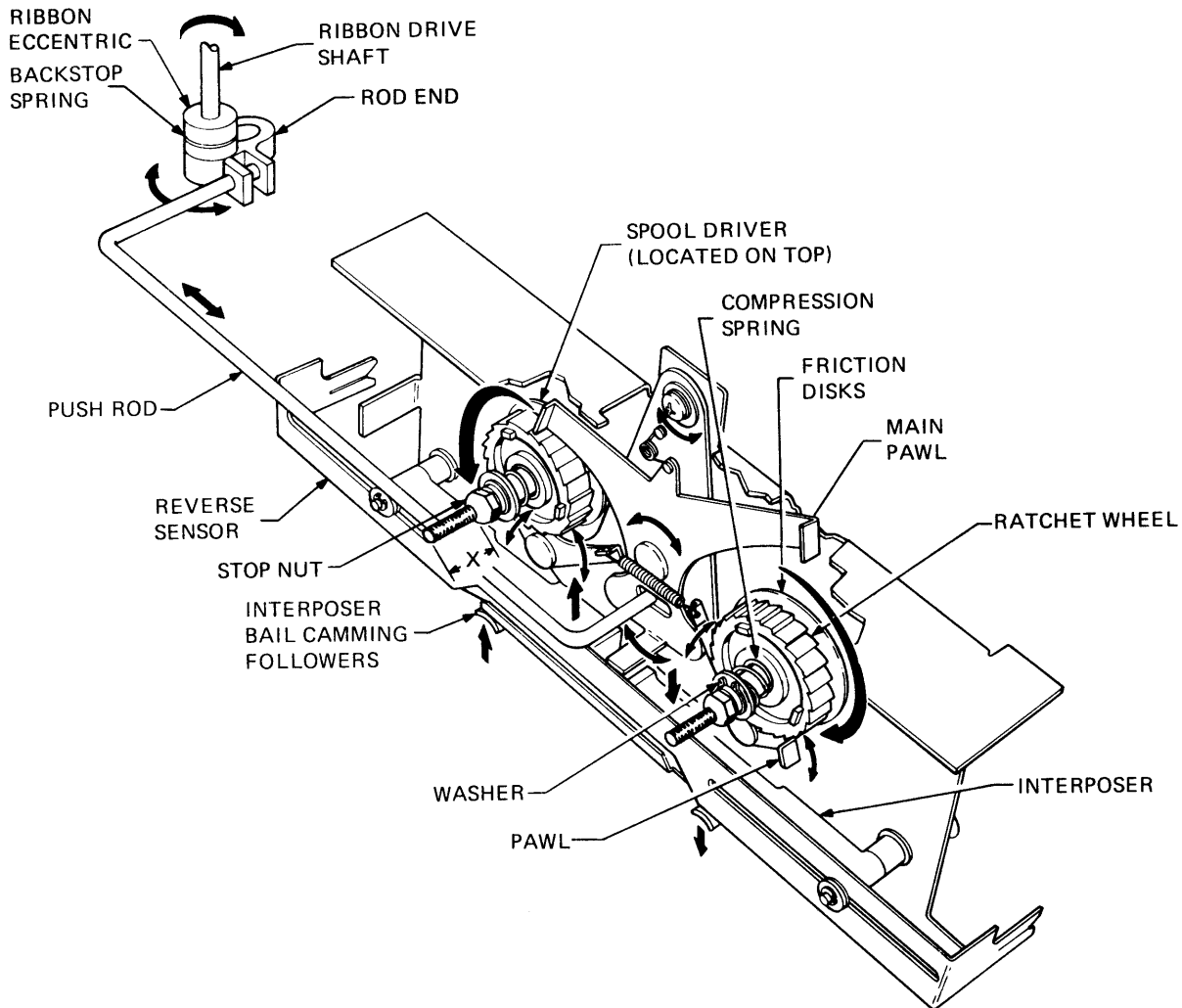

MA-4509

Figure 6-22 Ribbon Spool Ratchet Wheel and Friction Disk Replacement

6.19.1 Ribbon Spool Ratchet Wheel(s) and Friction Disk Removal

1. Perform ribbon chassis assembly removal procedure (Paragraph 6.18.1).
2. Measure distance (X) from stop nut to end of screw.
3. Remove stop nut.

4. Remove washers, compression spring, ratchet wheel, spool driver, and screw being careful to note the order in which parts are removed. (See Illustrated Parts Breakdown for an exploded view.)

NOTE

Before removing the ratchet wheel, note the direction of the ratchet wheel teeth. When ratchet wheel is replaced, teeth must be orientated in the same direction.

5. Remove four old friction disks from ratchet wheel, spool driver, and ribbon chassis. Clean each mounting surface.
6. Remove protective paper from four new friction disks and apply one each to spool driver, ratchet wheel, and to each side of the ribbon chassis. Ensure that friction disk is applied to the side of the ratchet wheel that faces the ribbon chassis. Ensure that surfaces are free of oil and moisture.

6.19.2 Ribbon Spool Ratchet Wheel(s) and Friction Disk Installation

1. Replace screw, spool driver, ratchet wheel, compression spring, and washers. Ensure that ratchet wheel teeth point in the proper direction as shown in Figure 6-22.
2. Replace stop nut. Adjust nut to position on screw noted in Step 2 of Paragraph 6.19.1.
3. Check ribbon tension adjustment (Paragraph 7.5). Readjust stop nut if necessary.
4. Perform ribbon chassis assembly installation procedure (Paragraph 6.18.2).

6.20 KEYBOARD/NUMERIC PAD ASSEMBLY

The following procedure describes the removal and installation of the keyboard/numeric pad assembly. Refer to Figure 6-23 during the procedure.

6.20.1 Keyboard/Numeric Pad Assembly Removal

1. Perform printer housing removal procedure (Paragraph 6.2.1).
2. Remove four (8-32) screws that secure keyboard to printer base.
3. To prevent scratching or damaging the keyboard, rest keyboard bezel on a piece of foam or bubble plastic. Turn keyboard bezel upside down and remove four (8-32) screws and washers that secure keyboard/numeric pad bezel.
4. Lift keyboard/numeric pad and disconnect cable connectors as required.

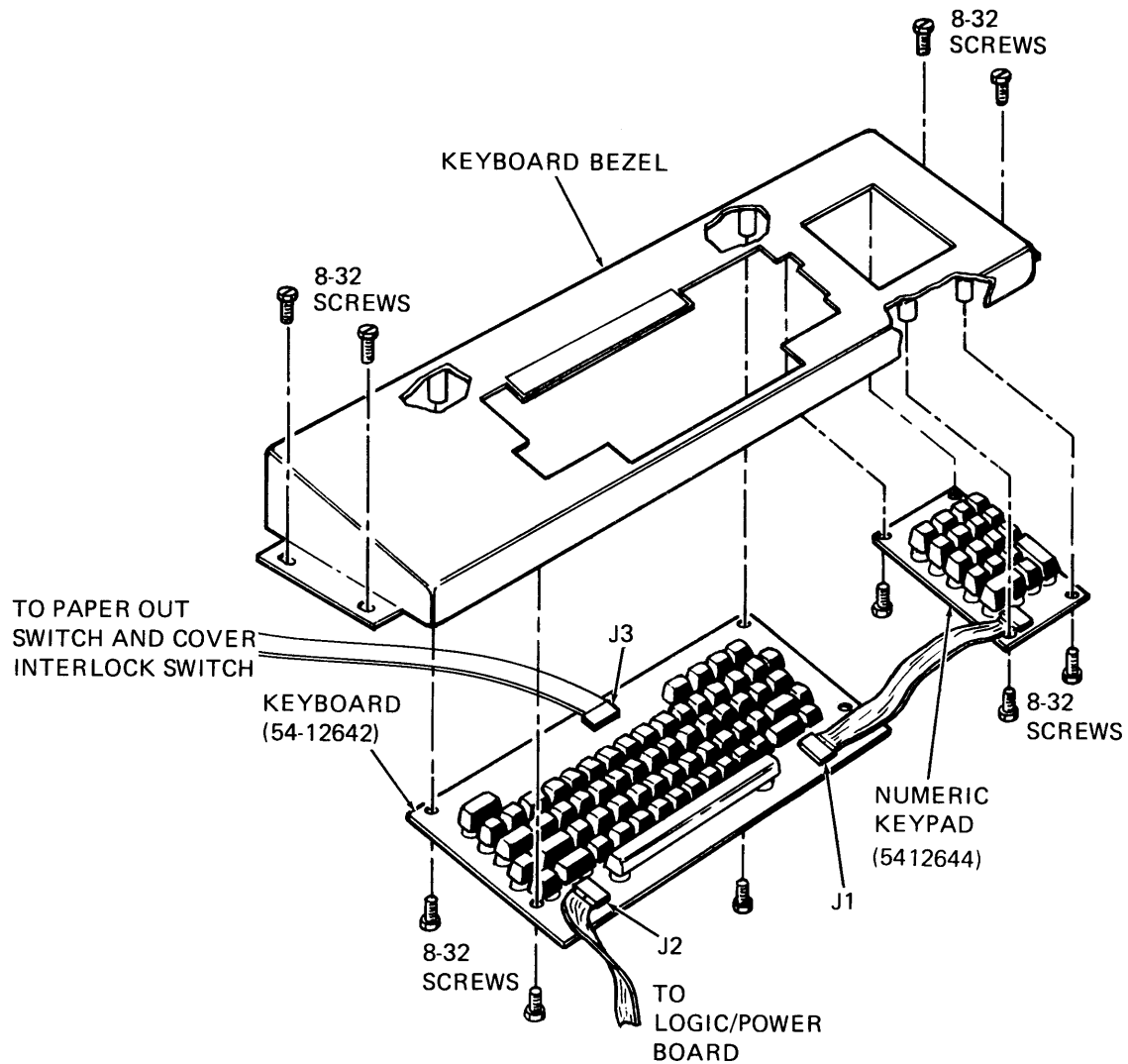

MA-2585A

Figure 6-23 Keyboard/Numeric Pad Removal and Installation

6.20.2 Keyboard/Numeric Pad Assembly Installation

1. Reconnect cable connectors to new keyboard/numeric pad. Place pad on bezel and secure with four (8-32) screws.

NOTE

The four-pin plug from the paper out switch and cover interlock switch can be inserted into J3 either way.

2. Replace keyboard bezel on cabinet base and secure by pressing in the two sides of bezel to engage the mounting slots.
3. Perform printer housing installation procedure (Paragraph 6.2.2).

6.21 POWER SUPPLY ASSEMBLY

The following procedures describe the removal and installation of the power supply. Refer to Figure 6-24 during the procedure.

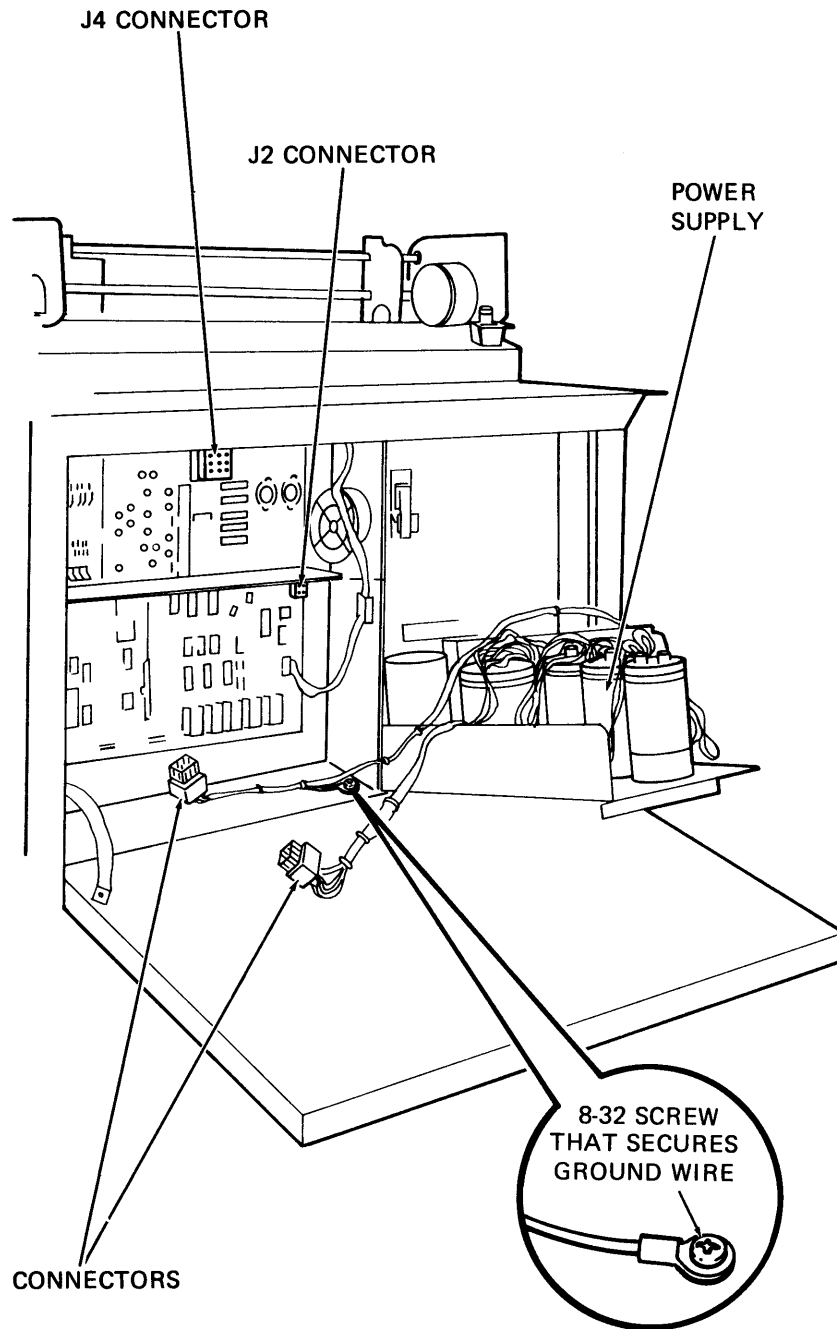

MA-2587

Figure 6-24 Power Supply Assembly Removal and Installation

6.21.1 Power Supply Assembly Removal

1. Remove ac power by unplugging LA120 power cord.
2. Open rear access door on cabinet.
3. Remove ground wire on the side of the power supply by removing (8-32) screw, lockwasher, and flat washer.
4. Disconnect connectors from J2 and J4 on logic/power board.
5. Loosen the two (8-32) screws at top of power supply, which will allow mounting plate to slide down.

CAUTION

Placing the full weight of the power supply on the door can damage the door.

6. Tilt power supply toward door and disconnect Mate-N-Lok™ connector from power entry bracket.
7. Carefully tilt out and remove the power supply.

™Mate-N-Lok is a trademark of AMP, Inc.

6.21.2 Power Supply Assembly Installation

CAUTION

Use care not to damage cables when installing power supply.

1. Connect power supply Mate-N-Lok connector to power entry bracket and slide power supply into position as shown in Figure 6-25.

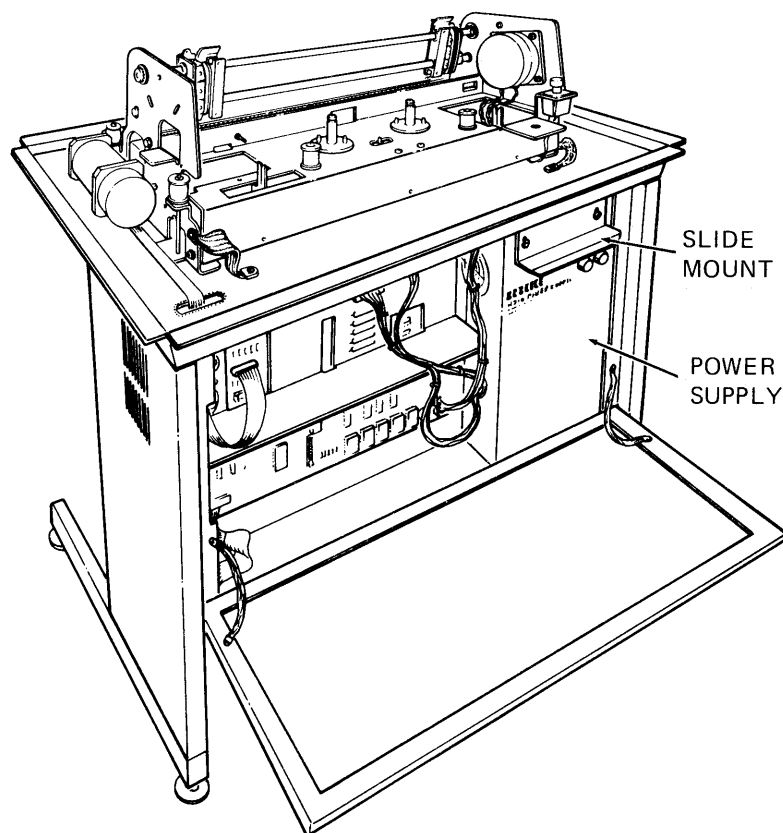

MA-2604

Figure 6-25 Power Supply Assembly in Position

2. Slide mounting plate into slot and tighten two (8-32) screws.
3. Reconnect connectors J2 and J4 to logic/power board.
4. Secure ground wire on the side of the power supply, by using 8-32 screw, lockwasher, and flat washer.
5. Close rear access door on cabinet.
6. Restore power to LA120.

6.22 PRINTER MECHANISM ASSEMBLY

The following procedure describes the removal and installation of the printer mechanism assembly.

6.22.1 Printer Mechanism Assembly Removal

1. Perform printer housing removal procedure (Paragraph 6.2.1).
2. Remove ribbon spools and ribbon.
3. Remove the four (6-32) screws, lockwashers, and flat washers that secure print head to carriage and set head aside (Figure 6-3).
4. Open rear access door.
5. Disconnect connectors from J3, J5, and J7 on logic/power board and clip necessary cable ties (Figure 5-1). Pull disconnected wires up through cabinet base.
6. Remove the two (8-32) screws fastening the two ground wires to cabinet base (Figure 6-26).
7. Remove speaker wires from speaker.
8. Loosen the two (8-32) screws on the power supply, thereby causing mounting plate to drop. Tilt power supply back to gain access to printer mechanism rear mounting screw. It is not necessary to completely remove power supply assembly.
9. Remove the two wires from cover interlock switch (Figures 6-27 and 6-21).
10. Remove the four (10-32) screws and washers that secure printer mechanism to cabinet base (Figure 6-26) using a 5/16 inch nut driver.
11. Carefully tilt printer mechanism up toward back of printer (Figure 6-26) and remove the two leads from the paper out switch (Figure 7-4).
12. Remove the two leads from the speaker and cut the cable ties holding the speaker leads.
13. Carefully remove printer mechanism.

6.22.2 Printer Mechanism Assembly Installation

1. Remove the two ground wires from old printer mechanism and connect them to new printer mechanism.
2. Place new printer mechanism on printer base and connect speaker, paper out, and cover interlock leads. Secure leads as required with cable ties. Secure wire harness to base using cable clamps.
3. Secure printer mechanism to base with four (10-32) screws and washers (Figure 6-26). Make screws finger tight.
4. Thread cables and wires down through slots at rear of cabinet.
5. Secure connectors to J3, J5, and J7 on logic/power board (Figure 5-1).

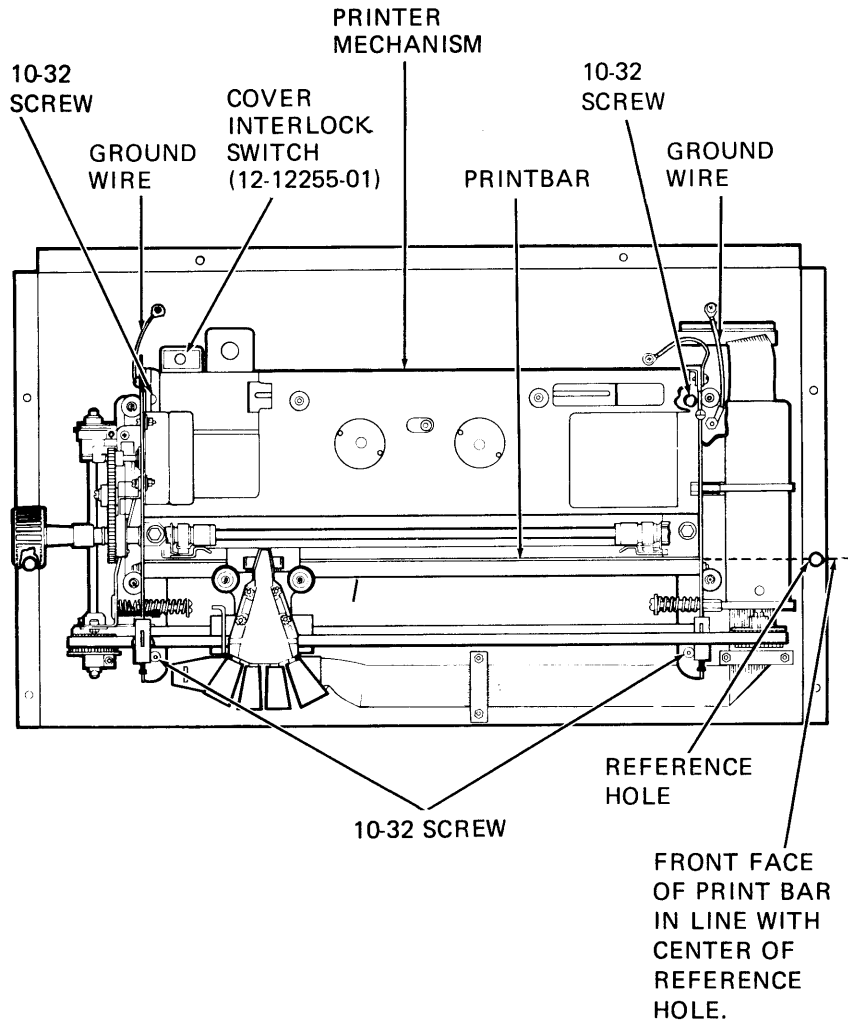

MA-2576

Figure 6-26 Printer Mechanism Assembly Removal and Installation

6. Connect ground wires from printer mechanism to base with 8-32 screws (Figure 6-26).
7. Dress cables and wires inside the cabinet and secure cable harness, as required, to cabinet using cable clamps.
8. Adjust position of printer mechanism (front to back) so that front surface of print bar coincides with centerline of the reference holes in cabinet (Figure 6-27) within 0.030 inch. Tighten the four (10-32) screws to 5 ± 1 in/lb of torque.
9. Perform print head installation procedure (Paragraph 6.3.2).
10. Slide print head assembly across carriage shafts and check to ensure that carriage assembly does not rub and is parallel to bent up flange (Figure 7-3). Loosen and readjust printer mechanism if necessary.

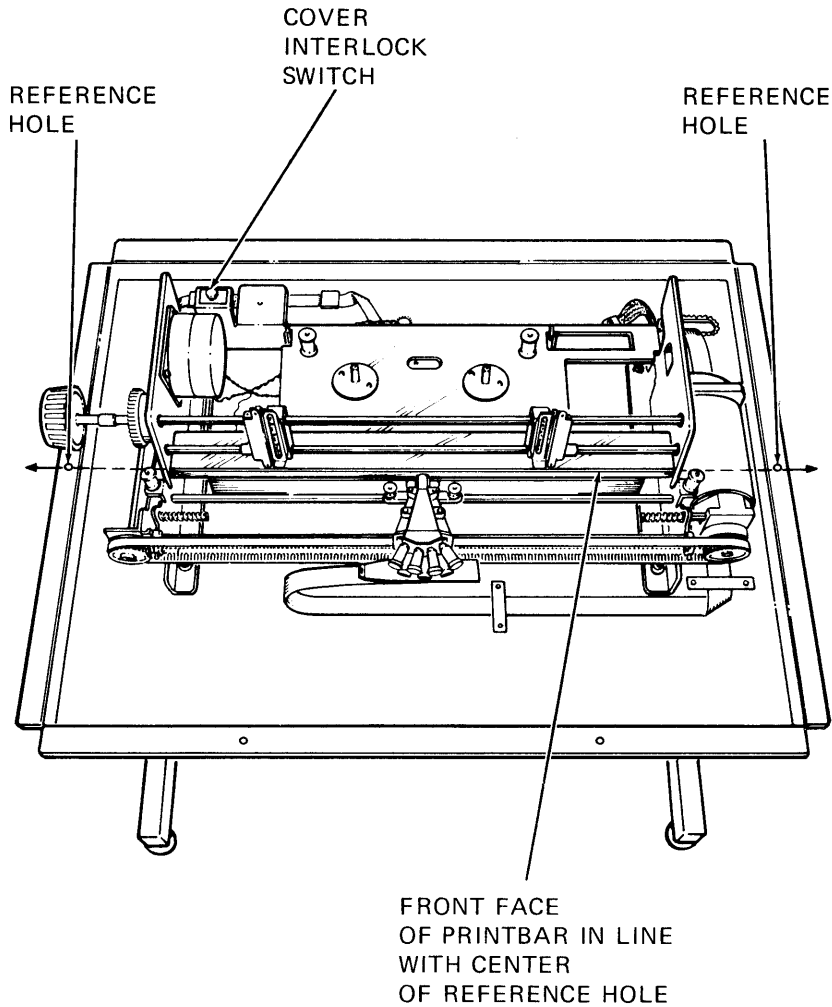

MA-2577

Figure 6-27 Cabinet Reference Holes

11. Carefully slide power supply back into position. Slide mounting plate through slot and tighten the two (8-32) screws.
12. Close rear access door on the cabinet.
13. Replace paper in printer but do not feed it up into tractors. Pull paper up through cabinet and printer mechanism to ensure that there is no drag on the paper. If drag is encountered, perform printer mechanism and paper guide adjustments (Paragraphs 7.2 and 7.3). Remove paper from machine.
14. Perform printer housing installation procedure (Paragraph 6.2.2).

6.23 CVT POWER SUPPLY MODULE

The following procedure describes the removal and installation of the CVT power supply module. Refer to Figure 6-28 during the procedure.

6.23.1 CVT Power Supply Module Removal

1. Remove ac power by unplugging LA120 power cord.
2. Perform power supply removal procedure (Paragraph 6.21.1).
3. Disconnect cables from J1 and J2 on the CVT power supply module.
4. Remove the three (6-32) screws that secure CVT power supply module to power supply.

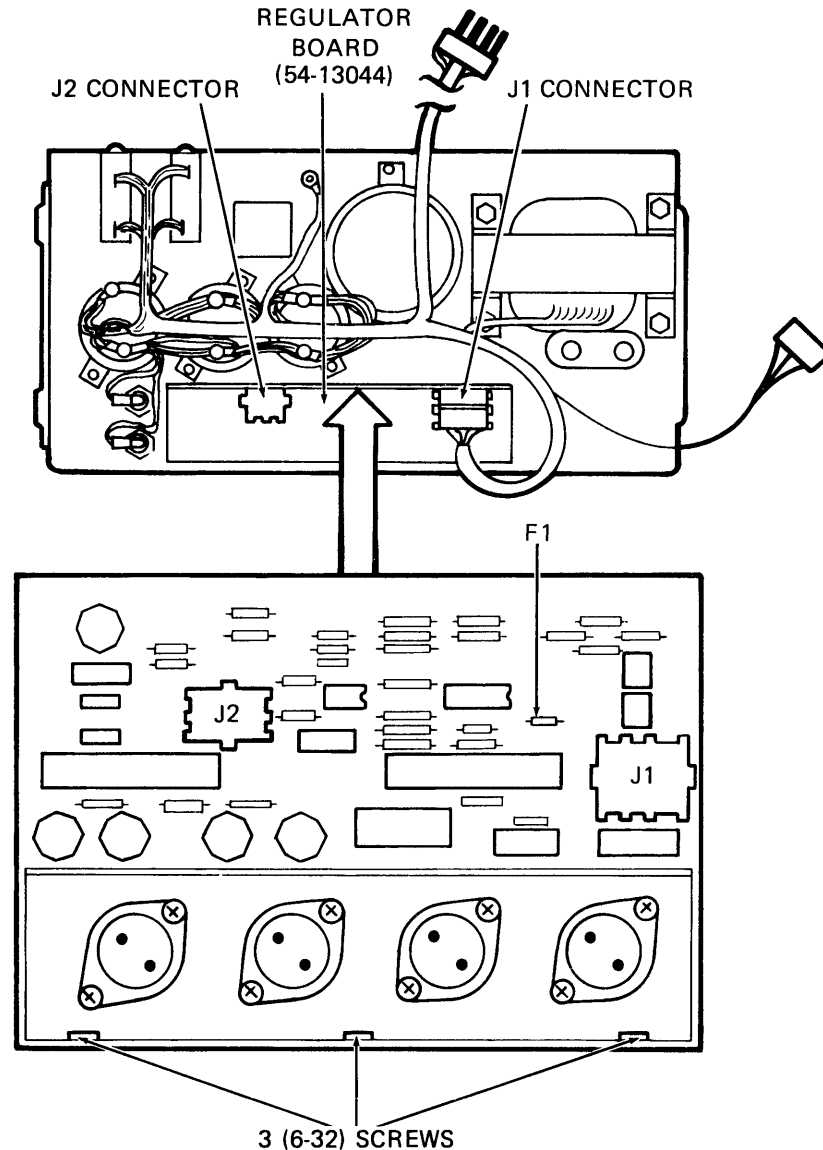

MA-2593

Figure 6-28 CVT Power Supply Module Removal and Installation

6.23.2 CVT Power Supply Module Installation

1. Secure new CVT power supply module to power supply using three (6-32) screws.
2. Reattach connectors to J1 and J2 of CVT power supply module.
3. Perform power supply installation procedure (Paragraph 6.21.2).
4. Restore power to LA120.

6.24 POWER ENTRY BRACKET ASSEMBLY

The following procedure describes the removal and installation of the power entry bracket assembly. Refer to Figure 6-29 during the procedure.

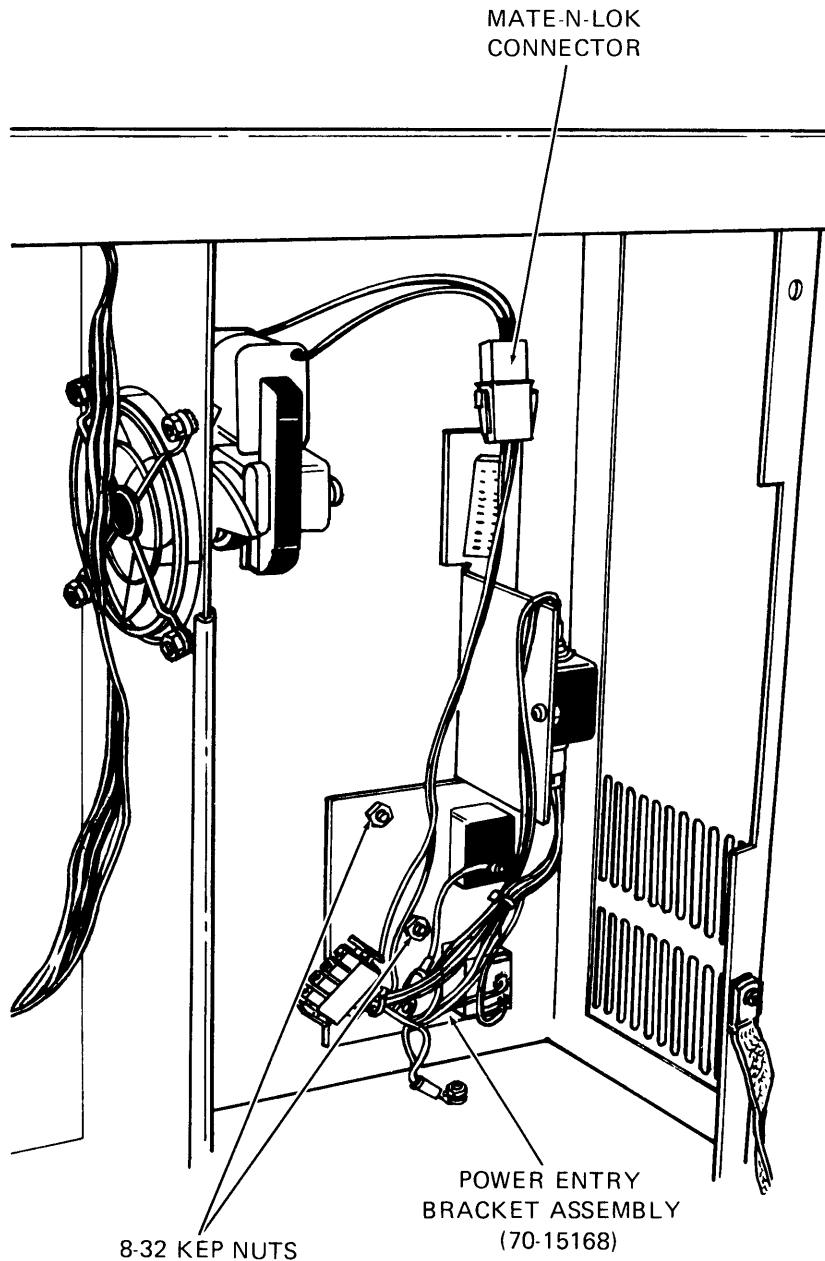

Figure 6-29 Power Entry Bracket Assembly Removal and Installation

6.24.1 Power Entry Bracket Assembly Removal

1. Remove ac power by unplugging LA120 power cord.
2. Unplug ac power cord from front of LA120 unit.
3. Open rear access door on cabinet.
4. Perform power supply removal procedure (Paragraph 6.21.1).
5. Disconnect Mate-N-Lok connector to fan.
6. Remove the three (8-32) nuts and captive washers.
7. Remove the one (8-32) screw, nut, and star washer securing ground wire to cabinet base.
8. Remove power entry bracket assembly.

6.24.2 Power Entry Bracket Assembly Installation

1. Mount power entry bracket assembly using three (8-32) nuts and captive washers.
2. Using the one (8-32) screw, nut, and star washer, secure ground wire to cabinet base; position wire adjacent to cabinet base metal frame.
3. Reconnect Mate-N-Lok connector to fan.
4. Perform power supply installation procedure (Paragraph 6.21.2).
5. Close rear access door on cabinet.
6. Reconnect ac cord.

6.25 FAN

The following procedure describes the removal and installation of the fan. Refer to Figure 6-30 during the procedure.

6.25.1 Fan Removal

1. Remove power by unplugging LA120 power cord.
2. Perform power supply removal procedures (Paragraph 6.21.1).
3. Remove the four (8-32) screws, lockwashers, and flat washers from fan mounting bracket.
4. Disconnect fan Mate-N-Lok and remove fan.

6.25.2 Fan Installation

1. Install fan using the four (8-32) screws, flat washers, and lockwashers. Fan must be installed with coil facing top of cabinet.
2. Connect fan Mate-N-Lok.
3. Place fan wires in cable clamp.
4. Perform power supply installation procedure (Paragraph 6.21.2).

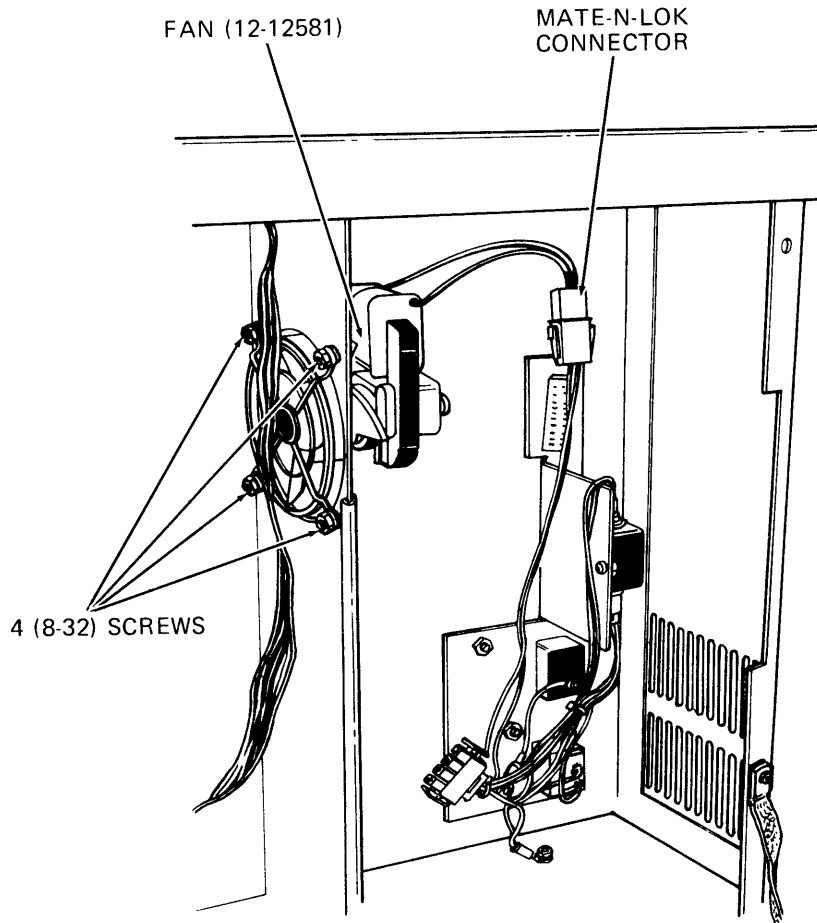

MA-2589

Figure 6-30 Fan Removal and Installation

6.26 LOGIC/POWER BOARD

The following procedure describes the removal and installation of the logic board.

6.26.1 Logic/Power Board Removal

1. Remove power by unplugging LA120 power cord. Remove printer paper.
2. Open rear access door on cabinet (Figure 6-31).
3. Disconnect all connectors from logic board (Figure 5-1).
4. Remove the seven (6-32) screws that secure the logic board to chassis. Remove by swinging right-hand side of board out first.

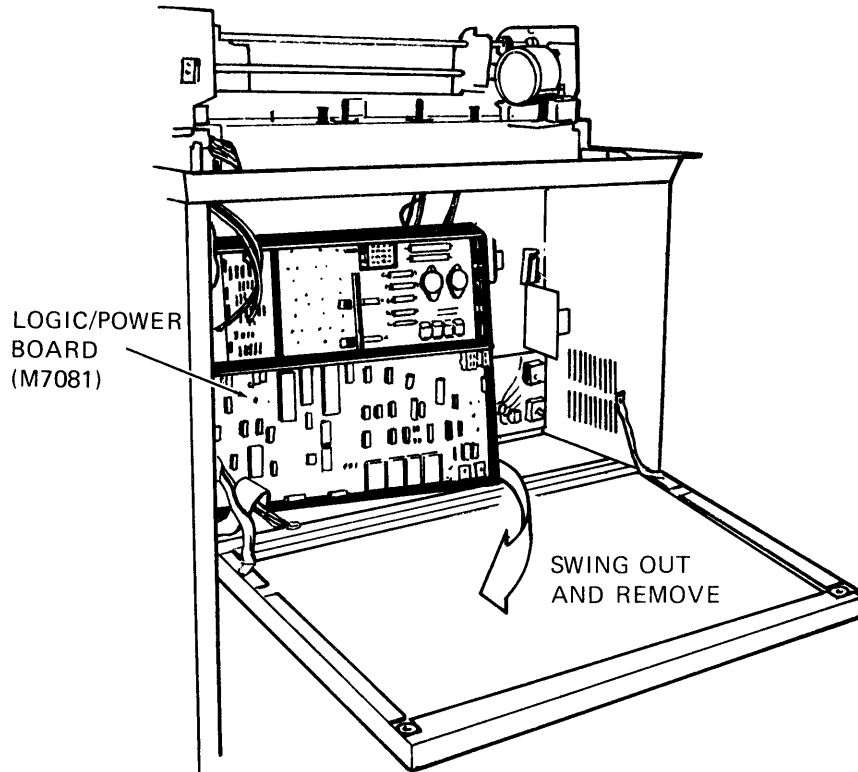

MA-2586

Figure 6-31 Logic/Power Board Removal and Installation

6.26.2 Logic/Power Board Installation

1. Place logic board on chassis (left-hand side first). Secure the board with seven (6-32) screws. Tighten to 8 ± 1 in/lb.

NOTE

The four (6-32) screws in the heat sink are 0.5 inch long, while the lower three (6-32) screws are 0.25 inch long.

2. Reconnect all connectors to logic/power board (Figure 5-1). Install connector J1 with beveled edge in upper left corner. Install connector J8 with red stripe on left. Install connectors J3 and J7 so they are centered on jack.

CAUTION

Be sure to follow the cable orientations in Step 2.

3. Close rear access door on cabinet.
4. Replace printer paper and restore power to LA120.