

THIRD PART

***Connection to PC Commodore,
Amiga and IBM Compatible***



**Printer
Initialisation**

PRINTER SWITCH-ON

Switch the printer on pressing the main ON/OFF switch on the part marked with "ON".

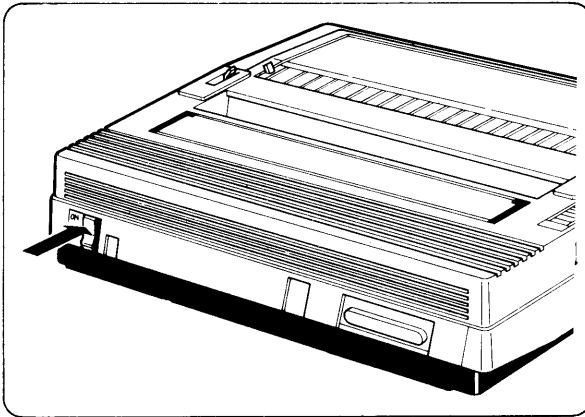

*Fig. 11-1
Switch in the ON
Position*

INITIALISATION

When the printer is turned on, the **ON** light indicator on the console lights up.

The printer performs the autodiagnosics (described in the chapter “Diagnostics”) and places the print head on the first column (physical left margin).

The Default settings, that is to say the settings selected during the latest programming procedure (see the chapter “Programming the machine settings), are stored. If the operator did not perform the programming procedure yet, the default factory settings, listed in the following paragraph, are stored instead.

If the paper is loaded, the printer is set **ON LINE**, ready to receive data from the connected host computer.

DEFAULT SETTINGS

The default factory settings for printer connection are listed below.

- Printer emulated = IBM Graphics Printer
- IBM PC mode (or compatible) printable character set = INTERNATIONAL 1
- Character definition = Draft (normal)
- Double pass print = monodirectional

- Horizontal spacing (print pitch) = 1/10" (2.54 mm)
- DLL for special character generation = enabled (see "Control Codes" chapter)
- Automatic CR = enabled (LF = LF + CR)
- Automatic LF = enabled (CR = CR)
- Out of paper indicator = enabled
- Vertical spacing = 1/6" (4.23 mm)
- Slashed zero = disabled
- DC1/DC3 dialogue procedure = disabled
- Form length = 12" (304.8 mm)
- Bottom of form (BOF) = 0
- Bidirectional BIM printing = disabled
- Proportional character spacing = disabled
- Character length = 8 bits
- Horizontal tab stops = a stop every eight characters.



Turning the printer off, data and settings issued by the host computers are lost.



The printer settings can be modified by the user by confirming or refusing via console a series of parameters that are printed when the SET-UP mode is entered.

OPERATING PROCEDURE

With the printer turned off (main ON/OFF switch in the OFF position), manually insert a sheet of paper on the printer (as described in Chapter 3 "Printer installation"). The sheet must be at least 210 mm wide and 400 mm long, and aligned slightly to the left of the first character position on the print line (to guarantee that all the information is printed on the page).



If the Sprocket device is installed, it must be removed before the programming procedure is performed.

Turn the printer on holding down simultaneously the **LINE FEED** and **FORM FEED** keys. The printer will be set in the programming mode (SET UP mode).

Fig. 12-1
Accessing the
Programming Mode
(SET UP)

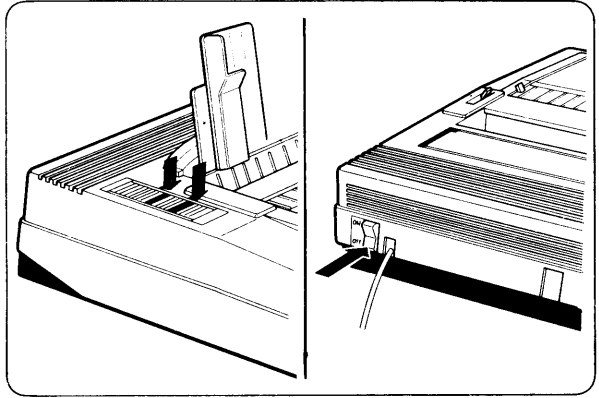

In this mode, the possible programming parameters will be automatically printed, one at a time; at each alternative the operator will respond pressing the **LINE FEED** key (= "YES") to confirm the proposed parameters, or the **FORM FEED** key (= "NO") to refuse it.

Never turn the printer off during the programming phase. If the printer is turned off accidentally or if a power failure occurs, the performed portion of the programming procedure will be cleared and replaced by the default setting (see "Default setting" in Chapter 6).

The programming procedure can be stopped at any time pressing the LOCAL key; it can also be completely cleared or confirmed by refusing or confirming the last proposed parameter. At this point the printer automatically exits the SET UP mode and is ready to receive data from the host computer.

EXAMPLE OF PRINTER PROGRAMMING

The operating procedure is better explained showing an example of programming.

TO CONFIRM PRESS LF, TO CHANGE PRESS FF, TO END PRESS LOCAL

```
INTERFACE
SERIAL COMMODORE          PARALLEL

PRINTER EMULATED IN PARALLEL AND SERIAL COMMODORE
IBM G. P.      EPSON FX 80      PROPRINTER

CHARACTER SET IN PARALLEL MODE
INTERNATIONAL 1 INTERNATIONAL 2 SPAIN      PORTUGAL      GREECE
ISRAEL

CHARACTER SET IN COMMODORE MODE
USA/UK DENMARK SWEDEN GERMANY FRANCE ITALY SWITZERLAND SPAIN

WOULD YOU LIKE TO STORE THESE PARAMETERS ?
YES      NO

NO CHANGES EXECUTED
```

Fig. 12-2 Example of Programming

The meaning of the messages shown in Figure 12-2 is as follows:

TO CONFIRM PRESS LF, TO CHANGE PRESS FF, TO END PRESS LOCAL

Press the LINE FEED switch to confirm, press the FORM FEED switch to refuse and press the LOCAL switch to end the programming phase.

INTERFACE = Interface type selection

PRINTER EMULATED IN PARALLEL AND SERIAL COMMODORE

Selection of printer to be emulated.

CHARACTER SET IN PARALLEL MODE

PC IBM (or compatible) printable character set.

CHARACTER SET IN COMMODORE MODE

Commodore printable character set.

WOULD YOU LIKE TO STORE THESE PARAMETERS?

Self-explanatory.

CHANGES EXECUTED

Self-explanatory.

To obtain the preceding example, perform the following:

Insert the paper and access the SET UP procedure as explained above. The following message is printed:

TO CONFIRM PRESS LF, TO CHANGE PRESS FF, TO END PRESS LOCAL

**INTERFACE
SERIAL COMMODORE**

Press the FORM FEED switch to refuse the proposed alternative, **SERIAL COMMODORE**. The last line of the message is thus modified:

**SERIAL COMMODORE
PARALLEL**

Press the LINE FEED switch to confirm the proposed alternative **PARALLEL** that selects the Centronics parallel interface.

A new message is printed:

**PRINTER EMULATED IN PARALLEL AND SERIAL COMMODORE
IBM G.P.**

Press the LINE FEED switch to confirm the proposed **IBM GRAPHICS PRINTER**.

A new message is printed:

**CHARACTER SET IN PARALLEL MODE
INTERNATIONAL 1**

Press the FORM FEED switch. The proposed **INTERNATIONAL 1** is refused and the last line of the message is changed as follows:

INTERNATIONAL 1 INTERNATIONAL 2

Press the FORM FEED switch. The proposed **INTERNATIONAL 2** is refused and the last line of the message is changed as follows:

INTERNATIONAL 1 INTERNATIONAL 2 SPAIN

Press the LINE FEED switch to confirm the proposed **SPAIN** that selects the "SPAIN" printable character set.

A new message is printed:

**CHARACTER SET IN COMMODORE MODE
USA/UK**

As no more changes are to be applied to the SET UP parameters, stop the programming phase pressing the LOCAL switch. The following message is printed:

**WOULD YOU LIKE TO STORE THESE PARAMETERS?
YES**

Press the LINE FEED switch to confirm the proposed YES that validates the selected settings:

- 1. INTERFACE: PARALLEL**
- 2. PRINTER EMULATED: IBM G.P.**
- 3. CHARACTER SET: SPAIN**

A new message is printed:

CHANGES EXECUTED

and the printer will automatically exit the SET UP phase.

Clearing the Settings

To clear completely the above settings, after the message:

WOULD YOU LIKE TO STORE THESE PARAMETERS?

YES

the operator should have pressed the FORM FEED switch; the last line would have become:

YES NO

At this point, pressing the LINE FEED switch, the selected alternative would have been **NO**, and the printer would have generated the following message:

NO CHANGES EXECUTED

and with the indication “NO PARAMETERS STORED“ the printer would have exited the SET UP phase.

AVAILABLE PARAMETER SETTINGS

The possible settings, shown in the following figure, are related to the emulated printer (IBM or Epson).

TO CONFIRM PRESS LF, TO CHANGE PRESS FF, TO END PRESS LOCAL

INTERFACE

SERIAL COMMODORE

PRINTER EMULATED IN PARALLEL AND SERIAL COMMODORE

IBM G. P. EPSON FX 80 PROPRINTER

CHARACTER SET IN PARALLEL MODE

INTERNATIONAL 1 INTERNATIONAL 2 SPAIN PORTUGAL GREECE

CHARACTER SET IN COMMODORE MODE

USA/UK DENMARK SWEDEN GERMANY FRANCE ITALY SWITZERLAND SPAIN USA/UK

OPEN MODE

5 COMMODORE COMMANDS 4 COMMODORE COMMANDS
4 P. C. COMMANDS 5 COMMODORE COMMANDS

AUTOMATIC SHEET FEEDER

NO YES

DOUBLE STRIKE PRINTING

MONODIRECTIONAL BIDIRECTIONAL

CHARACTER RESOLUTION

DRAFT N.L.Q.

CHARACTER SPACING

10 12 15 17.1 20 24

ENABLE D.L.L.

YES 2.5K BYTE L.B NO 5.5K BYTE L.B

LINE FEED *

LF=LF+CR LF = LF

CARRIAGE RETURN *

CR = CR CR=CR+LF

PAPER END DETECTION

YES NO

LINE SPACING *

1/6 7/72 1/8 1/6

SLASHED ZERO

NO YES

DC1/DC3 PROCEDURE *
NO YES

FORM LENGTH
12 11 10 9 8 7 6 5

SKIP OVER PERFORATION (BOF)
0 1/3 1/2 2/3 1 2 0

BIDIRECTIONAL B.I.M.
NO YES

PROPORTIONAL SPACING
NO YES

CHARACTER LENGTH *
8 BITS 7 BITS

WOULD YOU LIKE TO STORE THESE PARAMETERS ?
YES NO

NO CHANGES EXECUTED

Fig. 12-3 PC IBM (or compatible) Settings

When the SET UP phase is accessed, the printer generates a set of English messages, that have the following meanings:

TO CONFIRM PRESS LF, TO CHANGE PRESS FF, TO END PRESS LOCAL

Press the LINE FEED switch to confirm, press the FORM FEED switch to refuse and press the LOCAL switch to end the programming phase.

INTERFACE = Interface type selection:

- With the IBM/EPSON firmware, the interface to be selected is "Parallel" (Centronics).

PRINTER EMULATED IN PARALLEL AND SERIAL COMMODORE

Selection of printer to be emulated.

- The printers that can be emulated with IBM/EPSON firmware are the following three: EPSON FX 80, IBM "Graphics Printer" and IBM "Printer".

CHARACTER SET IN PARALLEL MODE

PC IBM (or compatible) printable character set:

- The emulated IBM character sets are the following six: International 1, International 2, Spain, Portugal, Greece and Israel.
- The emulated EPSON character sets are the following: USA, France, Germany/United Kingdom, Denmark/Sweden, Italy, Spain.

CHARACTER SET IN COMMODORE MODE

Commodore printable character set:

- As this selection is not significant for the IBM PC (or compatible) mode, confirm the first proposed alternative.

OPEN MODE

Address selection for Commodore or IBM PC (or compatible) commands through serial cable:

- As this alternative is not significant with the parallel interface connection, confirm the first proposed alternative.

DOUBLE STRIKE PRINTING

Self-explanatory.

- MONODIRECTIONAL
- BIDIRECTIONAL

CHARACTER RESOLUTION

Self-explanatory.

- DRAFT = Normal resolution.
- N.L.Q. = High definition.

CHARACTER SPACING

Print pitch (number of characters per inch):

- Selectable print pitches in IB/EPSON emulation are: 10, 12, 15, 17.1, 20, 24.

ENABLE D.L.L.

Down Line Loading enabling (special characters generated by users):

- Yes 2.5K Byte L.B = D.L.L. enabled and print buffer capacity reduced to 2.5K Byte.
- No 5.5K Byte L.B = D.L.L. disabled and print buffer full capacity equal to 5.5K Byte.

LINE FEED

Printer behaviour when receiving the LF command:

- LF = LF + CR Automatic carriage return at LF command reception.
- LF = LF No carriage return after the LF command.

CARRIAGE RETURN

Printer behaviour when receiving the CR command:

- CR = CR = Carriage return when receiving the CR command.
- CR = CR + LF = Carriage return and line feed when receiving the CR command.

PAPER END DETECTION

Self-explanatory.

- This selection can be enabled (YES) or disabled (NO); in the latter case, the complete sheet can be printed down to the last line, but special care must be applied to avoid printing on the printer platen.

LINE SPACING

Vertical spacing (line feed width, in inches):

- The following vertical spacings can be selected: 1/6" (4.23 mm), 7/72" (2.47 mm), 1/8" (3.175 mm).

SLASHED ZERO

Self-explanatory. Options available (YES) or (NO).

DC1/DC3 PROCEDURE

DC1/DC3 dialogue:

- This dialogue can be enabled (YES) or disabled (NO); see the DC1, DC3 and ESCQ 3 control codes below.

FORM LENGTH

Self-explanatory:

- The following form lengths are selectable in IBM/EPSON emulation: 5, 6, 7, 8,9, 10, 11 and 12".

SKIP OVER PERFORATION (BOF)

Bottom of form (in inches):

- The following widths are selectable for the bottom of form: 0, 1/3, 1/2, 2/3, 1 and 2 inches.

BIDIRECTIONAL B.I.M.

Bidirectional Graphics Printing:

- It can be enabled (YES) or disabled (NO); in the latter case the monodirectional graphics printing is enabled.

PROPORTIONAL SPACING

Proportional print pitch:

- It can be enabled (YES) or disabled (NO).

CHARACTER LENGHT

Data bit number issued to the printer:

- This value can be 8 or 7 bits.

WOULD YOU LIKE TO STORE THESE PARAMETERS?

Self-explanatory.

CHANGES EXECUTED

Self-explanatory.

**Connection to the
Host Computer**

The connection of the printer to the Computer is performed through a cable, normally provided with the computer itself.

The printer interface is a STANDARD parallel interface; the interface of the computer to be connected must be of the same type to guarantee a proper dialogue. Insert the cable (male) connector in the printer (female) connector and lock it by means of the side springs.

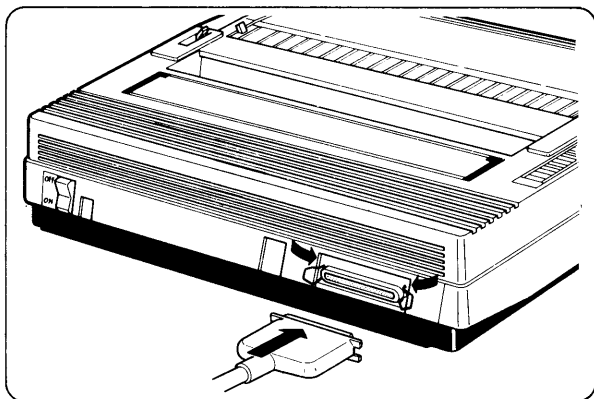

*Fig. 13-1
Connection to
Host Computer*

The maximum advised length of the connection cable is 3 meters.

For any problems that could arise, contact your dealer or the Field Engineering organization.

The printer can now be driven by the host computer by means of the control codes.

CONTROL CODES

The printer receives bytes (sets composed of 8 bits) from the host computer. Some of these bytes are printable characters, others are control codes (settings and commands).

The correspondance between bytes, printable characters and some of the control codes is included in Chapter 16 "Characters and Codes Tables". To each byte corresponds an ASCII character, that in its turn corresponds to a decimal or hexadecimal code.

Example:

To byte 01000001 corresponds the ASCII character "A", that in its turn corresponds to the decimal code "65" or to the hexadecimal code "41".

In the following sections, the used notation is therefore:

01000001 A = 65D = 41H.

Apart from the control codes, Chapters 14 and 15 "IBM Proprinter Compatible Control Codes" and "IBM G.P. and EPSON FX 80 Compatible Control Codes", describes the codes composed of the ESC characters (27D or 1BH), called "Escape Sequences".

The printer can also operate in graphics mode; in this case, dots and not an ASCII character correspond to each byte (see the subsequent section "GRAPHICS PRINT" in this manual).

The printer can be compatible with the two IBM "G.P." and "PROPRINTER" and the EPSON FX 80 printer.

The two following chapters describe the control code functions that allow the above mentioned compatibility.

IBM PROPRINTER EMULATION

The control codes are grouped according to the performed functions, as follows:

- Graphics layout
- Vertical spacing setting
- Paper feed
- Format control
- Miscellaneous
- Graphics printing
- Down Line Loading (DLL) of special characters
- Extended table characters printout.



The symbol “n” (or “n₁”, etc.) used in some places, is referred to the character whose decimal code is n (n₁, etc.).

Graphics Layout

- ESC G Sets the “NLQ” print mode. Printing is performed in two passes: after the first pass, the paper is fed of one elementary vertical spacing (1/216”).
- LPRINT CHR\$(27);CHR\$(71);
or
LPRINT CHR\$(27);“G”;
- ESC H Clears the “NLQ” print mode, restoring the normal print mode.
- LPRINT CHR\$(27);CHR\$(72);
or
LPRINT CHR\$(27);“H”;
- ESC I n Selects the print definition according to parameter n:
n=0 Draft print definition and normal characters
n=2 High print definition (NLQ) and normal characters
n=4 Normal print definition and special characters generated by Down Line Loading (DLL) by means of the ESC = control code
n=6 High print definition (NLQ) and special characters generated by DLL
- LPRINT CHR\$(27);CHR\$(73);CHR\$(n);
- SO Sets the “Double Width” print mode for a whole line. The character is printed at a spacing double of the current, so that the number of characters per inch is halved. Each character occupies two tab stops. It is cleared by CR, CAN, LF or DC4.
- LPRINT CHR\$(14);
- DC4 Clears the “Double Width” print mode set by the SO commands and restore the printer to the previous spacing.
- ESC W 1 Sets the “Double Width” print mode. The setting stays valid up to the reception of code ESC W 0.
- LPRINT CHR\$(27);CHR\$(87);CHR\$(49);
or
LPRINT CHR\$(27);“W”;

- ESC W 0 Clears the “Double Width“ print mode set by ESC W 1.
LPRINT CHR\$(27);CHR\$(87);CHR\$(48);
or
LPRINT CHR\$(27);“W“;CHR\$(48);
- SI Sets the “Condensed“ print mode with a 17.1 chars/inch spacing.
It is cleared by DC2 after the printer restarts printing with the horizontal spacing selected during the machine setting phase.
LPRINT CHR\$(15);
- DC2 Clears the “Condensed“ print mode set by SI and also the 12 cpi-print mode; it restores printing at the horizontal spacing selected during the machine setting phase.
LPRINT CHR\$(18);
- ESC - 1 Sets the “Underline“ print mode for all characters and blanks following the command. It is cleared by ESC - 0.
LPRINT CHR\$(27);CHR\$(45);CHR\$(49);
or
LPRINT CHR\$(27);“-“;CHR\$(49);
- ESC - SOH Same function as ESC - 1.
LPRINT CHR\$(27);CHR\$(45);CHR\$(1);
- ESC - 0 Clears the “Underline“ print mode.
LPRINT CHR\$(27);CHR\$(45);CHR\$(48);
- ESC - NUL Same function as ESC - 0.
LPRINT CHR\$(27);CHR\$(45);CHR\$(0);

- ESC _ 1 Sets the “Overline“ print mode for all characters and blanks following the command. It is cleared by ESC _ 0.
- ```
LPRINT CHR$(27);CHR$(95);CHR$(49);
or
LPRINT CHR$(27);“ _ “;CHR$(49);
```
- ESC \_ SOH Same function as ESC \_ 1.
- ```
LPRINT CHR$(27);CHR$(95);CHR$(1);
```
- ESC _ 0 Clears the “Overline“ print mode.
- ```
LPRINT CHR$(27);CHR$(95);CHR$(48);
```
- ESC \_ NUL Same function as ESC \_ 0.
- ```
LPRINT CHR$(27);CHR$(95);CHR$(0);
```
- ESC E Sets the “Emphasized“ print mode. Characters are printed twice and printing is performed at half speed.
- ```
LPRINT CHR$(27);CHR$(69);
or
LPRINT CHR$(27);“E“;
```
- ESC F Clears the “Emphasized“ print mode set by ESC E.
- ```
LPRINT CHR$(27);CHR$(70);  
or  
LPRINT CHR$(27);“F“;
```
- ESC S 0 Sets the “Superscript“ print mode. Characters are half height with respect to normal printing and are printed in the upper half line.
- ```
LPRINT CHR$(27);CHR$(83);CHR$(48);
or
LPRINT CHR$(27);“S“;CHR$(48);
```

ESC S 1      Sets the "Subscript" print mode. Characters are half height with respect to normal printing and are printed in the lower half line.

LPRINT CHR\$(27);CHR\$(83);CHR\$(49);  
or  
LPRINT CHR\$(27);"S";CHR\$(49);

ESC T      Clears the "Subscript" and "Superscript" print modes. If the printer had not been preset for these print modes, the command is ignored.

LPRINT CHR\$(27);CHR\$(84);  
or  
LPRINT CHR\$(27);"T";

ESC :      Sets the print pitch at 12 chars/inch. This setting is cleared by the DC2 code that restores the horizontal spacing selected during the machine setting phase.

LPRINT CHR\$(27);CHR\$(58);  
or  
LPRINT CHR\$(27);":";

### Vertical Spacing Setting

ESC 0      Sets the vertical spacing at 1/8" (3.175 mm).

LPRINT CHR\$(27);CHR\$(48);  
or  
LPRINT CHR\$(27);"0";

ESC 1      Sets the vertical spacing at 7/72" (2.47 mm).

LPRINT CHR\$(27);CHR\$(49);  
or  
LPRINT CHR\$(27);"1";

ESC 2      It is the executive command for ESC A. If not preceded by ESCA, sets the vertical spacing at 1/6" (4.23 mm).

LPRINT CHR\$(27);CHR\$(50);  
or  
LPRINT CHR\$(27);"2";

ESC 3 n Sets the vertical spacing at  $n/216''$  ( $0.1176 \times n$  mm). To move exactly of  $n/216''$ , the "n" value must be a multiple of 3, in the range 1-255.

For BIM 8-bit printing, set a vertical spacing of  $24/216''$ .

```
LPRINT CHR$(27);CHR$(51);CHR$(1-255);
```

or

```
LPRINT CHR$(27);"3";CHR$(1-255);
```

ESC A n Sets the vertical spacing at  $n/72''$  ( $0.3528 \times n$  mm). ESC 2 is the executive command of ESC A and starts the new vertical spacing.  
ESC 2  
(see above)

The value "n" can be any number in the range 1-85 (from  $1/72$  to  $85/72$ ). If  $n = 0$ , the previous spacing set by ESC A remains valid. The default value is 6 lines per inch ( $12/72$ ). Ex: to set a vertical spacing of 8.47 mm, ( $24/72''$ ), use the ESC A 24 code.

```
LPRINT CHR$(27);CHR$(65);CHR$(1-85);
```

or

```
LPRINT CHR$(27);"A";CHR$(1-85);
```

## Paper Feed

LF Causes the printout of the buffer and advances the paper of one vertical spacing. The vertical spacing width is the programmed one. In case less than one vertical spacing was left on the paper, the printer will advance the paper up to the first line of the following page (Top of Form).

```
LPRINT CHR$(10);
```

**FF** Causes the printout of the buffer and advances the paper to the first line of the following page (Top of Form). The command must be sent within the printable field, otherwise (if sent in the BOF field), the printer will not supply a new sheet and will be set in the LOCAL status, as the end-of-paper is detected before the FF command.

LPRINT CHR\$(12);

### **Horizontal and Vertical Format Control**

**BS** Causes the printout of the buffer and the movement of the print head of one character pitch, or two (if set for the "Double Width" mode), to the left. The selected horizontal spacing defines the print head movement. This code is used to reprint a character.

LPRINT CHR\$(8);

**HT** Moves the print head onto the next horizontal tab stop programmed by means of ESC D. The printing of the subsequent characters starts at this point of the line. At power on, the stops are located at 8 columns from each other, starting at column 9.

LPRINT CHR\$(9);

ESC D  $n_1$       Sets up to 30 horizontal tab stops ( $k = 30$ ). Parameters  $n_1 \dots n_k$   
 $n_2 \dots$       must be issued in ascending order, and indicate the number of  
 $n_k$  NUL      columns with the tab stops (the first print column to the left is  
                 column 0). The stops can be preset starting from number 1. At  
                 power on, the stops are located at a distance of 8 columns from  
                 each other.

ESC D  $n_1$ :      LPRINT CHR\$(27);CHR\$(68);CHR\$(1-254);  
 $n_2 \dots$ :      LPRINT CHR\$(1-254);..  
 $n_k$  NUL: LPRINT CHR\$(1-254);"0";

VT                Advances the module up to the next vertical tab stop. If the next  
                 vertical tab stop exceeds the form length, this command causes  
                 the paper to advance of one vertical spacing. If no vertical tab  
                 stops have been set, (or at power on), this command causes the  
                 buffer to be printed out, and advances the paper of one vertical  
                 spacing, like the LF code.

LPRINT CHR\$(11);

ESC B  $n_1$       Sets up to 64 vertical tab stops ( $k = 64$ ). Parameters  $n_1 \dots n_k$  must  
 $n_2 \dots$       be issued in ascending order, and indicate the number of the form  
 $n_k$  NUL      row with the tab stops (the first form line has  $n_1 = 1$ ). At power  
                 on, no vertical stops are present.

The programmed stops are cleared issuing the code "ESC R" or  
"ESC B NUL". If no stops have been programmed, this com-  
mand advances the paper of one vertical spacing, like the LF code.

ESC B  $n_1$ :      LPRINT CHR\$(27);CHR\$(66);CHR\$(1-254);  
 $n_2 \dots$ :      LPRINT CHR\$(1-254);..  
 $n_k$  NUL: LPRINT CHR\$(1-254);"0";

ESC R Clears all the tab stops:  
- the horizontal tab stops set by code ESC D, restoring the default condition: one stop each 8 columns;  
- the vertical tab stops set by code ESC B.

```
LPRINT CHR$(27);CHR$(82);
or
LPRINT CHR$(27);"R";
```

ESC C n Sets the form length in number of vertical spacings (lines); the vertical spacing value is the one previously selected.

```
LPRINT CHR$(27);CHR$(67);CHR$(1-127);
or
LPRINT CHR$(27);"C";CHR$(1-127);
```

ESC C  
NUL n Sets the form length in number of inches (from 1 to 22). At power up, the form length is the one selected during the initial programming phase.

ESC 4 Sets the current position as first print line within the form length.

```
LPRINT CHR$(27);CHR$(52);
or
LPRINT CHR$(27);"4";
```

ESC N n Sets the number of "n" spacings at the bottom of form that must not be used for printing and are to be automatically skipped (BOF = Bottom of Form).

```
LPRINT CHR$(27);CHR$(78);CHR$(1-127);
or
LPRINT CHR$(27);"N";CHR$(1-127);
```



**The paper must be properly positioned at the beginning of form otherwise this command will not be executed correctly.**

**The command will have to be reissued in case the page length is modified by means of the ESC c sequence.**

ESC O Clears the bottom of form (BOF).

LPRINT CHR\$(27);CHR\$(79);  
or  
LPRINT CHR\$(27);"O";

### Miscellaneous

NUL Zero (non operative command). Used with ESC D to closed the parameter list, or with other codes to define a possible selection (see, for instance, the codes ESC S NUL and ESC - NUL).

LPRINT CHR\$(0);

BEL Command acknowledged by the printer, but not operative.

LPRINT CHR\$(7);

CR Causes the printout of the buffer and takes the printhead carriage at the first column of the same line.

In the initial programming of the printer, performed by the operator, it is possible to select a paper feed of one vertical spacing: CR + LF (see the chapter "Programming the Machine Setting).

LPRINT CHR\$(13);

DC1 If, during the initial printer programming phase, the DC1/DC3 dialogue procedure had been selected, this code sets the printer for receiving data from the host computer.

LPRINT CHR\$(17);

ESC Q 3 If, during the initial printer programming phase, the DC1/DC3 dialogue procedure had been selected, this code deselects the printer that does not receive any more data from the host computer.

LPRINT CHR\$(27);CHR\$(81);CHR\$(3);  
or  
LPRINT CHR\$(27);"Q";CHR\$(3);

- DC3 This code is ignored by the printer.
- SP Causes the print position to advance one pitch of the current character.  
LPRINT CHR\$(32);
- CAN Clears the contents of the print buffer (data contained in the buffer are lost) without changing the current print position and clears the eventual print setting for "Double Width" selected by SO or ESC SO.  
LPRINT CHR\$(24);
- ESC 5 n n=1 Automatic LF is preset after CR (CR = CR + LF);  
n=0 This presetting is cleared, therefore CR = CR.  
The request sent by the code clears any opposite settings selected during the initial printer programming phase.  
LPRINT CHR\$(27);CHR\$(53);CHR\$(0-1);
- ESC 6 Selects Character Table 2 (see Appendix). This table contains characters and symbols in languages different from English.  
LPRINT CHR\$(27);CHR\$(54);  
or  
LPRINT CHR\$(27);"6";
- ESC 7 Selects Character Table 1 (see Appendix). This table contains characters and symbols normally used in the English language.

ESC J n Sets the vertical spacing at  $n/216''$  (0.1176xn mm). To move exactly of  $n/216''$ , the "n" value must be a multiple of 3, in the range 1-255.

For BIM 8-bit printing, set a vertical spacing of  $24/216''$ .

```
LPRINT CHR$(27);CHR$(74);CHR$(1-255);
or
LPRINT CHR$(27);"J";CHR$(1-255);
```

ESC U n n = 1 Sets monodirectional printing;  
n = 0 Restores bidirectional printing.

Monodirectional printing allows to improve quality and vertical alignment of printed characters.

```
LPRINT CHR$(27);CHR$(85);CHR$(0-1);
or
LPRINT CHR$(27);"U";CHR$(0-1);
```

### Graphics Printing

The printer can operate in graphics mode according to the Bit Image Mode (BIM). In this mode, the printing is performed with dots in horizontal strips 8 dots high. A dot is printed if the corresponding bit in the received byte is at logic 1. If the corresponding bit is at logic 0, the dot is not printed.

Fig. 14-1  
Correspondance between Bits and Print Head Needles

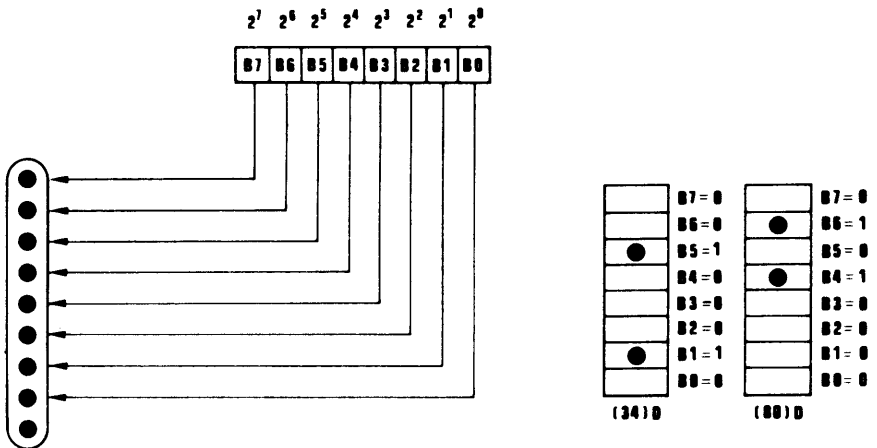

On the same line, alphanumeric characters and BIM data can be printed. The graphics features are obtained by means of the four commands listed below.

ESC K            Sets the BIM graphics printing with horizontal density of 60  
 $n_1$   $n_2$  data    dots/inch. Parameters  $n_1$  and  $n_2$  indicate the number of BIM data  
 that follow. To obtain  $n_1$  and  $n_2$  values, operate as for the following  
 example.

$$n_2 = \text{INTEGRAL quotient obtained dividing the data number by 256}$$

$$n_1 = \text{Data number} - (n_2 \times 256)$$

Ex.: To print 263 data:

$$n_2 = 1 \text{ (263/256 = 1.02734375; the INTEGRAL number is therefore 1)}$$

$$n_1 = 263 - (1 \times 256) = 7$$

The maximum number of BIM data printable on one line is 480. If  $n_1$  and  $n_2$  define a number of data that exceed the limit, the exceeding part is ignored.

If on a line, alphanumeric characters are also printed, the maximum number of BIM data decreases as by the following table.

| PRINT PITCH  |                 | BIM COLUMNS PER CHARACTER |
|--------------|-----------------|---------------------------|
| PICA         | 10 CHARS/INCH   | 6                         |
| ELITE        | 12 CHARS/INCH   | 5                         |
| CONDENSED    | 17.1 CHARS/INCH | 3.5                       |
| DOUBLE WIDTH |                 |                           |
| PICA         | 5 CHARS/INCH    | 12                        |
| DOUBLE WIDTH |                 |                           |
| CONDENSED    | 8.5 CHARS/INCH  | 7                         |
| DOUBLE WIDTH |                 |                           |
| ELITE        | 6 CHARS/INCH    | 10                        |

ESC K:            LPRINT CHR\$(27);CHR\$(75);  
 $n_1$   $n_2$  Data:    LPRINT CHR\$( $n_1$ );CHR\$( $n_2$ );Data

ESC L            Sets the BIM graphics printing with horizontal density of 120  
n<sub>1</sub> n<sub>2</sub> data    dots/inch. The maximum number of BIM data per row is 960. For  
the other features, the same rules as ESC K apply.

ESC L:            LPRINT CHR\$(27);CHR\$(76);  
n<sub>1</sub> n<sub>2</sub> Data:    LPRINT CHR\$(n<sub>1</sub>);CHR\$(n<sub>2</sub>);Data

ESC Y            Sets the BIM graphics printing with horizontal density of 120  
n<sub>1</sub> n<sub>2</sub> data    dots/inch, with a double print speed. The maximum number of BIM  
data per row is 960, but adjacent horizontal dots are not printed.  
For the other features, the same rules as ESC K apply.

ESC Y:            LPRINT CHR\$(27);CHR\$(89);  
n<sub>1</sub> n<sub>2</sub> Data:    LPRINT CHR\$(n<sub>1</sub>);CHR\$(n<sub>2</sub>);Data

ESC Z            Sets the BIM graphics printing with horizontal density of 240  
n<sub>1</sub> n<sub>2</sub> data    dots/inch. The maximum number of BIM data per row is 1920 by-  
te, but adjacent horizontal dots are not printed. For the other fea-  
tures, the same rules as ESC K apply.

ESC Z:            LPRINT CHR\$(27);CHR\$(90);  
n<sub>1</sub> n<sub>2</sub> Data:    LPRINT CHR\$(n<sub>1</sub>);CHR\$(n<sub>2</sub>);Data

### Down Line Loading of Special Characters

The user can create from 1 to 94 personalized characters; these charcters can be printed in the place of the normal characters.

The down line loading of the special characters (DLL = Down Line Loading) in the printer memory is performed thurgh the ESC = code. If less than 94 characters are loaded, all the character codes must be in sequence, starting from the first code.



**Turning off the printer, the stored characters are lost.**

**ESC =** This code must be followed by the parameters **m n c a p<sub>1</sub> p<sub>2</sub>...p<sub>11</sub>**, that are the decimal codes of variable bytes according to the characters to be loaded. Each ESC = command can load a maximum of 256 subsequent characters.

**LPRINT CHR\$(27);CHR\$(61);parameters**

The parameters meaning is as follows:

**m and n** Specify the total number of characters to be loaded in the printer memory.

1. To compute the number of characters to be loaded (t), use the following formula:  
 $t = (\text{number of characters} \times 13) + 2$
2. If the number of characters to be loaded is less than 256,  $m = t$  and  $n = 0$

Example: For two characters:

$$t = (2 \times 13) + 2 = 28$$

$$m = 28$$

$$n = 0$$

3. If the number of characters to be loaded is greater than 256,  $m = \text{module}$  and  $n = \text{integral quotient}$ .

Example: For 94 characters:

$$t = (94 \times 13) + 2 = 1224$$

$$1224/256 = 4$$

$$m = 200 \text{ (module obtained dividing 1224 by 256)}$$

$$n = 4 \text{ (quotient of division 1224 by 256).}$$

**c** This is the decimal code of the first character to be loaded. Standard characters will be replaced by the personalized characters starting from this point.

Example: A character set is to be loaded to replace the characters starting from the upper case "A" letter:

$c = 65$  (ASCII decimal code for letter A)

Characters can be loaded starting from decimal code 33 up to 126 included. Characters to be loaded must be subsequent starting from code "c".

**a** This parameter indicates if the character is ascending or descending:

If  $a = 0$  printing is performed with the first 8 needles of the print head (the ninth needle, the lowest one, towards the bottom of the character, is not used).

If  $a = 1$  printing is performed with the last 8 needles of the print head (the first needle, the upper one, towards the top of the character, is not used).

**P<sub>1</sub>, P<sub>2</sub>...P<sub>11</sub>** These are the values of the vertical columns of dots in each character.



Use the "ESC I" command, previously explained in the section "Graphics Layout" in this chapter, to print characters in Draft or N.L.Q. mode.

### Example of Symbol Loading

This example illustrates the replacement of the symbol "@" with the Copyright symbol "©", using the first 8 needles of the print head ( $a = 0$ ). The computation of  $m$  and  $n$  is performed as follows:

$$t = (1 \times 13) + 2 = 15$$

$$m = 15$$

$$n = 0$$

$$c = \text{CHR}\$(64)$$

$$a = \text{CHR}\$(0)$$

The values to be issued to the printer are the following:

```
LPRINT CHR$(27);CHR$(61);CHR$(15);
CHR$(0);CHR$(20);CHR$(64);
CHR$(0);CHR$(0);CHR$(60);CHR$(66);
CHR$(0);CHR$(153);CHR$(165);
CHR$(165);CHR$(165);CHR$(129);
CHR$(0);CHR$(66);CHR$(60);
```

As shown in this example, character “©” has been loaded in the printer.

Data remain in the portion of memory dedicated to personalized characters until:

- the printer is turned off, or
- these data are overwritten by different data, or
- the following message is issued to the printer to clear the personalized data buffer:

```
LPRINT CHR$(27);CHR$(61);CHR$(0);CHR$(0);
```

To draw every character, the user is provided of the following  $8 \times 11$  effective matrix:

*Fig. 14-2 Print Matrix*

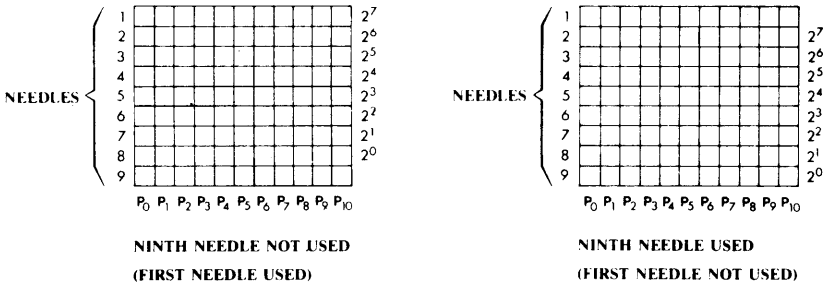

The dot is printed if the corresponding bit in the received Byte “p” is 1.

On the  $8 \times 11$  matrix, the user can mark the print dots required to draw the character, keeping in mind that, to guarantee the recycle of the print head, a needle activated in column "n" cannot be re-activated in column "n + 1". If the configuration sent to the printer does not comply with this rule, the printer automatically makes the configuration acceptable. In this case, however, the issued character will differ from the printed character for all the dots that would inhibit needle recycle, had they been printed.

*Fig. 14-3*  
*Example of Personalized Character Definition*

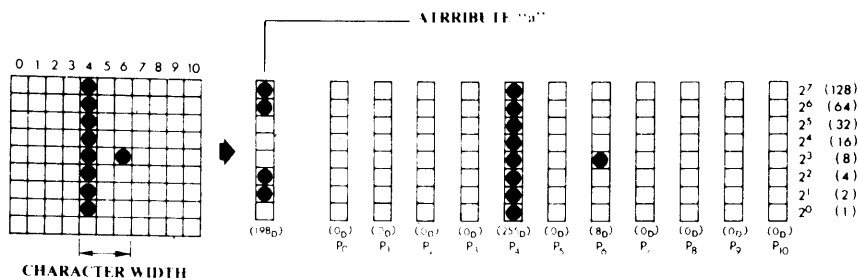

## Printing the Character of the Extended Table

The following table includes, besides the normal IBM characters, other characters and special symbols that replace the commands LF, CR, FF, etc.

Fig. 14-4  
Extended IBM Proprinter Table

|                |                |                |                | b <sub>8</sub> | b <sub>7</sub> | b <sub>6</sub> | b <sub>5</sub> |   |   |   |   |   |   |   |     |   |   |   |   |    |   |  |  |
|----------------|----------------|----------------|----------------|----------------|----------------|----------------|----------------|---|---|---|---|---|---|---|-----|---|---|---|---|----|---|--|--|
|                |                |                |                | 0              | 0              | 0              | 0              | 0 | 0 | 0 | 0 | 0 | 1 | 1 | 1   | 1 | 1 | 1 | 1 | 1  |   |  |  |
|                |                |                |                | 0              | 0              | 0              | 0              | 1 | 1 | 1 | 1 | 0 | 0 | 0 | 0   | 1 | 1 | 1 | 1 | 1  |   |  |  |
|                |                |                |                | 0              | 0              | 1              | 1              | 0 | 0 | 1 | 1 | 0 | 0 | 1 | 1   | 0 | 0 | 1 | 1 | 1  |   |  |  |
|                |                |                |                | 0              | 1              | 0              | 1              | 0 | 1 | 0 | 1 | 0 | 1 | 0 | 1   | 0 | 1 | 0 | 1 | 0  | 1 |  |  |
| b <sub>4</sub> | b <sub>3</sub> | b <sub>2</sub> | b <sub>1</sub> |                | 0              | 1              | 2              | 3 | 4 | 5 | 6 | 7 | 8 | 9 | A   | B | C | D | E | F  |   |  |  |
| 0              | 0              | 0              | 0              | 0              |                |                | SP             | 0 | @ | P | \ | p | Ç | É | á   | ⋮ | L | I | α | ≡  |   |  |  |
| 0              | 0              | 0              | 1              | 1              |                |                | !              | 1 | A | Q | a | q | ü | æ | í   | ⋮ | I | T | β | ±  |   |  |  |
| 0              | 0              | 1              | 0              | 2              |                |                | "              | 2 | B | R | b | r | é | Æ | ó   | ⋮ | T | T | Γ | ≥  |   |  |  |
| 0              | 0              | 1              | 1              | 3              | ♥              |                | #              | 3 | C | S | c | s | â | ô | ú   | ⋮ | T | T | Π | ≤  |   |  |  |
| 0              | 1              | 0              | 0              | 4              | ♦              | ¶              | \$             | 4 | D | T | d | t | ä | ö | ñ   | ⋮ | T | T | Σ | ↷  |   |  |  |
| 0              | 1              | 0              | 1              | 5              | ♣              | §              | %              | 5 | E | U | e | u | à | ò | Ñ   | ⋮ | T | T | σ | J  |   |  |  |
| 0              | 1              | 1              | 0              | 6              | ♠              |                | &              | 6 | F | V | f | v | á | û | ä   | ⋮ | T | T | " | ⋮  |   |  |  |
| 0              | 1              | 1              | 1              | 7              |                |                | '              | 7 | G | W | g | w | ç | ù | ö   | ⋮ | T | T | τ | "  |   |  |  |
| 1              | 0              | 0              | 0              | 8              |                |                | (              | 8 | H | X | h | x | ê | ÿ | ç   | ⋮ | T | T | ø | °  |   |  |  |
| 1              | 0              | 0              | 1              | 9              |                |                | )              | 9 | I | Y | i | y | ë | Ö | Γ   | ⋮ | T | T | θ | ▪  |   |  |  |
| 1              | 0              | 1              | 0              | A              | →              |                | *              | : | J | Z | j | z | è | Ü | Γ   | ⋮ | T | T | Ω | —  |   |  |  |
| 1              | 0              | 1              | 1              | B              | ←              |                | +              | ; | K | [ | k | { | ï | ç | 1/2 | ⋮ | T | T | δ | √  |   |  |  |
| 1              | 1              | 0              | 0              | C              |                |                | ,              | < | L | \ | l | l | î | É | 1/4 | ⋮ | T | T | ∞ | ∞  |   |  |  |
| 1              | 1              | 0              | 1              | D              |                |                | -              | = | M | ] | m | } | ì | Y | i   | ⋮ | T | T | φ | 2  |   |  |  |
| 1              | 1              | 1              | 0              | E              |                |                | .              | > | N | ^ | n | ~ | Ä | R | <<  | ⋮ | T | T | € | ■  |   |  |  |
| 1              | 1              | 1              | 1              | F              |                | Q              | /              | ? | O | _ | o |   | À | f | >>  | ⋮ | T | T | ∅ | SP |   |  |  |

The user can print one or more characters taken from the "extended" table, issuing one of the two following codes.

ESC \ m n Sets the printing of a determined number of characters taken from the “extended“ table, defined by parameters “m“ and “n“ and computed as follows:  $m + (n \times 256)$ .

If the printer receives a code not assigned to a character, it simply advances one character pitch (see “extended“ table).

During the operation of the ESC \ all the control codes are not active. When the printing of the characters defined by parameters “n“ and “m“ is terminated, the Character Table previously selected (by means of ESC 6 or ESC 7) is restored, the ESC \ code becomes inactive and the control codes are operating once again.

```
LPRINT CHR$(27);CHR$(92);CHR$(m);CHR$(n);
or
LPRINT CHR$(27);“\“;CHR$(m);CHR$(n);
```

ESC ^ Sets the printing of one character taken from the “extended“ table. This sequence is normally used to print a control code. For further information, refer to ESC \.