

DIVISION OF BENDIX AVIATION CORPORATION

LOS ANGELES 45, CALIFORNIA

PROGRAM PREPARATION ROUTINE G-15D

TITLE (PPR-D1)

Prepared by: H. Lewis & E. Williams

Approved by: *J. J. ...*

Page 1 of 7

Date: 3-8-57

No. 1000

INTRODUCTION

The functions of PPR-D1 are to facilitate:

- (1) program assembly by the conversion to binary of commands or numbers entered in decimal form, followed by their storage in assigned locations;
- (2) program tape preparation, including the collation of new programming with copies of subroutines from library tapes;
- (3) program inspection and correction during checkout;
- (4) punched tape duplication or typeout.

The basic package is stored in lines 05, 16, and 17. Commands executed from line 05 prepare for the entry of instructions or data from the typewriter. Lines 16 and 17 are transferred to line 19 for the execution of commands which provide for the interpretation and disposition of typed input to line 23 and for initiating certain typeouts from AR. Control is returned to line 05 for operations involving either input from punched tape or output from line 19.

Optionally, a subroutine to convert decimal numbers (distinguished from commands) to binary form may be stored in line 15 and operated under the control of the main program.

Line 18 is used for working storage: it receives tape input from line 19; commands are stored there after conversion from decimal to

INTRODUCTION (Continued)

binary; any long line may be transferred to line 18 for the examination, insertion, or alteration of selected words; etc.

The arithmetic registers and all four-word lines are used by the routine.

LOADING

Following the number track, first block on the PPR-D1 tape, is a short loading routine. When the loader has been read, either automatically as part of the DC turn on procedure, or by use of the "p" key, the operator sets the Compute Switch to either BP or GO. The loader checks the number track; if it should be incorrect, the computer halts. After each of the next three blocks comprising PPR-D1 is read, its sum is checked and if correct is loaded into line 17, 16 and 05 respectively. An error in the check sum causes the block to be read again. The loading procedure terminates with the computer prepared to accept input from the typewriter. Standard formats are stored for AR and line 19 output.

After loading PPR-D1, the operator types a coded instruction to designate which of several modes of operation is desired. Instructions consist of three or more digits, followed by Tab s, as listed in Table I and described in detail below. Except where otherwise specified, the Compute Switch remains in either the GO or BP position, and the Punch Switch is OFF.

LOADING (Continued)

When any entry is made from the typewriter, the indicator lights show: Source, 11100; Destination, 11111; Command Line 101; Input-Output, 01100. This configuration is reached: (a) at the conclusion of initial loading, (b) after the execution of most instructions (exceptions: codes w ab), (c) after the conversion and storage of decimal input, (d) at any time during computation, input, or output by the striking of "f" with the Enable Switch ON.

TABLE I - INSTRUCTIONS

NOTE: All instructions are followed by Tab s.

cvab	Decimal number input
w00	Read tape, type check sum
w01	Read tape, type check sum, type out
w02	Read tape, type check sum, punch tape
w03	Read tape, type check sum, type and punch
x00	Clear L 18
x01	Punch number track
klijx02	Line kl to L 18, type word ij
klx03	L 18 to line kl
cijx04	Next command from line c, word ij (c=0,1,2,3)
x05	Type out L 18
x06	Punch L 18
x07	Type and punch L 18
yab	Decimal command input
zab	Tab \neq $d_1d_2d_3d_4d_5d_6d_7$ Hex input

T I T L EHEX INPUT

To enter a word of 7 hex digits and sign, requiring no conversion, the operator types in the instructions zab, followed by Tab, sign, seven digits, Tab s. After an automatic carriage return, the location (ab) is typed out from the left-hand margin and the word entered is stored in 18.ab. If this location was not empty, its former contents are typed out, followed by the new contents. If the location was empty, only the new contents are typed out. After type out, the operator may enter any desired instruction. The Compute Switch remains in either GO or BP.

DECIMAL COMMAND INPUT

To prepare for the entry of one or more commands for conversion from decimal form, the operator first types yab Tab s. After an automatic carriage return, the location (ab) of the first command is typed out. After type out, the operator types in a decimal command, which is converted and stored in 18.ab. The converted command is typed out, followed by a carriage return and type out of the next command location. This, in general, will be the N of the previous command. An exception occurs in the case of a command with S28, D31, where the next location is N+1.

In case the location in which a converted command is to be stored is not empty, its contents are typed out following the type out of the location. In this way, the operator knows when he is replacing something previously stored.

If a location number greater than u7 is specified, the bell rings and no typeout occurs.

TITLE

The operator may enter any instruction in lieu of a command. For example, the second sequence of commands after a branch point may be entered following a new instruction of the form yab Tab s.

No command is converted or stored unless this mode of operation has first been established by the proper instruction.

DECIMAL TO BINARY NUMBER CONVERSION ROUTINE

To prepare for conversion of decimal numbers, the decimal to binary number conversion routine must have been previously filled into line 15. It is stored on paper tape immediately following the basic package and may be filled into line 15 using the following instructions: "w00 tab s" with compute switch at "BP". The routine will be read and the memory sum "-.uw25440" typed out. With enable switch on, strike "f" and put compute switch on "GO". Then the instruction "15x03 tab s" is typed. This completes the filling. Unless line 15 is subsequently altered the routine need not be refilled during program preparation.

The instruction "cvab tab s" when typed prepares for number conversion. If the conversion routine is not in line 15, a bell rings and the computer is set to receive another instruction. Otherwise, location "ab" is typed after a carriage return by the computer.

Any number containing up to 14 decimal digits is then entered followed by "tab s". The number is then converted according to the code "c" in the instruction. The following 4 combinations are possible:

DECIMAL TO BINARY NUMBER CONVERSION ROUTINE (Continued)

- c = 0 single precision, fractions. 8 digits must
be filled, less preceding zeros.
- c = 1 single precision, integer. Up to 8 digits
can be filled. Converted number is scaled 2^{-28}
- c = 4 double precision, fractions. 14 digits must be
filled, less preceding zeros.
- c = 5 double precision, integers. Up to 14 digits can
be filled. Converted number is scaled 2^{-57} .

For c = 4 or c = 5, the converted number is stored in locations
ab and ab+1. Location ab must be even.

Error Alarms:

- c = 4 or c = 5 with ab an odd location
- c = 0 with 9 or more digits filled.

In this case the bell rings and the location ab is retyped.

NOTE: If an error is made in filling, retype the correct instruction
"cvab tab s".

T I T L EEXAMPLES OF USE OF PPR-D1

It is assumed that the program preparation routine has been loaded into the computer and the indicator lights have the proper configuration (see page 3).

For clarity, the symbols underlined below indicate information typed by the computer, those not underlined are typed by the operator.

		<u>Explanation</u>
x00	s	No typeout, line 18 was cleared
y14	s	
<u>.14</u>	095300128 s <u>.893503w</u>	y14 prepared for entering a decimal command in 18.14. 893503w is the converted form of the command entered.
z12	<u>-132z491</u> s	} Hex input in 18.12
<u>.12</u>	<u>-.132z491</u>	
z12	<u>-zz00zz1</u> s	} Hex input in 18.12. The previous contents are first typed by the computer, then the current contents.
<u>.12</u>	<u>-.132z491</u> <u>-.zz00zz1</u>	
yv9	s	Bell rang, ab > u7
4v60	s	
<u>.60</u>	<u>-12500000000000</u> s <u>.0000001</u>	<u>-.2000000</u> <u>Double precision fractional decimal number conversion.</u> The least significant half which is stored in 18.60 is typed first followed by the most significant half stored in 18.61 (with sign.) The least significant digit for fractions is always odd.

TITLE

DECIMAL COMMAND
FORMAT

23.01

23.00

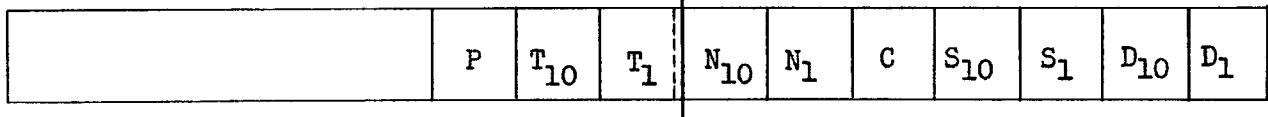

P = Prefix

ABBREVIATIONS

T₁₀ } = Tens digit of T number
T₁ } = Units digit of T number

d.p. = Double precision

N₁₀ } = Next command number
N₁ } =

d.c. = Decimal command

b.p. = Break point

C = Characteristic

s/d = Single or double

t.c. = Transfer control

S₁₀ } = Source
S₁ } =

n.t. = Number track

D₁₀ } = Destination
D₁ } =

L = Location

COMMENTS AND SPECIAL REGISTERS

$$21.01 = \text{Mode Register} = \left[ab d_4 d_3 d_2 d_1 I \right]$$

I = Instruction digit

ab = Location in Line 18 for all instruction digits " v or y or z".

d₄, d₃, d₂, d₁ = Special digits

LOADER

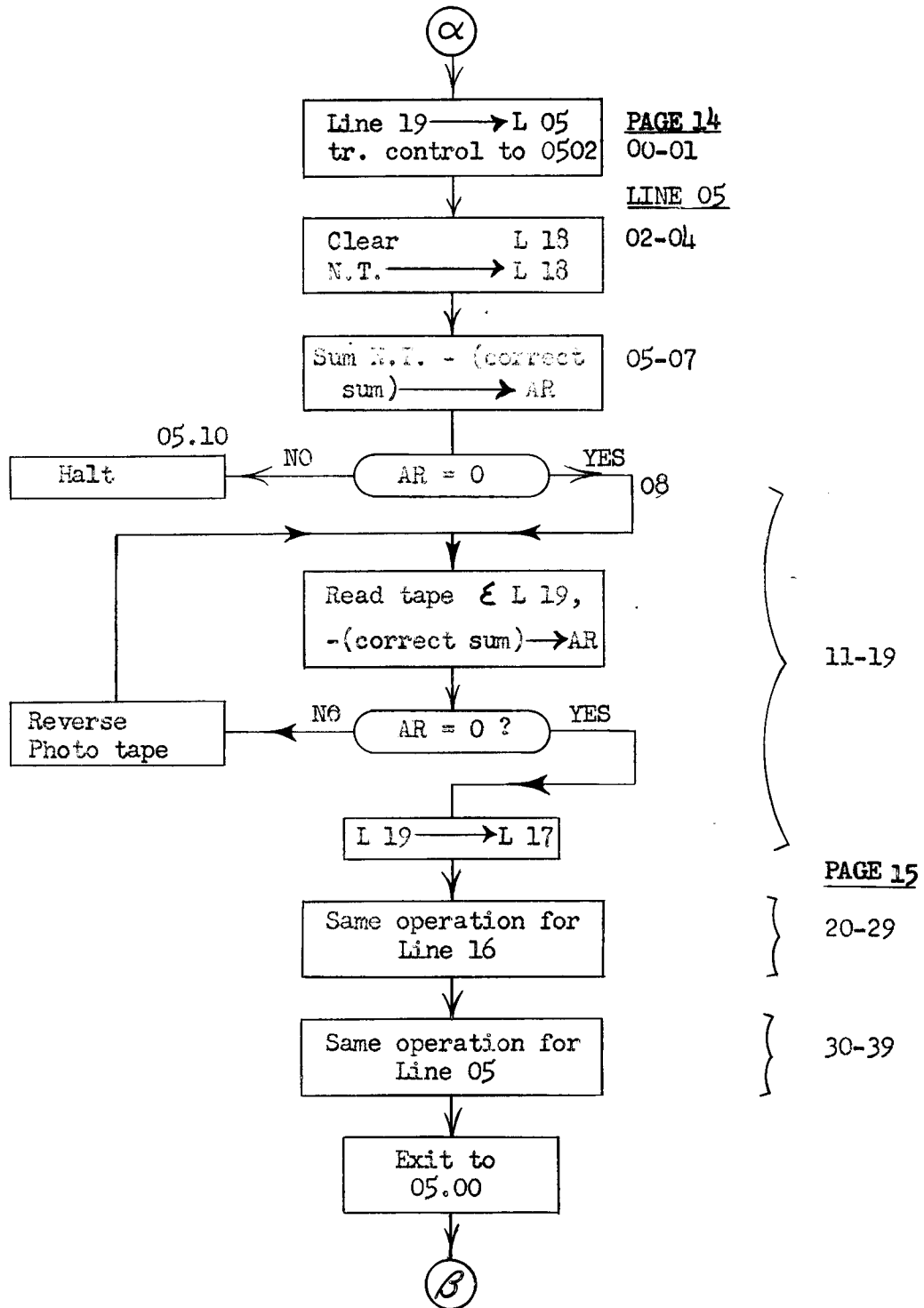

FLOW CHART

Start of PPR Routine

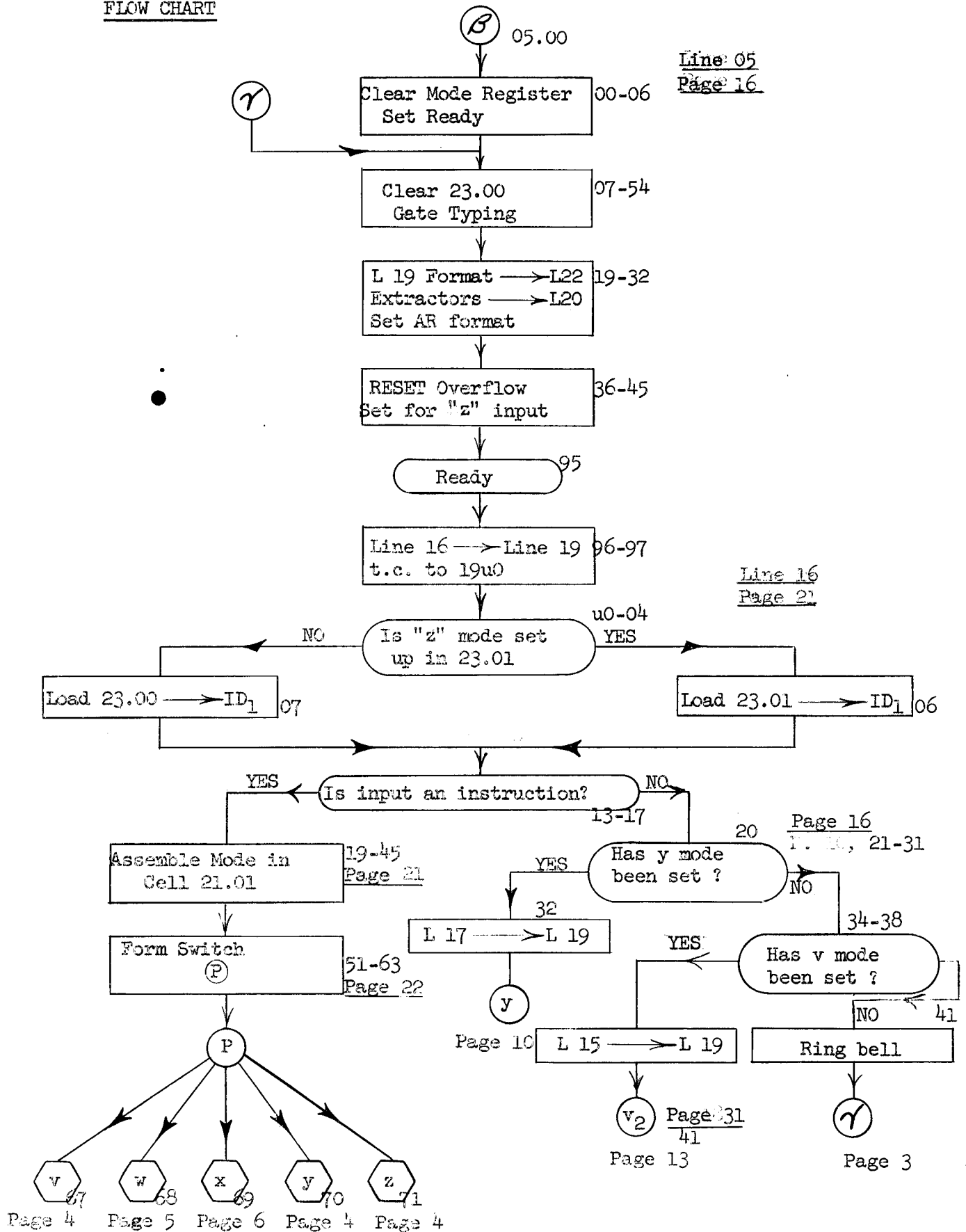

NUMBER CONVERSION ROUTINE

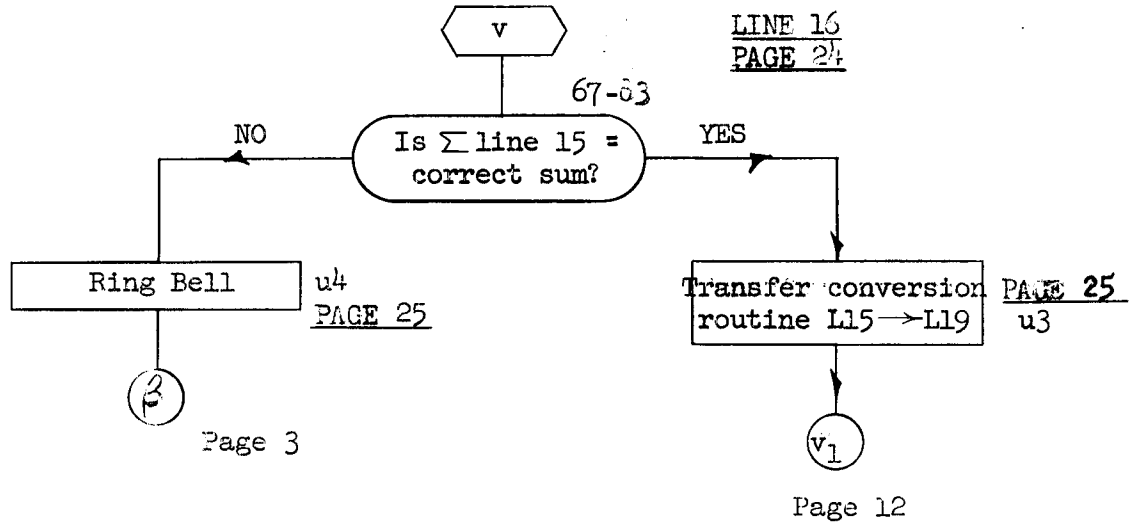

DECIMAL COMMAND

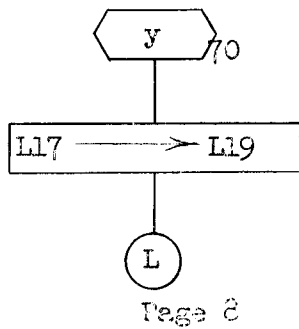

HEX INPUT LINE 16
PAGE 22

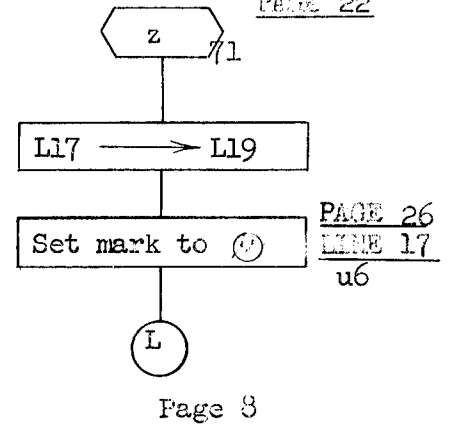

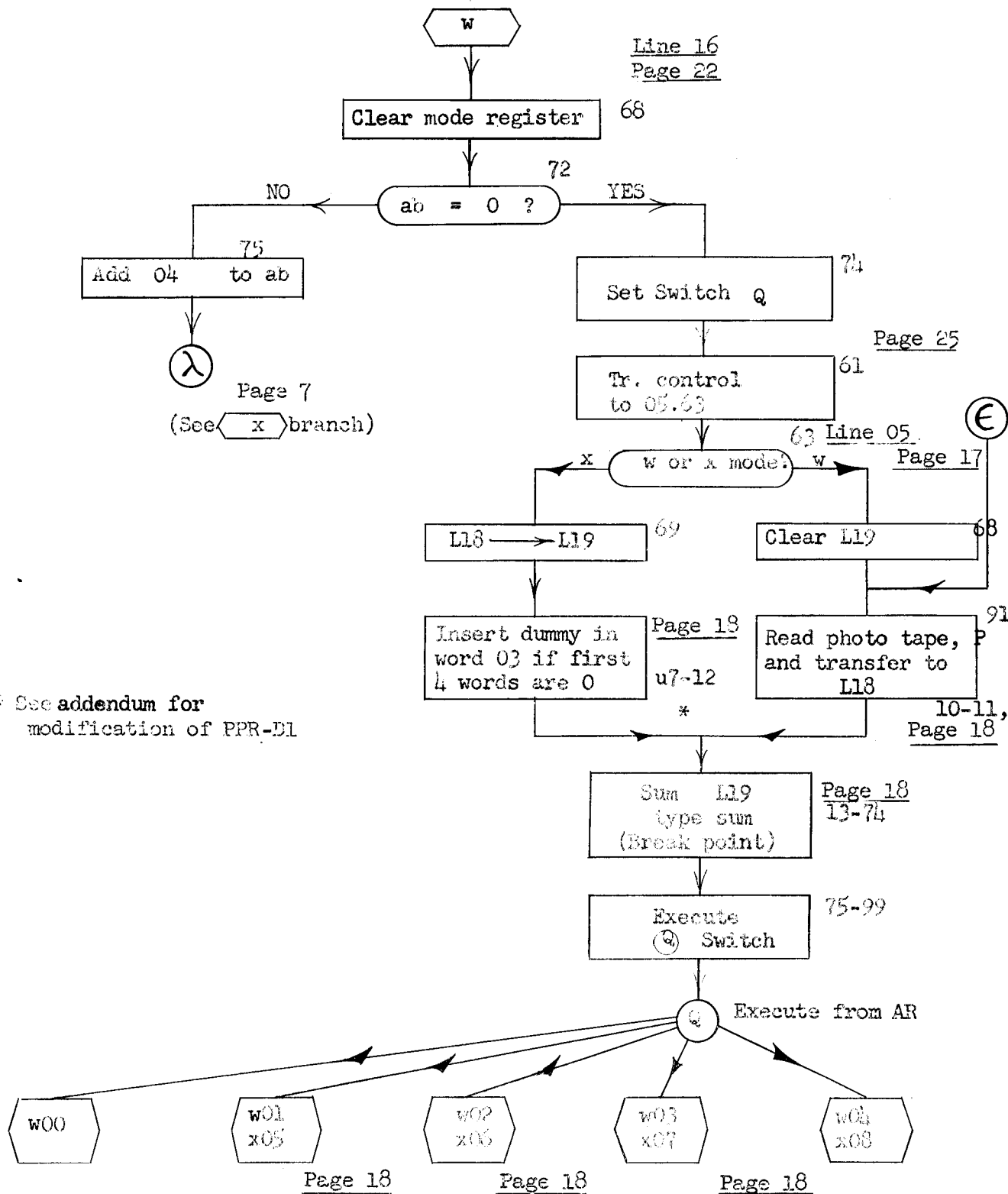

* See addendum for modification of PPR-D1

TITLE

Line 16

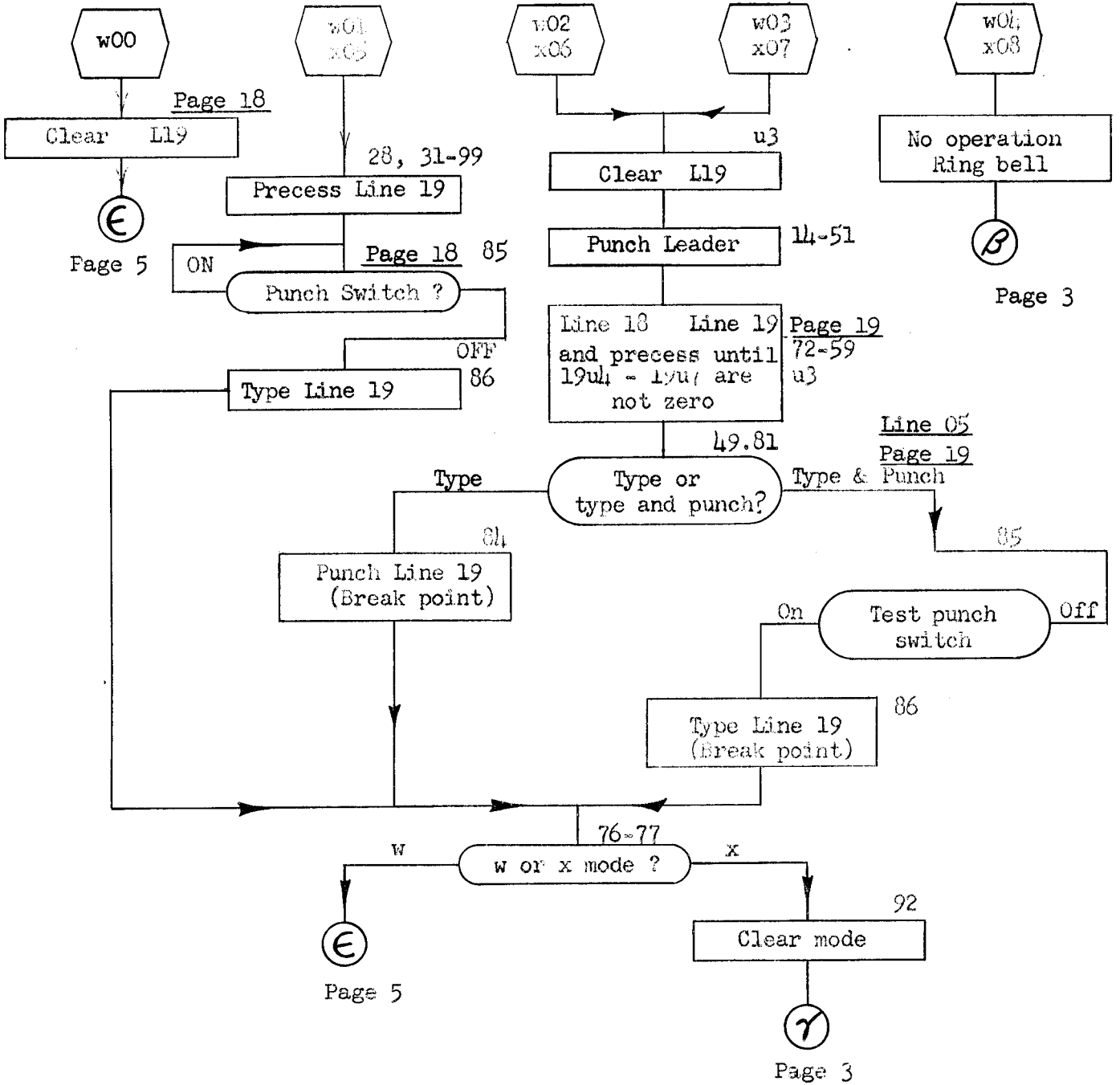

TITLE

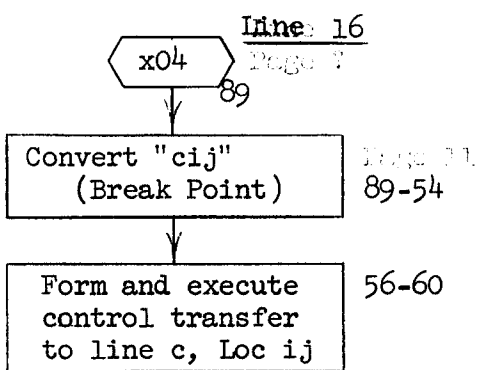
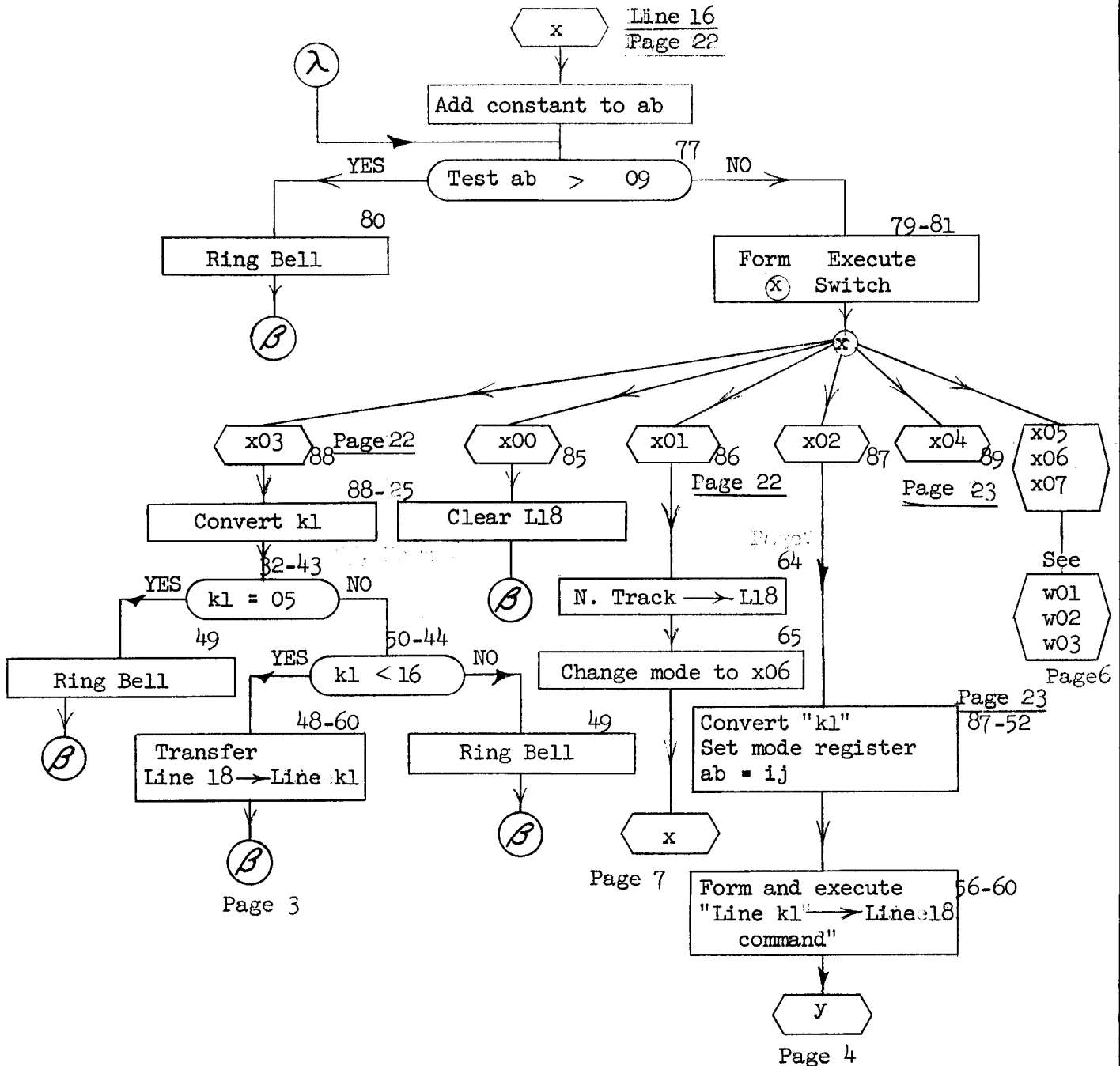

LINE 17
PAGE 26

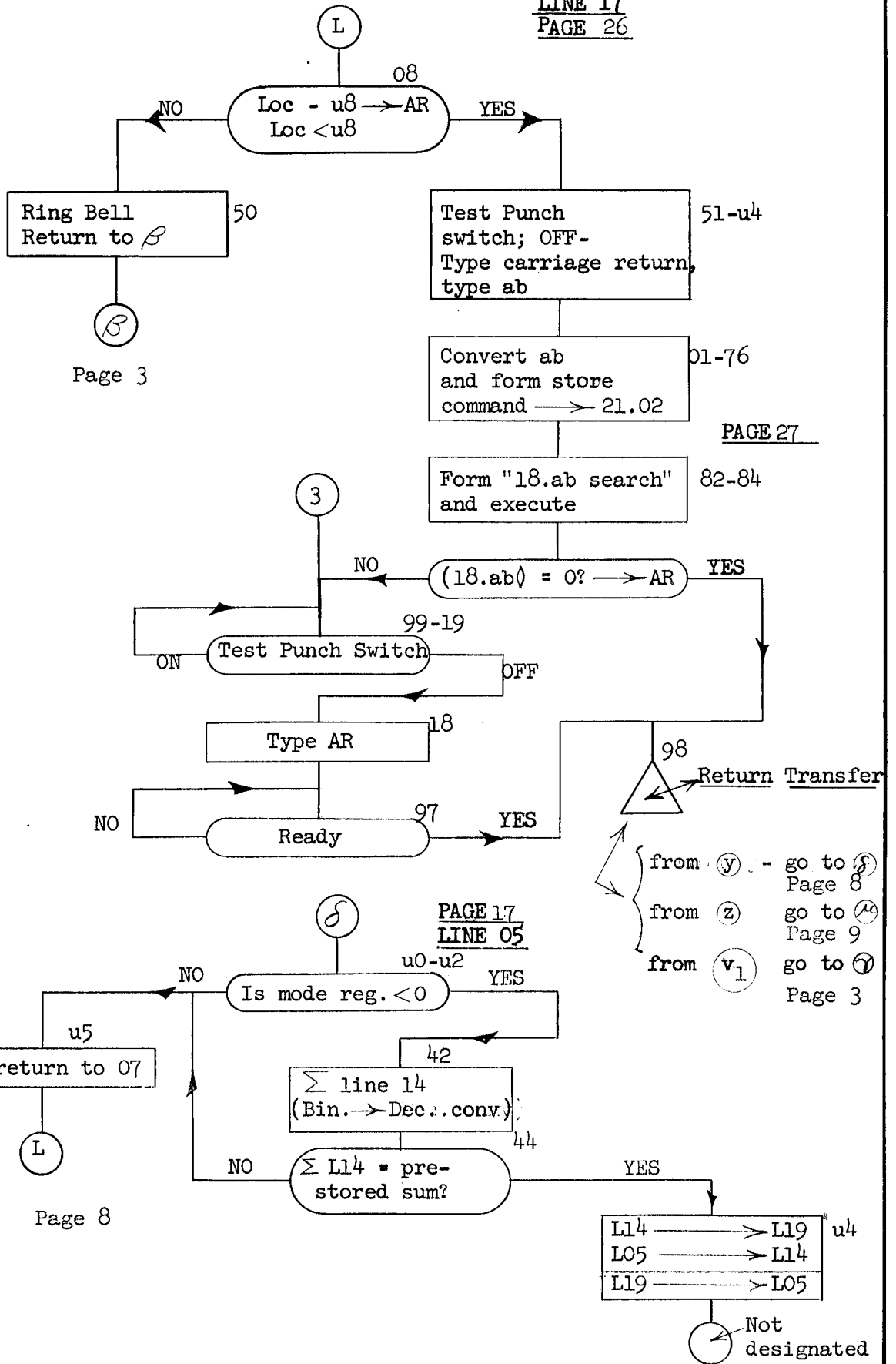

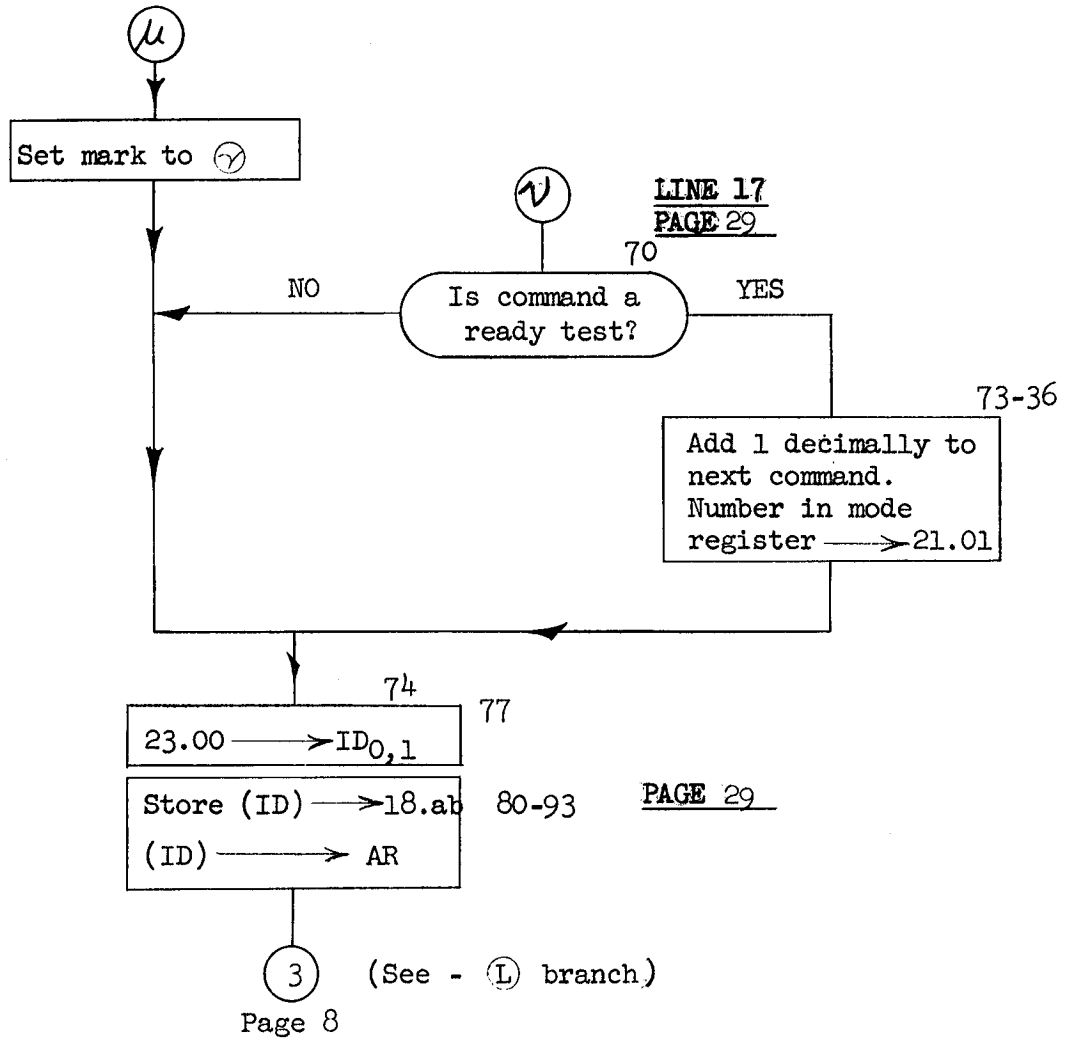

TITLE

COMMAND CONVERSION ROUTINE

LINE 17
PAGE 27

P = Prefix

T₁₀ = Tens digit of T no.

T₁ = Units digit of T no.

N₁₀ } = Next Command no.

N₁ }

C = Characteristic

S₁₀ } = Source

S₁ }

D₁₀ } = Destination

D₁ }

L = Location

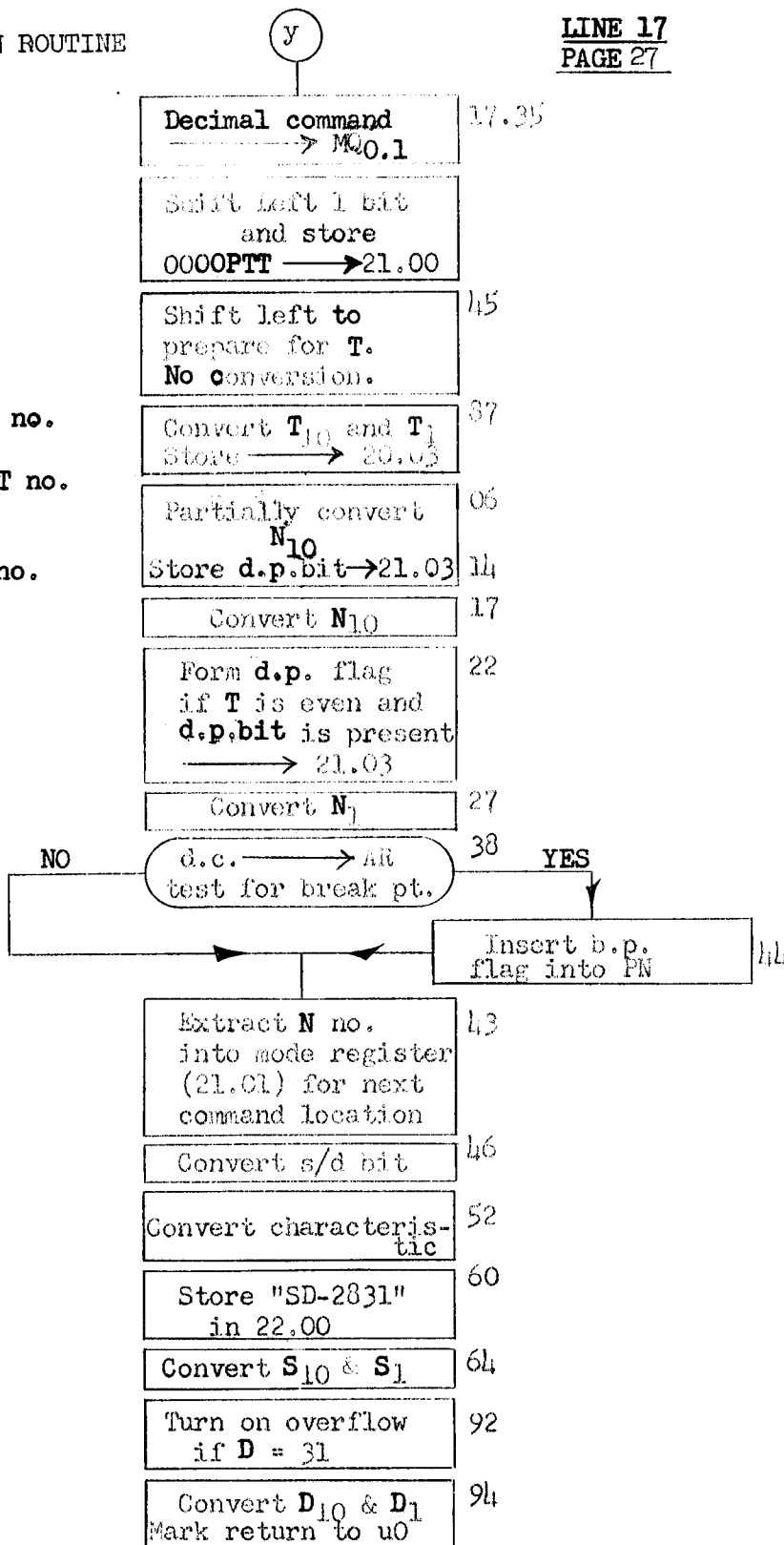

LINE 17
PAGE 28

COMMAND CONVERSION ROUTINE (Cont.)

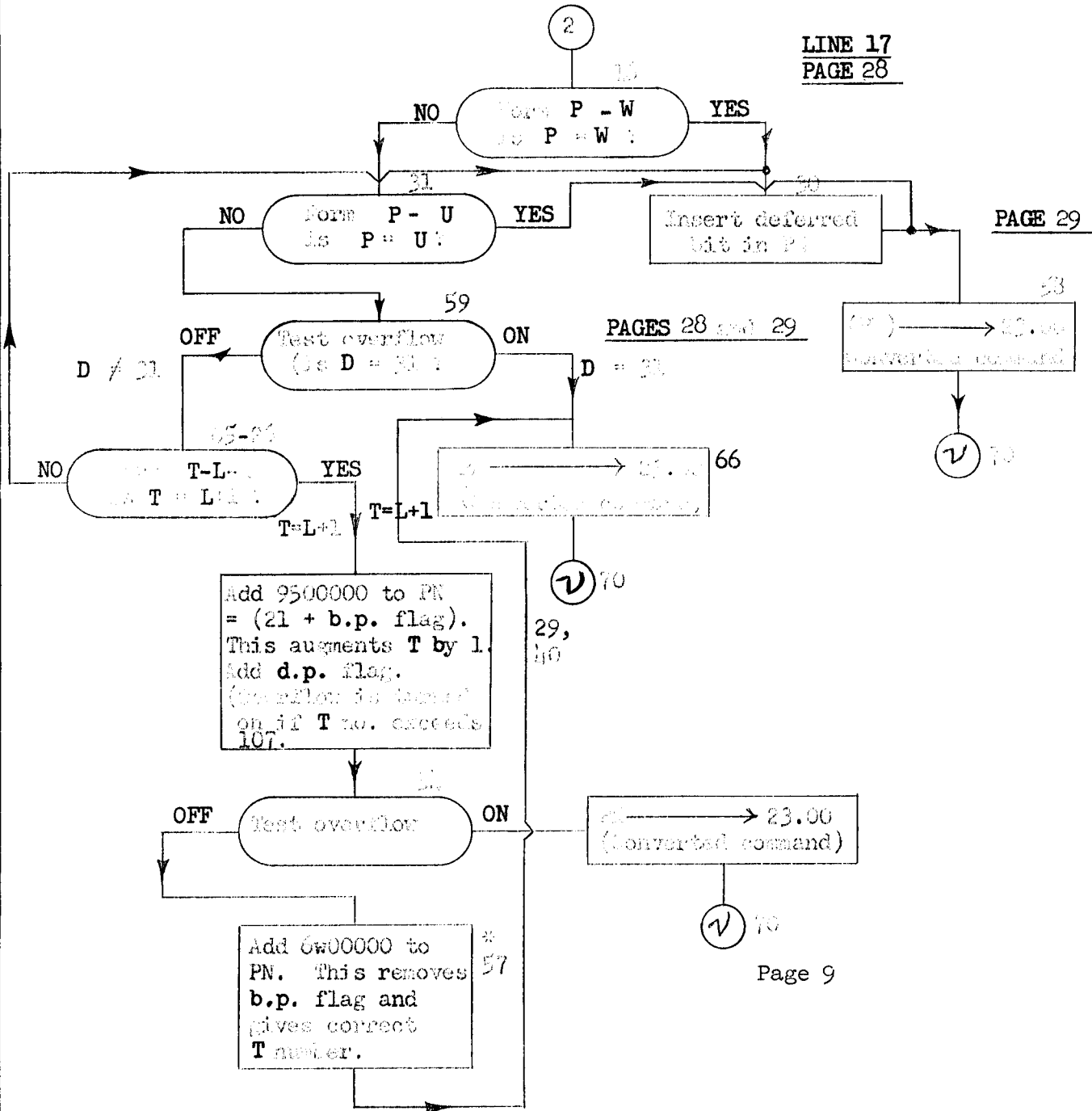

* Note: 9500000
 6w00000
 Overflow 0100000

TITLE

DECIMAL NUMBER CONVERSION ROUTINE

LINE 15

PAGE 31

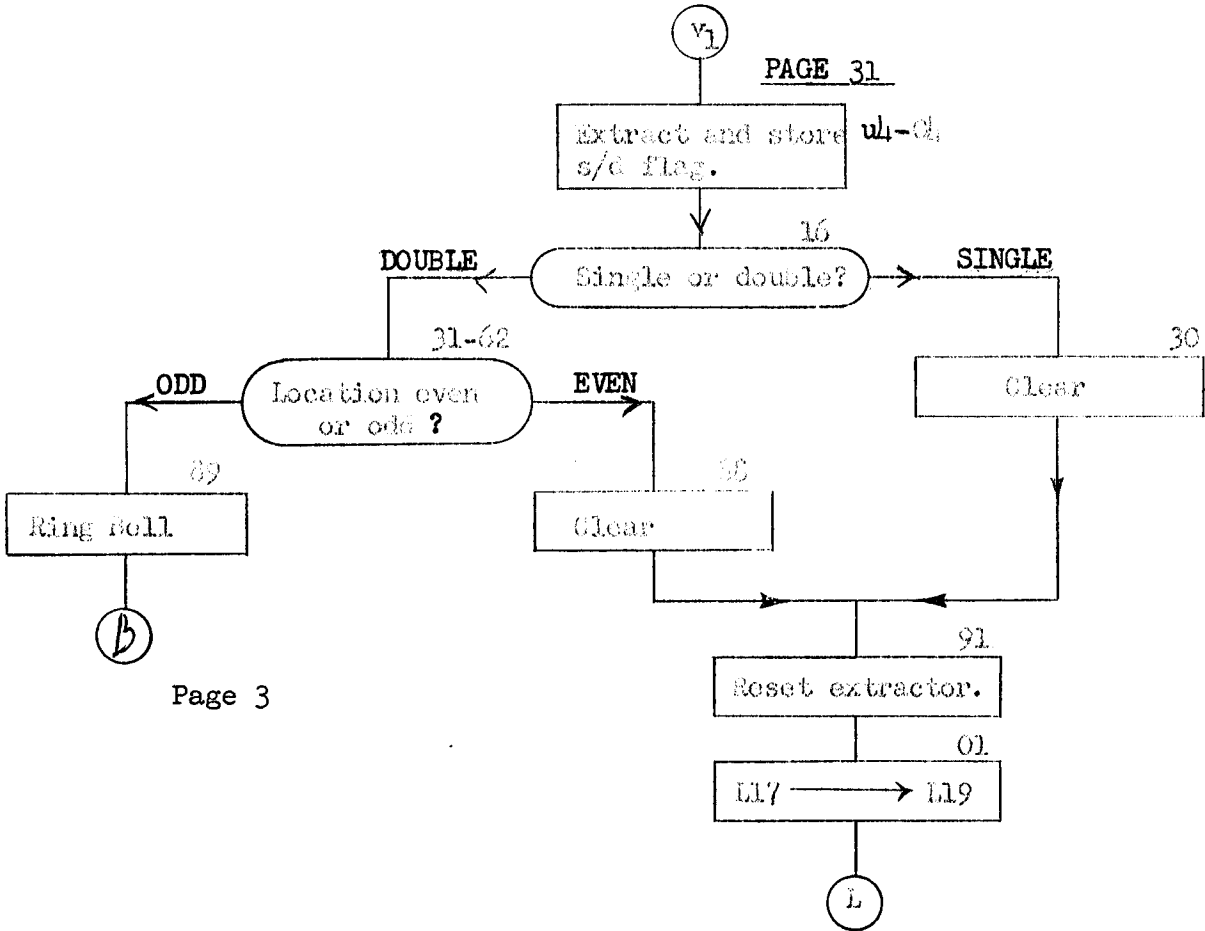

Page 3

Page 8

TITLE

DECIMAL NUMBER CONVERSION ROUTINE

LINE 15

PAGES 31 and 33

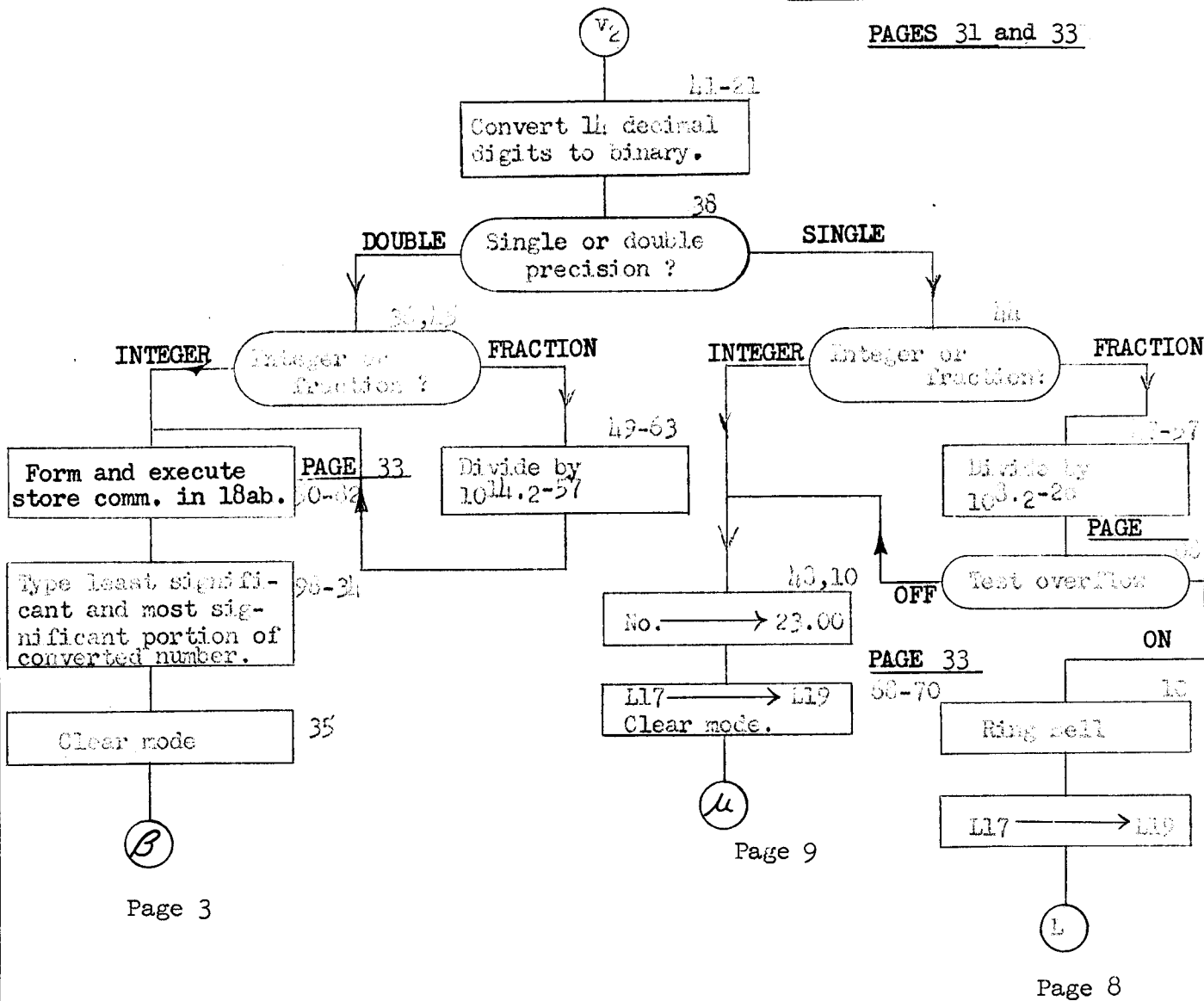

Page 3

Page 9

Page 8

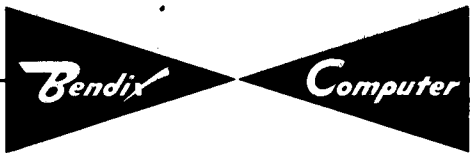

Los Angeles 45, California

Page 14 of 34

G-15 D
PROGRAM PROBLEM PPR-D1

Prepared by S. H. Lewis

Date: 9/24/56

(Loader)

1000

G-15D

Line 05

0	1	2	3	L	P	T or Lk	N	C	S	D	BP	NOTES
4	5	6	7	00	u	01	01	0	19	05		(19) → 05
8	9	10	11	01		03	02	5	21	31		N.C. from 05.02
12	13	14	15	02		05	03	0	23	31		Clear
16	17	18	19	03	u	04	04	0	24	18		0 = (MQ _{0,1}) → 18
20	21	22	23	04		05	05	1	31	31		N.T. → 18
24	25	26	27	05		06	07	3	05	28		Σ (NT) = (05.06) → AR
28	29	30	31	06								Σ (NT) = 147x86w
32	33	34	35	07	u	08	08	1	18	29		(18) + → AR+
36	37	38	39	08		09	09	0	28	27		(AR) → test
40	41	42	43	09		11	11	0	15	31		Read Tape
44	45	46	47	10		00	00	0	16	31		Halt
48	49	50	51	11		12	13	3	05	28		Σ (17) = (05.12) → AR
52	53	54	55	12								Σ (17) = -5766068
56	57	58	59	13		13	13	0	28	31		Ready ?
60	61	62	63	14	u	15	15	1	19	29		(19) + → AR+
64	65	66	67	15		16	16	0	28	27		(AR) → Test
68	69	70	71	16	u	17	20	0	19	17		(19) → 17
72	73	74	75	17		18	18	0	06	31		Read Back
76	77	78	79	18		18	18	0	28	31		Ready ?
80	81	82	83	19		21	11	0	15	31		Read Tape
84	85	86	87	20		22	21	0	15	31		Read Tape
88	89	90	91	21		22	23	3	05	28		Σ (16) = (05.22) → AR
92	93	94	95	22								Σ (16) = -6y72635
96	97	98	99	23		23	23	0	28	31		Ready ?
u0	u1	u2	u3	24	u	25	25	1	19	29		(19) + → AR+
u4	u5	u6		25		26	26	0	28	27		(AR) → Test

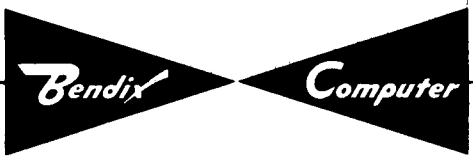

Los Angeles 45, California

Page 15 of 34

Date: 9/24/56

Line 05

G-15 D

Prepared by S. H. Lewis

PROGRAM PROBLEM :

PPR-D1

(Loader)

(#1000)

				L	P	T or L _k	N	C	S	D	BP	NOTES
0	1	2	3									
4	5	6	7	26	u	27	30	0	19	16		(19) → 16
8	9	10	11	27		28	28	0	06	31		Read Back
12	13	14	15	28		28	28	0	28	31		Ready ?
16	17	18	19	29		31	21	0	15	31		Read Tape
20	21	22	23	30		31	31	0	15	31		Read Tape
24	25	26	27	31		32	33	3	05	28		$\overline{\sum (05)} = (05.32) \xrightarrow{-} \text{AR}$
28	29	30	31	32								$\overline{\sum (05)} = -zw54103$
32	33	34	35	33		33	33	0	28	31		Ready ?
36	37	38	39	34	u	35	35	1	19	29		(19) $\xrightarrow{+}$ AR+
40	41	42	43	35		36	36	0	28	27		(AR) → Test
44	45	46	47	36	u	37	00	0	19	05		(19) → 05
48	49	50	51	37		38	38	0	06	31		Read Back
52	53	54	55	38		38	38	0	28	31		Ready ?
56	57	58	59	39		41	31	0	15	31		Read Tape
60	61	62	63									
64	65	66	67									
68	69	70	71									
72	73	74	75									
76	77	78	79									
80	81	82	83									
84	85	86	87									
88	89	90	91									
92	93	94	95									
96	97	98	99									
u0	u1	u2	u3									
u4	u5	u6										

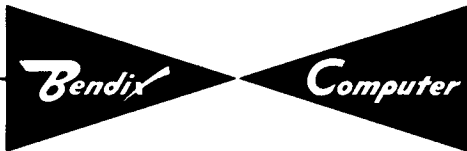

G-15 D
PROGRAM PROBLEM :

PPR-DL (#1000)

Line 05

0	1	2	3	L	P	T or L _k	N	C	S	D	BP	NOTES
4	5	6	7	00		01	06	0	16	21		0 = (16.01) → 21.1
8	9	10	11	{ 06		07	07	0	00	31		Set Ready
12	13	14	15	{ 07		08	54	0	05	23		0 = (05.08) → 23.0 (2)
16	17	18	19	08								0
20	21	22	23	54		56	19	0	12	31		Type in
24	25	26	27	19	u	24	27	0	05	22		L 19 Format = (05.20-23) → 22
28	29	30	31	27	u	31	32	0	16	20		Extractors = (16.28-30) → 20.0-2
32	33	34	35	32		02	36	4	16	03		Std. AR Format = (16.23) → 03.2,3
36	37	38	39	36		38	44	0	29	31		Overflow → test
40	41	42	43	{ 44		48	95	0	20	21		$z \cdot 2^{-20} = (20.0) \rightarrow 21.0$
44	45	46	47	{ 45		48	95	0	20	21		$z \cdot 2^{-20} = (20.0) \rightarrow 21.0$
48	49	50	51	{ 95		95	95	0	28	31		Ready ?
52	53	54	55	{ 96	u	97	97	0	16	19		(16) → 19
56	57	58	59	97		99	u0	6	21	31		N.C. from 19°u0 {mark 98}
60	61	62	63									
64	65	66	67									
68	69	70	71									
72	73	74	75									
76	77	78	79									
80	81	82	83									
84	85	86	87									
88	89	90	91									
92	93	94	95									
96	97	98	99									
u0	u1	u2	u3									
u4	u5	u6										

0	1	2	3	L	P	T or L _k	N	C	S	D	BP	NOTES
4	5	6	7	u0		u1	u2	0	21	28		(21.1) → AR Return from 17 (y)
8	9	10	11	u2		u4	u5	0	22	31		(T ₁ ·AR) → test
12	13	14	15	42	u	43	43	1	14	29		(14) ⁺ → AR +
16	17	18	19	43		44	u4	0	28	27		(AR) → test
20	21	22	23	{u4	u	u5	02	0	14	19		(14) → 19
24	25	26	27	{u5	w	07	08	6	21	31		M.T. _(A) → 19 (L)
28	29	30	31	{u6		09	42	3	05	28		Σ(14) = (05.09) → AR
32	33	34	35	02	u	03	04	0	05	14		(05) → 14
36	37	38	39	04	u	05		0	19	05		(19) → 05
40	41	42	43	01	w	07	74	6	21	31		M.T. _(A) → 19 (Z)
44	45	46	47	63		65	68	0	21	27		21.1 → test
48	49	50	51	{68	u	69	91	1	26	19		0 = (PN _{0,1}) → 19 (w)
52	53	54	55	{69	u	70	u7	0	18	19		(18) → 19 (See pg. 18) (x)
56	57	58	59	{76		76	76	0	28	31		Ready ?
60	61	62	63	{77		81	91	0	21	27		(21.1) → test
64	65	66	67	{91		93	10	0	15	31		Read Tape (See pg. 18) (w)
68	69	70	71	{92		01	07	0	16	21		0 = (16.01) → 21.1 (x)
72	73	74	75									
76	77	78	79									
80	81	82	83									
84	85	86	87									
88	89	90	91									
92	93	94	95									
96	97	98	99									
u0	u1	u2	u3									
u4	u5	u6										

0	1	2	3	L	P	T or L _k	N	C	S	D	BP	NOTES
4	5	6	7	{10		10	10	0	28	31		Ready ?
8	9	10	11	{11	u	12	13	0	19	18		(19) → 18
12	13	14	15	u7	u	24	32	0	19	27		(19·0-3) → test
16	17	18	19	{12		03	13	0	05	19		4400000 = (05.03) → 19.03
20	21	22	23	{13		14	15	1	26	28		0 = (PN ₀) ⁺ → AR
24	25	26	27	15	u	16	17	1	19	29		(19) ⁺ → AR+
28	29	30	31	{17		19	16	1	17	31		Punch Switch → test
32	33	34	35	{16		18	74	0	08	31	-	Type AR (✓Σ)
36	37	38	39	{74		74	74	0	28	31		Ready ?
40	41	42	43	<75		78	99	0	21	28		(21.2) → AR
44	45	46	47	99		u1	u3	0	31	31		N.C. from AR
48	49	50	51	[AR (u3)]	u	u4	91	1	26	19]	[0 = (PN _{0,1}) ⁺ → 19] [w00]
52	53	54	55	[AR (u3)]	u	00	28	0	19	27]	[(19.u4-u7) → test] [w01 x05]
56	57	58	59	{28		30	30	5	21	31		No op
60	61	62	63	{29		31	87	5	21	31		No op
64	65	66	67	{30	u	31	31	2	19	19		(19) ^{tva} → 19
68	69	70	71	{31	u	32	34	2	19	19		(19) ^{tva} → 19
72	73	74	75	{34	u	35	35	2	19	19		(19) ^{tva} → 19
76	77	78	79	{35	u	36	99	2	19	19		(19) ^{tva} → 19
80	81	82	83	[99		u1	u3	0	31	31]	[N.C. from AR]
84	85	86	87	[AR (u3)]	u	u4	14	1	26	19]	[(PN _{0,1}) = 0 ⁺ → 19] [w02,03 x06,07]
88	89	90	91	14		39	46	0	05	28		C ₁ = 6062000 = (05.39) → AR
92	93	94	95	46		48	50	0	22	31		(T ₁ ·AR) → test
96	97	98	99	{50		01	24	0	10	31		Punch (Leader)
u0	u1	u2	u3	{51		53	72	0	00	31		Set Ready (See pg. 19)
u4	u5	u6		24		38	46	3	05	29		C ₂ = 00uv000 = (05.38) → AR

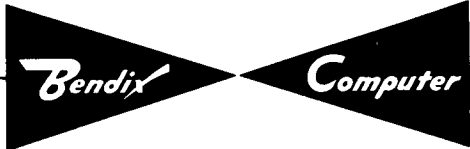

Prepared by S. H. Lewis

Date: 10/9/56

G-15 D
PROGRAM PROBLEM :

PPR-D1 (#1000)

Line 05

0	1	2	3	L	P	T or L _k	N	C	S	D	BP	NOTES
4	5	6	7	72		72	72	0	28	31		Ready → test
8	9	10	11	73	u	74	u3	0	18	19		(18) → 19
12	13	14	15	u3	u	00	48	0	19	27		(19.u4-u7) → test
16	17	18	19	48		50	56	5	21	31		No op
20	21	22	23	49		50	81	0	21	28		(21.2) → AR
24	25	26	27	56	u	57	57	2	19	19		(19) ^{tva} → 19
28	29	30	31	57	u	58	58	2	19	19		(19) ^{tva} → 19
32	33	34	35	58	u	59	59	2	19	19		(19) ^{tva} → 19
36	37	38	39	59	u	60	u3	2	19	19		(19) ^{tva} → 19
40	41	42	43	81		83	84	0	22	31		(T ₁ ·AR) → test
44	45	46	47	84		86	76	0	10	31	-	Punch 19 w02 x06
48	49	50	51	85		87	85	1	17	31		Punch Switch → test w03 x07
52	53	54	55	86		88	76	0	09	31	-	Type 19
56	57	58	59	87		89	86	1	17	31		Punch Switch → test
60	61	62	63	AR u3	u	u4	02	0	14	19		(14) → 19 w04 x08
64	65	66	67	03								4400000
68	69	70	71	20								0000110
72	73	74	75	21								00000x0
76	77	78	79	22								0000034
80	81	82	83	23								800000x
84	85	86	87	78	u	u4	14	5	26	19		w03 x07
88	89	90	91	90	u	u4	91	1	26	19		w00
92	93	94	95	94	u	00	28	0	19	27		w01 x05
96	97	98	99	98	u	u4	14	1	26	29		w02 x06
u0	u1	u2	u3	38								00uv000
u4	u5	u6										

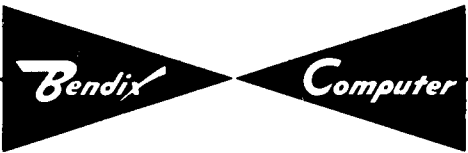

Los Angeles 45, California

Page 20 of 34

Prepared by S. H. Lewis

Date: 9/21/56

G-15 D
PROGRAM PROBLEM :

PPR-D1

(#1000)

Line 05

0	1	2	3	L	P	T or Lk	N	C	S	D	BP	NOTES
4	5	6	7	05								$10 \cdot 2^{-12} = 00u0000$
8	9	10	11	25								$2^{-12} = 0010000$
12	13	14	15	47								$2^{-28} = 0000001$
16	17	18	19	53								$2^{-16} = 0001000$
20	21	22	23	37								805x332
24	25	26	27	65								$10 \cdot 2^{-19} = 0001400$
28	29	30	31	79								$2^{-19} = 0000200$
32	33	34	35	88								$10 \cdot 2^{-4} = u000000$
36	37	38	39	u1								$2^{-4} = 1000000$
40	41	42	43	93								wz00000
44	45	46	47	40								u800000
48	49	50	51	52								0z00000
52	53	54	55	83								0001z2u
56	57	58	59	71								0100000
60	61	62	63	18								0000w00
64	65	66	67	33								0000200
68	69	70	71	82								0900000
72	73	74	75	80								20w3xy4 (For 16,79)
76	77	78	79	66								0600000
80	81	82	83	70								$\Sigma (15)$
84	85	86	87	09								$\Sigma (14)$
88	89	90	91	41								0000005
92	93	94	95	55								80002vz
96	97	98	99	62								000000u
u0	u1	u2	u3	39								6062000
u4	u5	u6		61								6w00000

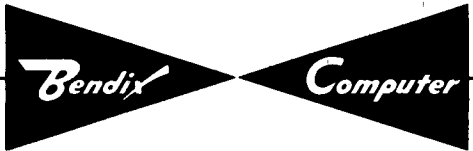

Los Angeles 45, California

Page 21 of 34

Prepared by S. H. Lewis

Date: 9/21/56

G-15 D
PROGRAM PROBLEM :

PPR-D1 (#1000)

Line 16

0	1	2	3	L	P	T or L _k	N	C	S	D	BP	NOTES
4	5	6	7	00	w	00	00	5	21	31		N.C. from 05.00
8	9	10	11	01								0
12	13	14	15	02								1000000
16	17	18	19	03								-8w00000
20	21	22	23	u0		u1	u2	0	23	28		(23.1) → AR
24	25	26	27	u2		u4	u7	3	27	29		(20·21 + 20·AR) ₀ → AR+
28	29	30	31	u7	u	24	24	0	22	02		(22·0...3) → 02.0·3
32	33	34	35	04		05	06	0	28	27		(AR) → test
36	37	38	39	06		09	10	0	23	25		(23.1) → ID ₁ (z)
40	41	42	43	07		08	10	6	23	25		(23.0) ^{tva} → ID ₁ (z̄)
44	45	46	47	10	u	13	13	2	25	21		(ID ₁) ^{tva} → 21.0
48	49	50	51	13		14	15	3	16	28		v·2 ⁻²⁰ = (16.14) → AR
52	53	54	55	15		16	17	0	31	29		(20·21) ₀ → AR+
56	57	58	59	17		19	19	0	22	31		(T ₁ ·AR) → test
60	61	62	63	19		16	36	0	26	31		instr Shift
64	65	66	67	20		21	22	0	16	20		dec. input z·2 ⁻²⁸ = (16.21) → 20.1
68	69	70	71	36		37	39	0	25	21		(ID ₁) → 21.1
72	73	74	75	39		02	42	0	26	31		Shift
76	77	78	79	42		44	45	0	25	28		(ID ₀) → AR
80	81	82	83									
84	85	86	87									
88	89	90	91									
92	93	94	95									
96	97	98	99									
u0	u1	u2	u3									
u4	u5	u6										

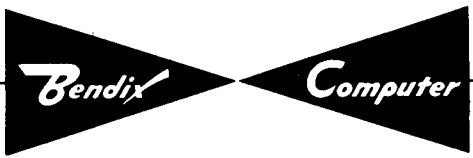

Prepared by S. H. Lewis

Date: 9/18/56

Line 16

G-15 D
PROGRAM PROBLEM :

PPR-D1 (#1000)

0	1	2	3	L	P	T or Lk	N	C	S	D	BP	NOTES
4	5	6	7	45		49	66	0	27	21		$(20 \cdot 21 + \bar{20} \cdot AR)_1 \rightarrow 21.1$
8	9	10	11	51		52	53	0	31	28		$(20 \cdot 21)_0 \rightarrow AR$
12	13	14	15	53	u	58	58	0	28	29		$(AR) \rightarrow AR +$
16	17	18	19	58		59	60	0	16	29		$\Delta = -4238 \vee 38 = (16.59) \rightarrow AR +$
20	21	22	23	60		62	63	0	31	31		N.C. from AR
24	25	26	27	59 \overline{AR} (63)	u	66	56 + 57	6	25	24		$[(ID_0) \xrightarrow{tva} MQ_1, (ID_1) \rightarrow AR]$
28	29	30	31	67		70	82	3	05	28		$\sum (15) = (05.70) \rightarrow AR$ $\text{\textcircled{V}}$
32	33	34	35	68		69	72	0	26	21		$0 = (PN_1) \rightarrow 21.1$ $\text{\textcircled{W}}$
36	37	38	39	69		73	77	0	16	29		$z600000 = (16.73) \rightarrow AR +$ $\text{\textcircled{X}}$
40	41	42	43	70	u	71	08	0	17	19		$(17) \rightarrow 19$ $\text{\textcircled{Y}}$
44	45	46	47	71	u	72	u6	0	17	19		$(17) \rightarrow 19$ $\text{\textcircled{Z}}$
48	49	50	51	72		73	74	0	28	27		$(AR) \rightarrow test$ $\text{\textcircled{W}}$
52	53	54	55	74		90	61	0	05	21		$(05.90) \rightarrow 21.2$ $\text{\textcircled{W00}}$
56	57	58	59	75		76	77	0	16	29		$zu00000 = (16.76) \rightarrow AR +$
60	61	62	63	77		79	79	0	29	31		Overflow $\rightarrow test$ $\text{\textcircled{X}}$
64	65	66	67	79		80	81	3	05	29		$20w3xy4 = (05.80) \rightarrow AR +$
68	69	70	71	80		81	00	0	17	31		Ring Bell
72	73	74	75	81		83	83	0	31	31		N.C. from AR \leftarrow
76	77	78	79	\overline{AR} (83)		85	60	0	16	28		$[(16.85 + b_x) \rightarrow AR]$
80	81	82	83	85 \overline{AR} (63)	u	64	00	1	26	18		$0 = (PN_{0,1}) \xrightarrow{+} 18$ $\left\{ \begin{array}{l} \text{from AR} \\ \text{at 63} \end{array} \right\}$ $\text{\textcircled{X00}}$
84	85	86	87	86 \overline{AR} (63)	u	64	64	1	26	18		$0 = (PN_{0,1}) \xrightarrow{+} 18$ $\left\{ \begin{array}{l} \text{from AR} \\ \text{at 63} \end{array} \right\}$ $\text{\textcircled{X01}}$
88	89	90	91	64		65	65	1	31	31		N.T. $\rightarrow 18$
92	93	94	95	65		66	69	0	05	28		$6 \cdot 2^{-8} = (05.66) \rightarrow AR$
96	97	98	99	88 \overline{AR} (63)		16	84	0	26	31		Shift $\left\{ \begin{array}{l} \text{From AR} \\ \text{at 63} \end{array} \right\}$ $\text{\textcircled{klx03}}$
u0	u1	u2	u3	84		95	97	0	16	25		$10 \cdot 2^{-24} = (16.95) \rightarrow ID_1$
u4	u5	u6		97		08	u6	0	24	31		Mult.

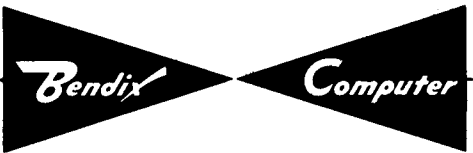

G-15 D
PROGRAM PROBLEM :

PPR-DI

(#1000)

Line 16

0	1	2	3	L	P	T or L _k	N	C	S	D	BP	NOTES
4	5	6	7	u6		05	11	1	17	25		$2^{-24} = (17.05) \xrightarrow{+} ID_1$
8	9	10	11	11		08	25	0	24	31		Mult.
12	13	14	15	25		27	32	3	26	28		$(PN_1) \xrightarrow{-} AR$
16	17	18	19	32		41	43	0	05	29		$5 \cdot 2^{-28} = (05.41) \rightarrow AR + \left\{ \begin{array}{l} klx03 \\ cont'd \end{array} \right\}$
20	21	22	23	43		44	49	0	28	27		$(AR) \rightarrow test [5-D]$
24	25	26	27	44		45	48	0	22	31		$(T_1 \cdot AR) \rightarrow test [15-D]$
28	29	30	31	48		49	55	3	28	28		$(AR) \xrightarrow{-} AR$
32	33	34	35	49		50	00	0	17	31		Ring Bell
36	37	38	39	50		62	44	0	05	29		$u \cdot 2^{-28} = (05.62) \rightarrow AR +$
40	41	42	43	55		57	60	0	16	29		$400024z = (16.57) \rightarrow AR +$
44	45	46	47	[60		62	63	0	31	31]	[N.C. from AR]
48	49	50	51	[^{AR} (63) u		64	00	0	18	(kl)]	[(18) \rightarrow kl]
52	53	54	55	⁸⁷ [(^{AR} (63)]		65	u1	0	05	25		$10 \cdot 2^{-19} = (05.65) \rightarrow ID_1$ From AR at 63
56	57	58	59									[klijx02]
60	61	62	63	u1		08	05	0	24	31		Mult.
64	65	66	67	05		33	35	1	05	25		$2^{-19} = (05.33) \xrightarrow{+} ID_1$
68	69	70	71	35		08	46	0	24	31		Mult.
72	73	74	75	46		47	52	0	16	28		$4046012 = (16.47) \rightarrow AR$
76	77	78	79	52		53	56	0	24	21		$(MQ_1) \rightarrow 21.1$
80	81	82	83	56		57	60	0	26	29		$(PN_1) \rightarrow AR +$
84	85	86	87	[60		62	63	0	31	31]	[N.C. from AR]
88	89	90	91	[^{AR} (63) u		64	70	0	(kl)	18]	[(kl) \rightarrow 18]
92	93	94	95	⁸⁹ [(^{AR} (63)]		12	78	0	26	31		Shift From AR at 63 [cijxo4]
96	97	98	99	78		96	99	6	16	25		$2^{-16} = (16.96) \xrightarrow{tva} ID_1$
u0	u1	u2	u3	99		04	u5	0	24	31		Mult.
u4	u5	u6		u5		05	09	1	05	25		$10 \cdot 2^{-12} = (05.05) \xrightarrow{+} ID_1$

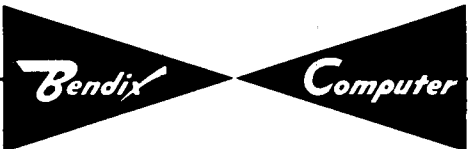

G-15 D

PROGRAM PROBLEM :

PPR-D1

(#1000)

Line 16

0	1	2	3	L	P	T or L _k	N	C	S	D	BP	NOTES
4	5	6	7	09		08	18	0	24	31		Mult.
8	9	10	11	18		25	27	1	05	25		$2^{-12} = (05.25) \xrightarrow{+} ID_1$
12	13	14	15	27		08	54	0	24	31		Mult. [cijx04 (cont'd)]
16	17	18	19	54		55	56	0	05	28	-	$80002vz = (05.55) \rightarrow AR$
20	21	22	23	[56		57	60	0	26	29]	[(PN ₁) → AR ⁺
24	25	26	27	[60		62	63	0	31	31]	[N.C. from AR]
28	29	30	31	[AR (63)	w	00	(ij)	(c)	21	31]	[N.C. from c.i.j]
32	33	34	35	90 [AR (63)		94	61	0	05	21		FROM AR ⁺ } (05.94) → 21.2 [w01,x05] (05.98) → 21.2 [w02,x06] (05.u2) → 21.2 [w03,x07] (16.98) → 21.2 [w04,x08]
36	37	38	39	91 [AR (63)		98	61	0	05	21		
40	41	42	43	92 [AR (63)		78	61	0	05	21		
44	45	46	47	93 [AR (63)		98	08	0	16	21		
48	49	50	51	22		23	24	0	16	28		$y \cdot 2^{-28} = (16.23) \rightarrow AR$ [Dec. Input]
52	53	54	55	24		25	26	3	31	29		$(20 \cdot 21)_1 \xrightarrow{-} AR +$
56	57	58	59	26		29	31	0	16	20		$00zzzzz = (16.29) \rightarrow 20.1$
60	61	62	63	31		32	33	0	28	27		(AR) → test
64	65	66	67	{ 33	u	34	35	0	17	19		(17) → 19 (y)
68	69	70	71	{ 34		37	38	3	16	29		$3 \cdot 2^{-28} = (16.37) \xrightarrow{-} AR + (\bar{y})$
72	73	74	75	38		39	40	0	28	27		(AR) → test
76	77	78	79	{ 40	u	41	41	0	15	19		(15) → 19 (y)
80	81	82	83	{ 41		42	00	0	17	31		Ring Bell (v+y)
84	85	86	87	28								0000z00
88	89	90	91	29								-00zzzzz
92	93	94	95	30								7z00000
96	97	98	99	82	u	83	83	1	15	29		(15) $\xrightarrow{+}$ AR+ (y)
u0	u1	u2	u3	83		84	u3	0	28	27		(AR) → test
u4	u5	u6										

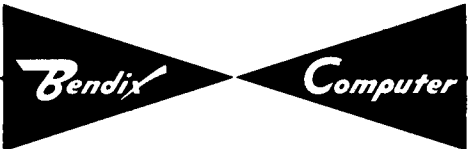

Los Angeles 45, California

Page 25 of 34

Prepared by S. H. Lewis

Date: 9/21/56

G-15 D

PROGRAM PROBLEM : PPR-D1

(#1000)

Line 16

0	1	2	3	L	P	T or L _k	N	C	S	D	BP	NOTES
4	5	6	7	{u3	u	u4	u4	0	15	19		(15) → 19
8	9	10	11	{u4		u5	00	0	17	31		Ring Bell
12	13	14	15	08		09	12	3	05	28		$\Sigma(14) = (05.09) \rightarrow AR$ w04, x08
16	17	18	19	12	u	13	16	1	14	29		(14) ⁺ → AR +
20	21	22	23	16		17	61	0	28	27		(AR) → test
24	25	26	27	{61		63	63	5	21	31		N.C. from 05
28	29	30	31	{62		63	00	0	17	31		Ring Bell
32	33	34	35	21								000000z
36	37	38	39	95								00000u0
40	41	42	43	14								0000v00
44	45	46	47	23								000000y
48	49	50	51	76								zu00000
52	53	54	55	73								z600000
56	57	58	59	37								0000003
60	61	62	63	66		68	51	4	30	25		$(20 \cdot 21)_{0,1} \rightarrow ID_{0,1}$
64	65	66	67	94		64	00	0	17	31		Ring Bell AR 63 w05, x09
68	69	70	71	57								400024z
72	73	74	75	47								4046012
76	77	78	79	96								0001000
80	81	82	83	63								2831000
84	85	86	87	98	u	u4	02	0	14	19		(14) → 19 from AR at u3
88	89	90	91									
92	93	94	95									
96	97	98	99									
u0	u1	u2	u3									
u4	u5	u6										

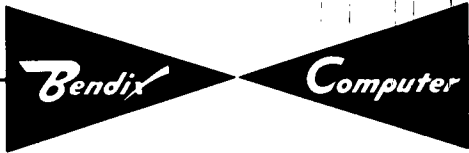

G-15 D

PROGRAM PROBLEM : PPR - D1

(#1000)

Line 17

0	1	2	3	L	P	T or L _k	N	C	S	D	BP	NOTES
4	5	6	7	00	w	00	00	5	21	31		N.C. from 05.00
8	9	10	11	03		12	00	4	00	01		-8w00001 (AR tab format)
12	13	14	15	u6	w	01	08	6	21	31		Mark Return to 01 (Z)
16	17	18	19	08		09	37	0	30	28		(20.21) ₁ → AR (L)
20	21	22	23	37		40	48	3	05	29		u800000 = (05.40) → AR+
24	25	26	27	48		50	50	0	22	31		(T ₁ •AR) → Test
28	29	30	31	{ 50		51	00	0	17	31		Ring Bell
32	33	34	35	{ 51		03	11	0	05	03		4400000 = (05.03) → 03.3
36	37	38	39	{ 11		13	10	1	17	31		Punch Switch → test
40	41	42	43	{ 10		12	13	0	08	31		Type AR [CR]
44	45	46	47	13		39	63	0	05	23		6062000 = (05.39) → 23.3
48	49	50	51	63		65	61	0	30	24		(20.21) ₁ → MQ ₁
52	53	54	55	61		03	85	0	23	03		(23.3) → 03.03
56	57	58	59	{ 85		85	85	0	28	31		Ready ?
60	61	62	63	{ 86		88	u2	6	05	25		10•2 ⁻⁴ = (05.88) ^{tva} → ID ₁
64	65	66	67	u2		u3	u5	0	24	28		(MQ ₁) → AR
68	69	70	71	{ u5		u7	u4	1	17	31		Punch Switch → Test
72	73	74	75	{ u4		u6	01	0	08	31		Type AR (ab)
76	77	78	79	01		08	32	0	24	31		Mult.
80	81	82	83	32		u1	15	1	05	25		2 ⁻⁴ = (05.u1) → ID ₁
84	85	86	87	15		08	34	0	24	31		Mult.
88	89	90	91	34		37	71	0	05	30		805x332 = (05.37) → PN ₁ †
92	93	94	95	{ 71		71	71	0	28	31		Ready ?
96	97	98	99	{ 72		73	76	0	26	28		(PN ₁) → AR
u0	u1	u2	u3	76		78	82	0	28	21		(AR) → 21.2
u4	u5	u6		82		83	84	0	05	29		0001z2u = (05.83) → AR+

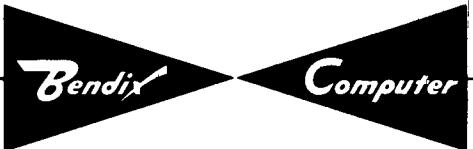

Prepared by S. H. Lewis
 (#1000)

Date: 9-20-56

Line 17

G-15 D
 PROGRAM PROBLEM : PPR-D1

0	1	2	3	L	P	T or L _k	N	C	S	D	BP	NOTES
4	5	6	7	84		86	86	0	31	31		N.C. from AR
8	9	10	11	[AR (86)]	w	(ab)	95	0	18	28		[(18.ab) → AR]
12	13	14	15	95		96	98	0	28	27		(AR) → test
16	17	18	19	97		97	97	0	28	31		Ready ?
20	21	22	23	98		u0	07	5	20	31		Return to 05 (A)
24	25	26	27	99		03	19	0	17	03		-8w00001 = (17.03) → 03.03
28	29	30	31	19		21	18	1	17	31		Punch Switch → test
32	33	34	35	18		20	97	0	08	31		Type AR (18.ab)
36	37	38	39	35		36	39	4	23	24		(23:0,1) → MQ _{0,1} (Y)
40	41	42	43	39		02	42	0	26	31		Shift
44	45	46	47	42	u	45	45	2	24	21		(MQ ₁) ^{tva} → 21.0
48	49	50	51	45		40	87	0	26	31		Shift
52	53	54	55	87		88	91	6	05	25		10·2 ⁻⁴ = (05.88) ^{tva} → ID ₁
56	57	58	59	91		08	u0	0	24	31		Mult. [T ₁₀]
60	61	62	63	u0		u1	u3	1	05	25		2 ⁻⁴ = (05.u1) ⁺ → ID ₁
64	65	66	67	u3		08	04	0	24	31		Mult. [T ₁]
68	69	70	71	04		05	06	1	05	25		10·2 ⁻¹² = (05.05) ⁺ → ID ₁
72	73	74	75	06		07	09	0	26	20		T = (PN ₁) → 20.03
76	77	78	79	09		04	14	0	24	31		Mult. [N' ₁₀]
80	81	82	83	14		15	17	0	24	21		(MQ ₁) → 21.03
84	85	86	87	17		04	22	0	24	21		Mult. [N ₁₀]
88	89	90	91	22		23	24	0	30	21		(20.21) ₃ → 21.03 [T ₂₂ = 1 if d, T even]
92	93	94	95	24		25	27	1	05	25		2 ⁻¹² = (05.25) ⁺ → ID ₁
96	97	98	99	27		10	38	0	24	31		Mult. [N ₁]
u0	u1	u2	u3	38		40	41	0	23	28		(23.0) → AR
u4	u5	u6		41		43	43	0	22	31		(T ₁ ·AR) → test

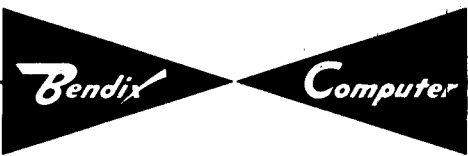

0	1	2	3	L	P	T or L _k	N	C	S	D	BP	NOTES
4	5	6	7	43		45	46	0	27	21		(20.21 + 20.AR) ₁ → 21.1
8	9	10	11	44		47	43	0	17	30		2 ⁻⁹ = (17.47) → PN ₁ +
12	13	14	15	46		47	49	1	05	25		2 ⁻²⁸ = (05.47) + → ID ₁
16	17	18	19	49		02	52	0	24	31		Mult [s/d]
20	21	22	23	52		53	55	1	05	25		2 ⁻¹⁶ = (05.53) + → ID ₁
24	25	26	27	55		04	60	0	24	31		Mult. [ch]
28	29	30	31	60		61	62	0	24	28		(MQ ₁) → AR
32	33	34	35	62		63	64	3	16	29		2831000 = (16.63) - → AR+
36	37	38	39	64		65	67	1	05	25		10 · 2 ⁻¹⁹ = (05.65) + → ID ₁
40	41	42	43	67		68	69	0	28	22		(AR) → 22.0 [o if S28, D31]
44	45	46	47	69		08	78	0	24	31		Mult. [S ₁₀]
48	49	50	51	78		79	81	1	05	25		2 ⁻¹⁹ = (05.79) + → ID ₁
52	53	54	55	81		08	90	0	24	31		Mult. [S ₁]
56	57	58	59	90		91	92	0	24	28		(MQ ₁) → AR
60	61	62	63	92		93	94	0	05	29		wz00000 = (05.93) → AR+ [overflow if D = 31]
64	65	66	67	94		95	96	1	16	25		10 · 2 ⁻²⁴ = (16.95) + → ID ₁
68	69	70	71	96	w	u0	u1	6	21	31		Set return to u0
72	73	74	75	u1		08	02	0	24	31		Mult. [D ₁₀]
76	77	78	79	02		05	07	1	17	25		2 ⁻²⁴ = (17.05) + → ID ₁
80	81	82	83	07		08	16	0	24	31		Mult. [D ₁]
84	85	86	87	16		18	23	3	05	28		W · 2 ⁻²⁰ = (05.18) - → AR
88	89	90	91	23		24	25	0	31	29		P · 2 ⁻²⁰ = (20.21) ₀ → AR+
92	93	94	95	25		26	30	0	28	27		(AR) → test [p-w]
96	97	98	99	29		33	40	0	17	30		9500000 = (17.33) → PN ₁ +
u0	u1	u2	u3	30		53	58	0	17	30		2 ⁻¹ = (17.53) → PN ₁ +
u4	u5	u6		31		33	56	0	05	29		2 ⁻¹⁹ = (05.33) → AR+

To pg 29

To pg 29

To pg 29

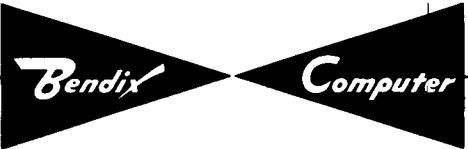

Prepared by S. H. Lewis

Date: 9/21/56

G-15 D
PROGRAM PROBLEM :

PPR-D1

(#1000)

Line 17

0	1	2	3	L	P	T or L _k	N	C	S	D	BP	NOTES
4	5	6	7	56		57	58	0	28	27		(AR) → test [p-u]
8	9	10	11	40		51	54	0	31	30		(20·21) ₃ → PN ₁ +
12	13	14	15	54		56	57	0	29	31		overflow → test ON if t' = u8
16	17	18	19	57		61	66	0	05	30		6w00000 = (05.61) → PN ₁ +
20	21	22	23	58	u	61	70	6	26	23		(PN ₁) → tva → 23.00
24	25	26	27	59		61	65	0	29	31		overflow → test D31
28	29	30	31	65		67	68	0	20	28		T = (20.03) → AR
32	33	34	35	66	u	69	70	6	26	23		(PN ₁) → tva → 23.00
36	37	38	39	68		71	12	0	05	20		2 ⁻⁸ = (05.71) → 20.03
40	41	42	43	12		14	20	3	31	29		L = (20.21) ₂ → AR +
44	45	46	47	20		23	26	3	20	29		2 ⁻⁸ = (20.03) → AR +
48	49	50	51	26		27	29	0	28	27		(AR) → test T-(L+1) To pg. 28
52	53	54	55	70		72	73	0	22	27		(22.00) → test
56	57	58	59	73		52	75	6	05	20		z·2 ⁻⁸ = (05) → tva → 20.01
60	61	62	63	74		76	77	0	23	28		(23.0) → AR (Z)
64	65	66	67	77		78	80	4	28	25		(AR) → ID _{0,1}
68	69	70	71	80		82	84	0	21	28		(21.2) → AR
72	73	74	75	84		86	86	0	31	31		N.C. from AR
76	77	78	79	AR (86)	w	(ab)	93	0	25	18		(ID) → 18·ab
80	81	82	83	93		94	99	0	25	28		(ID) → AR
84	85	86	87	75		77	79	0	31	28		(20·21) ₁ → AR
88	89	90	91	79		82	83	3	05	29		9·2 ⁻⁸ = (05.82) → AR +
92	93	94	95	83		85	88	0	22	31		(T ₁ ·AR) → test
96	97	98	99	88		u1	21	0	05	29		2 ⁻⁴ = (05.u1) → AR +
u0	u1	u2	u3	89		u7	21	0	17	29		u·2 ⁻⁸ = (17.u7) → AR +
u4	u5	u6		21		25	28	0	30	29		(20·21) ₁ → AR -

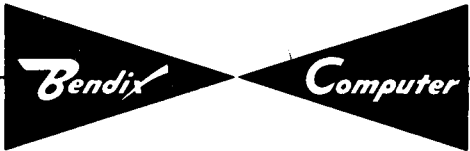

Los Angeles 45, California

Page 30 of 34

Prepared by S. H. Lewis
(#1000)

Date: 9/21/56

G-15 D
PROGRAM PROBLEM : PPR-D1

Line 17

				L	P	T or L _k	N	C	S	D	BP	NOTES
0	1	2	3									
4	5	6	7	28		29	36	0	16	20		-00zzzzz = (16.29) → 20.1
8	9	10	11	36		37	74	0	28	21		(AR) → 21.1 [→ z]
12	13	14	15	05								0000010
16	17	18	19	47								2 ⁻⁹ = 0080000
20	21	22	23	33								9500000
24	25	26	27	53								8000000
28	29	30	31	u7								0u00000
32	33	34	35									
36	37	38	39									
40	41	42	43									
44	45	46	47									
48	49	50	51									
52	53	54	55									
56	57	58	59									
60	61	62	63									
64	65	66	67									
68	69	70	71									
72	73	74	75									
76	77	78	79									
80	81	82	83									
84	85	86	87									
88	89	90	91									
92	93	94	95									
96	97	98	99									
u0	u1	u2	u3									
u4	u5	u6										

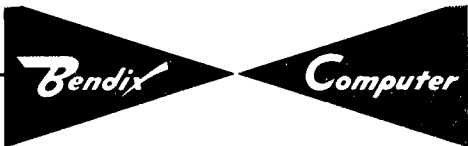

G-15 D

Prepared by Williams

PROGRAM PROBLEM : PPR=D1

Decimal to Binary (#1000)

0	1	2	3	L	P	T or L _k	N	C	S	D	BP	NOTES
4	5	6	7	00		00	00	5	21	31		Transfer to Prog. Start
8	9	10	11	u4		u5	u6	0	15	20		Extractor Set-up
12	13	14	15	u6		01	04	0	31	28		Store s/d flag in 2003
16	17	18	19	04		11	16	0	28	20		
20	21	22	23	16		17	30	0	28	27		AR = 0
24	25	26	27	30		34	91	0	23	31		Yes - single - clear
28	29	30	31	31		37	42	0	15	20		No - double
32	33	34	35	42		45	62	0	31	28		Extract even/odd bit from location and test
36	37	38	39	62		63	88	0	28	27		
40	41	42	43	88		91	91	0	23	31		even-ok, clear
44	45	46	47	89		90	00	0	17	31		odd - ring bell and return
48	49	50	51	91		92	v2	6	15	20		Extractor in 2001
52	53	54	55	u2		u4	01	4	26	23		Clear 2300,1 (duplicate)
56	57	58	59	01	u	02	08	0	17	19		L 17 19, to L type out
60	61	62	63	41		44	46	0	23	31		Clear
64	65	66	67	46		48	51	4	23	24		2300, 1 → MQ _{0,1}
68	69	70	71	51		52	55	5	15	25		10 ¹³ + → ID _{0,1}
72	73	74	75	55		10	65	0	24	31		
76	77	78	79	65		66	69	5	15	25		10 ¹² → ID _{0,1}
80	81	82	83	69		08	79	0	24	31		
84	85	86	87	79		80	83	5	15	25		10 ¹¹
88	89	90	91	83		08	93	0	24	31		
92	93	94	95	93		94	97	5	15	25		10 ¹⁰
96	97	98	99	97		08	u7	0	24	31		
u0	u1	u2	u3	u7		44	23	5	15	25		10 ⁹
u4	u5	u6		03		08	13	0	24	31		

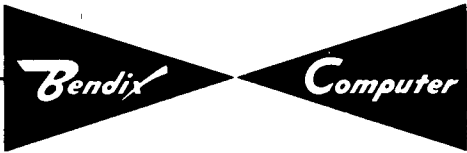

Los Angeles 45, California

Page 32 of 34

Date: 10/11/56

G-15 D

Prepared by Williams

Line 15

PROGRAM PROBLEM : PPR-D1

Decimal to Binary (#1000)

0	1	2	3	L	P	T or L _k	N	C	S	D	BP	NOTES
4	5	6	7	13		14	17	5	15	25		10 ⁸
8	9	10	11	17		08	27	0	24	31		
12	13	14	15	27		28	29	1	15	25		10 ⁷ (single precision)
16	17	18	19	29		08	39	0	24	31		
20	21	22	23	39		40	43	1	15	25		10 ⁶
24	25	26	27	43		08	56	0	24	31		
28	29	30	31	56		58	59	1	15	25		10 ⁵
32	33	34	35	59		08	71	0	24	31		
36	37	38	39	71		72	73	1	15	25		10 ⁴
40	41	42	43	73		08	85	0	24	31		
44	45	46	47	85		86	87	1	15	25		10 ³
48	49	50	51	87		08	99	0	24	31		
52	53	54	55	99		u0	u1	1	15	25		10 ²
56	57	58	59	u1		08	05	0	24	31		
60	61	62	63	05		06	07	1	15	25		10 ¹
64	65	66	67	07		08	19	0	24	31		
68	69	70	71	19		20	21	1	15	25	}	10 ⁰
72	73	74	75	21		08	32	0	24	31		
76	77	78	79	32		33	36	0	15	20	}	
80	81	82	83	36		37	38	0	31	28		
84	85	86	87	38		39	44	0	20	27		Test single/double
88	89	90	91	44		45	47	0	28	27		Single test AR = 0
92	93	94	95	45		46	49	0	28	27		Double test AR = 0
96	97	98	99	47		54	57	1	15	25		single/fr. 10 ⁸ 12 ^{-28t} → ID
u0	u1	u2	u3	48		52	68	0	26	23		single/integer PN ₀ → 2300
u4	u5	u6		57		57	08	1	25	31		Divide

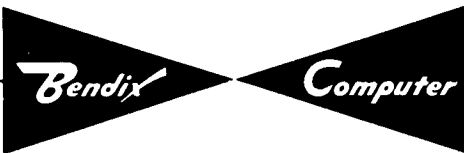

Los Angeles 45, California

Page 33 of 34

Date: 10/11/56

Line 15

G-15 D

Prepared by Williams

PROGRAM PROBLEM :

PPR-D1

Decimal to Binary (#1000)

0	1	2	3	L	P	T or Lk	N	C	S	D	BP	NOTES
4	5	6	7	08		10	10	0	29	31		Test o'flow
8	9	10	11	10		24	68	0	24	23		No -----MQ ₀ → 2300
12	13	14	15	11		12	88	0	17	31		Yes, ring bell, L type out
16	17	18	19	49		60	63	5	15	25		10 ¹⁴ 2 ⁻⁵⁷⁺ + → ID _{0,1}
20	21	22	23	50		52	74	4	26	24		PN _{0,1} → MQ _{0,1}
24	25	26	27	63		76	74	1	25	31	}	Divide
28	29	30	31	74		75	76	0	15	28		Store number
32	33	34	35	76		78	82	0	31	29		Double precision
36	37	38	39	82		84	84	0	31	31		in 18 LL
40	41	42	43	(AR)		LL	98	4	24	18		
44	45	46	47	98		03	09	0	17	03		Load Format (Tab)
48	49	50	51	09		10	12	0	24	28		MQ ₀ → AR
52	53	54	55	12		22	22	0	08	31		Type AR
56	57	58	59	22		22	22	0	28	31		Ready test
60	61	62	63	23		25	26	4	24	28		MQ ₁ → AR
64	65	66	67	26		28	34	0	08	31		Type AR
68	69	70	71	34		34	34	0	28	31		Ready test
72	73	74	75	35		37	00	0	15	21		"clear" mode and return
76	77	78	79	68		69	70	0	15	21		"clear" mode
80	81	82	83	70	u	71	74	0	17	19		L 17 → L 19; to putaway
84	85	86	87									and type result
88	89	90	91									
92	93	94	95									
96	97	98	99									
u0	u1	u2	u3	06						u0		10 ¹ 2 ⁻²⁴
u4	u5	u6		20						10		10 ⁰ 2 ⁻²⁴

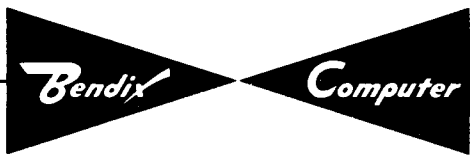

G-15 D

Prepared by Williams

PROGRAM PROBLEM :

PPR-D1

Decimal to Binary (#1000)

0	1	2	3	L	P	T or L _k	N	C	S	D	BP	NOTES
4	5	6	7	u5						40		See 15u4
8	9	10	11	37			1	0	00	00		See 36
12	13	14	15	92				z	zz	zz	-	91
16	17	18	19	33						10		32
20	21	22	23	54			5z	5	y1	00		47
24	25	26	27	60			07	u	40	00	}	49
28	29	30	31	61			00	2	x7	98	-}	10 ¹⁴ 2 ⁻⁵⁷
32	33	34	35	75		00	98	4	24	18		74
36	37	38	39	52			y5	4	00	00	}	10 ¹³ 2 ⁻⁵²
40	41	42	43	53			00	9	18	4y	}	
44	45	46	47	66			u5	1	00	00	}	10 ¹² 2 ⁻⁵³
48	49	50	51	67			00	0	74	6u	}	
52	53	54	55	80			76	y	80	00	}	10 ¹¹ 2 ⁻⁵³
56	57	58	59	81					v	u4	}	
60	61	62	63	94			v	y	40	00	}	10 ¹⁰ "
64	65	66	67	95					l	2u	}	
68	69	70	71	24			9	u	wu	000	}	10 ⁹ "
72	73	74	75	25						lx	-}	
76	77	78	79	14			z5	y	10	00	}	10 ⁸ "
80	81	82	83	15						2	-}	
84	85	86	87	28			98	9	68	00		10 ⁷ 2 ⁻²⁴
88	89	90	91	40			z	4	24	00		10 ⁶ "
92	93	94	95	58			1	8	6u	00		10 ⁵ "
96	97	98	99	72					2	71	00	10 ⁴ "
u0	u1	u2	u3	86					3y	80		10 ³ "
u4	u5	u6		u0					6	40		10 ² "