

## **Chapter 4**

---

### **1374 User- Installable Options**



---

---

# 1374 USER-INSTALLABLE OPTIONS

---

---

---

## INTRODUCTION

---

This chapter introduces the user-installable options available for the 1374 family of control units. These options consist of printed circuit boards (PCBs), diskette drives, and software. This chapter is divided into the following sections:

- **1374 Model 1L/1R/2R/3R** – This section briefly describes the options available for the 0X series control units. Step-by-step installation instructions for all associated hardware are provided.
- **1374 Model 41R/42R/43R** – This section briefly describes the options available for the 4XR series control units. Step-by-step installation instructions for all associated hardware are provided.
- **1374 Model 51R/52R/53R** – This section briefly describes the options available for the 5XR series control units. Step-by-step installation instructions for all associated hardware are provided.
- **1374 Model 61R** – This section briefly describes the options available for the 61R control unit. Step-by-step installation instructions for all associated hardware are provided.
- **1374 Model 71R/72R/73R** – This section briefly describes the options available for the 7XR series control units. Step-by-step installation instructions for all associated hardware are provided.

---

## 1374 MODEL 1L/1R/2R/3R

---

### INTRODUCTION

In addition to the standard features provided by the 1374-0X series control units, Memorex Telex offers several options that may be installed by the user.

These options are described in the following sections:

- **Dual-Host Options** – This section introduces the Dual IBM SNA/SDLC Host Option, Dual Mixed (SNA/SDLC and BSC) IBM Host Option, Dual SNA Local and SNA/SDLC Remote IBM Host Option, and Dual Host/Token-Ring Gateway Option. Installation instructions for all hardware required for these options are provided.
- **Second Disk Drive** – This section describes the second disk drive. Installation instructions for the second disk drive are provided.
- **Coax Extender Adapter** – This section describes the 16-port Coax Extender Adapter. Installation instructions for the 16-Port Coax Extender Adapter are provided.

## 1374 USER-INSTALLABLE OPTIONS

- **Asynchronous Adapter** – This section describes the Asynchronous Adapter. Installation instructions for the Asynchronous Adapter are provided.
- **Memory Expansion Modules** – This section describes the 1-MByte and 512-KByte Memory Expansion Modules. Installation instructions for the Memory Expansion Modules are provided.
- **Token-Ring Gateway** – This section describes the Token-Ring Gateway for model 1L/1R/2R control units. Installation instructions for the Token-Ring Gateway are provided.
- **Functional Conversions** – This section describes how to convert on control unit model to function as a different control unit model (e.g., converting a model 1L to function as a model 1R).

### OPTIONS BOARD CONFIGURATION

OX series control units have a 9-slot board assembly that accommodates eight full-size boards and two half-size boards.

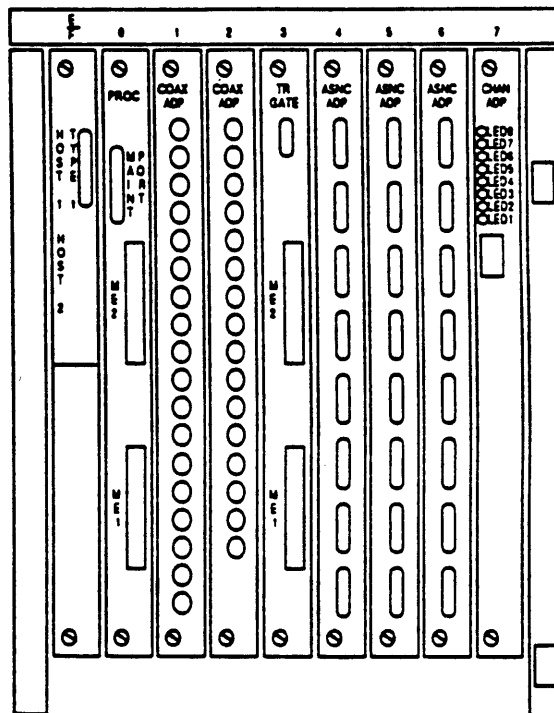

Figure 4-1. View of a Fully Populated Model 1L

**SLOT E:** Host Serial Interface (for Dual Local/Remote Host support)

**SLOT 0:** Processor PCB

## **1374 USER-INSTALLABLE OPTIONS**

---

**SLOT 1:** Coax Adapter (ports 0 through 15)

**SLOT 2:** Sixteen-Port Coax Extender Adapter (ports 16 through 31)

**SLOT 3:** Asynchronous Adapter (ports 32 through 39)

**SLOT 4:** Asynchronous Adapter (ports 40 through 47)

**SLOT 5:** Asynchronous Adapter (ports 48 through 55)

**SLOT 6:** Token-Ring Gateway

**SLOT 7:** High-Speed Channel Adapter

### **DUAL-HOST OPTION**

#### **DUAL IBM SNA/SDLC HOST OPTION**

The Dual IBM SNA/SDLC Host option provides concurrent support for two IBM SNA/SDLC host links on model 1R and 2R control units. This option requires an additional full-function serial interface. This additional serial interface is provided by installing a Host Serial Interface Extender, type 1 or 2, (HSIE1 for RS 232C/V.35 or HSIE2 for X.21). Operational software for this option is contained on the system diskette.

#### **DUAL MIXED (SNA/SDLC AND BSC) IBM HOST OPTION**

The Dual Mixed (SNA/SDLC and BSC) IBM Host option provides concurrent support for an IBM SNA/SDLC host and an IBM BSC host on model 1R and 2R control units. This option requires use of a special system diskette and an additional full-function serial interface in the control unit. This additional serial interface is provided by installing the Host Serial Interface Extender, type 1 or 2, (HSIE1 for RS 232C/V.35 or HSIE2 for X.21).

#### **HOST SERIAL INTERFACE EXTENDER**

Dual-Host hardware consists of a Host Serial Interface Extender (HSIE1 or HSIE2) installed in the Host Serial Interface PCB. To install the HSIE PCB, perform the following steps:

- STEP 1:** Switch control unit power off and disconnect the power cord from the rear of the control unit.
- STEP 2:** Open the bottom door of the control unit and remove the HSIE filler panel. It is located in the Host Serial Interface PCB installed in slot E.
- STEP 3:** Insert and seat the HSIE into the slot and tighten the thumb screws.

## 1374 USER-INSTALLABLE OPTIONS

---

**STEP 4:** Connect the modem cable for the second host to the HSIE.

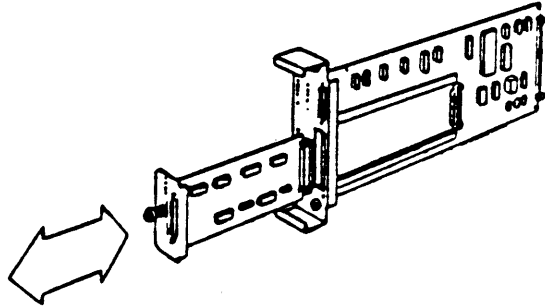

**Figure 4-2.** Installing the Host Serial Interface Extender

**STEP 5:** Reconnect the power cord and IML the control unit.

After the power-on switch or IML button is pressed, the following events occur if the control unit is working correctly.

- The codes "P080" and then "P081" momentarily appear in the front panel indicators. These indicate the self-test process.
- The disk drive indicator lights up and the diskette loads software into 1374 memory.
- After about 45 seconds, the disk access light goes out and the control unit is operational.

Any code remaining in the front panel indicators during testing or operation indicates a failure. Contact a service representative to correct the error condition.

**STEP 6:** Configure the control unit for the additional host.

---

### **DUAL SNA LOCAL AND SNA/SDLC REMOTE IBM HOST OPTION**

This option is available for 1L Model 2 control units and 1L Model 1 control units with the 80386-based processor installed. Refer to Chapter 1, "Introduction," in this manual and the *1374 Troubleshooting Guide* for additional information about the 80386-based processor. This option supports one locally attached IBM or compatible System/370 host and one remotely attached host. The local host link is attached to a byte multiplexer, block multiplexer, or selector channel of the host processor and provides single-tag interlocked and two-tag high-speed transfer channel-operation modes.

## 1374 USER-INSTALLABLE OPTIONS

The remote link attachment requires an RS 232C/V.35 interface or an X.21 interface. The RS 232C/V.35 interface provides the same remote support as the model 1R, while the X.21 interface provides the same remote support as the model 2R. This option requires the installation of the Host Serial Interface (HSI1 for RS 232C/V.35 or HSI2 for X.21) PCB.

### HOST SERIAL INTERFACE EXTENDER

Dual SNA Local and SNA/SDLC Remote IBM Host hardware consists of a Host Serial Interface Extender (HSIE1 or HSIE2) installed in a model 1L control unit.

To install the HSIE PCB, perform the following steps:

- STEP 1:** Switch control unit power off and disconnect the power cord from the rear of the control unit.
- STEP 2:** Open the bottom door of the control unit and remove the HSIE filler panel. It is located in slot E.
- STEP 3:** Insert and seat the HSI into the slot and tighten the thumb screws.
- STEP 4:** Connect the modem cable for the remote host to the HSIE.

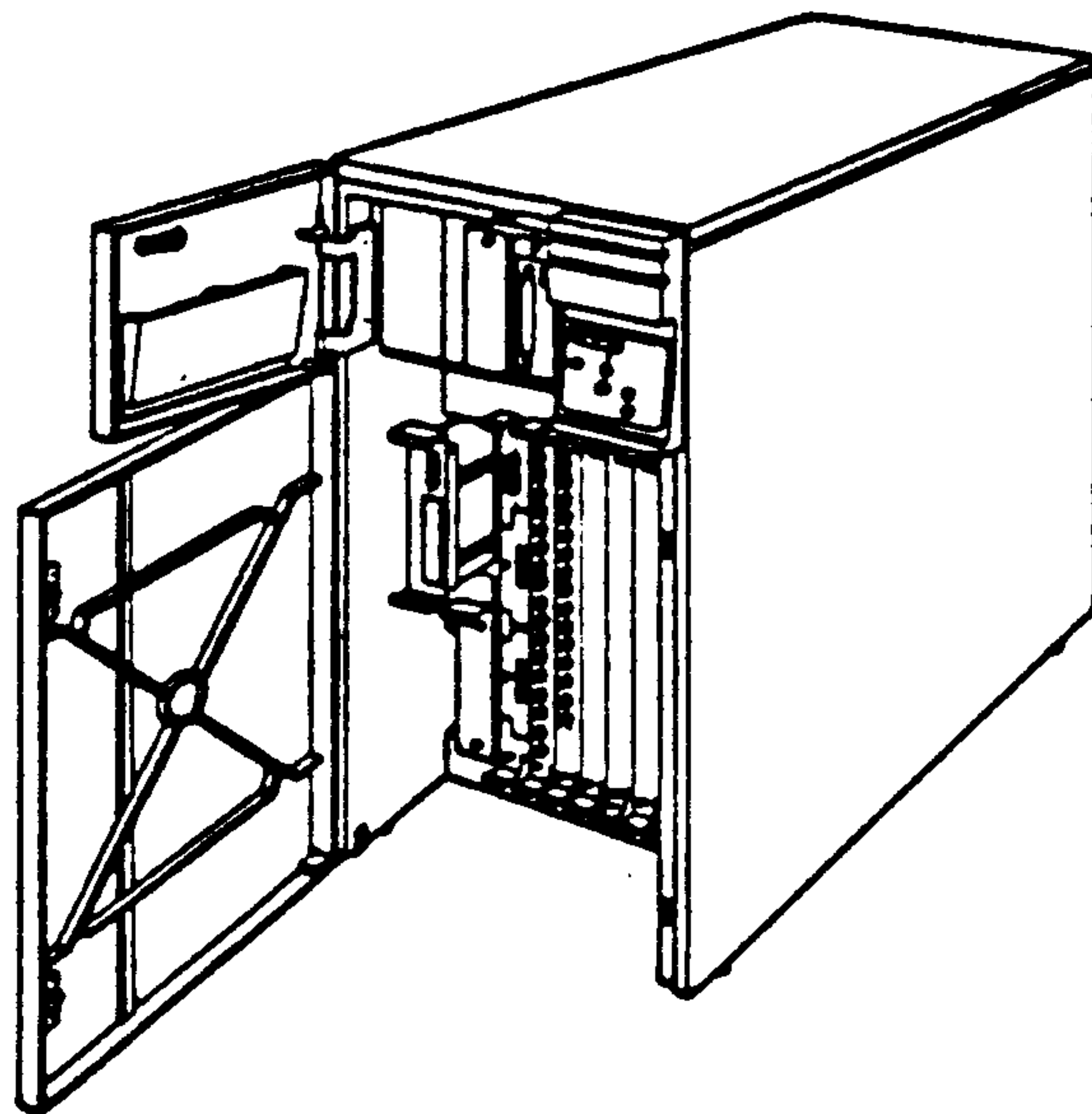

**Figure 4-3. Installing the Host Serial Interface Extender**

- STEP 5:** Reconnect the power cord and IML the control unit.

After the power-on switch or IML button is pressed, the following events occur if the control unit is working correctly.

## 1374 USER-INSTALLABLE OPTIONS

- The codes "P080" and then "P081" momentarily appear in the front panel indicators. These indicate the self-test process.
- The disk drive indicator lights up and the diskette loads software into 1374 memory.
- After about 45 seconds, the disk access light goes out and the control unit is operational.

Any code remaining in the front panel indicators during testing or operation indicates a failure. Contact a service representative to correct the error condition.

**STEP 6:** Configure the control unit for the additional host.

### DUAL HOST AND TOKEN-RING GATEWAY OPTION

This option is available for the model 1L/1R/2R control units. The model 1L control unit must be a 1L Model 2, or a 1L Model 1 with the 80386-based processor installed. Refer to Chapter 1, "Introduction," in this manual or to the *1374 Troubleshooting Guide* for additional information about the 80386-based processor.

The model 1L control unit supports one SNA local channel-attached link and one SNA/SDLC remote link in addition to the Token-Ring Gateway. Models 1R and 2R support two SNA/SDLC remote links in addition to the Token-Ring Gateway.

This option requires installation of the Token-Ring Gateway PCB. Instructions for installing the Token-Ring Gateway are provided later in this chapter.

### SECOND DISK DRIVE

The second disk drive is required to support Downstream Load (DSL) terminals and Asynchronous Communications Support (ACS). This disk drive can also be used for disk copy backup. The DSL and ACS diskettes can be placed in either disk drive.

The second disk drive consists of a single component that slides into the control unit next to the standard disk drive.

### INSTALLATION

To install the second disk drive, perform the following steps:

**STEP 1:** Switch control unit power off and disconnect the power cord from the rear of the control unit.

**STEP 2:** Open the top door of the control unit and remove the filler panel from the second disk drive slot.

## 1374 USER-INSTALLABLE OPTIONS

---

**STEP 3:** Insert the second disk drive into the slot along the card guides and tighten the thumb screws.

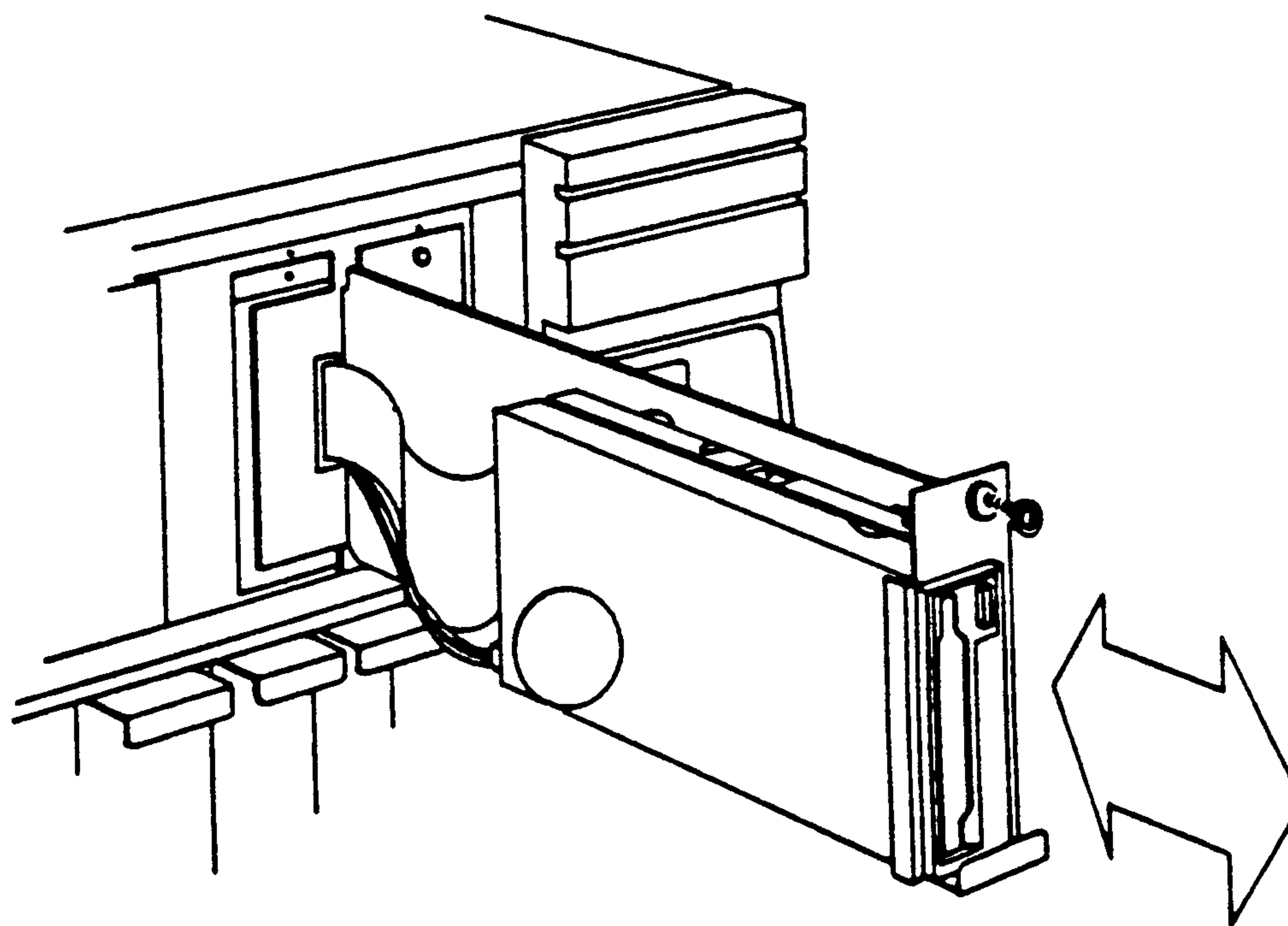

**Figure 4-4.** Installing the Second Disk Drive

**STEP 4:** Reconnect the power cord and IML the control unit.

After the power-on switch or IML button is pressed, the following events occur if the control unit is working correctly.

- The codes "P080" and then "P081" momentarily appear in the front panel indicators. These indicate the self-test process.
- The disk drive indicator lights up and the diskette loads software into 1374 memory.
- After about 45 seconds the access light goes out and the control unit is operational.

Any code remaining in the front panel indicators during testing or operation signals a failure. Contact a service representative to correct the error condition.

---

### **16-PORT COAX EXTENDER ADAPTER**

Installing the 16-port Coax Extender Adapter PCB allows 0X series control units to support 32 directly attached coax devices. The extender has dual-purpose connectors that support the IBM cabling system. This PCB also supports 8-port coax multiplexers. Attached devices, when used with the IBM cabling system, do not require the use of baluns at the controller or device end of the cable.

## 1374 USER-INSTALLABLE OPTIONS

---

### CONFIGURATION

Configuring the additional coax ports available with this option is performed through the LCP facility.

### INSTALLATION

To install the Coax Extender Adapter, perform the following steps:

**STEP 1:** Switch control unit power off and disconnect the power cord from the rear of the control unit.

**STEP 2:** Open the bottom door of the control unit and remove a filler panel.

**NOTE:** The 16-Port Coax Extender Adapter must be installed in the next higher-numbered slot immediately adjacent to the coax adapter. As an example, if the coax adapter is installed in slot 2, install the 16-port Coax Extender Adapter in slot 3.

**STEP 3:** Insert the 16-port Coax Extender Adapter into the slot along the card guides and tighten the thumb screws.

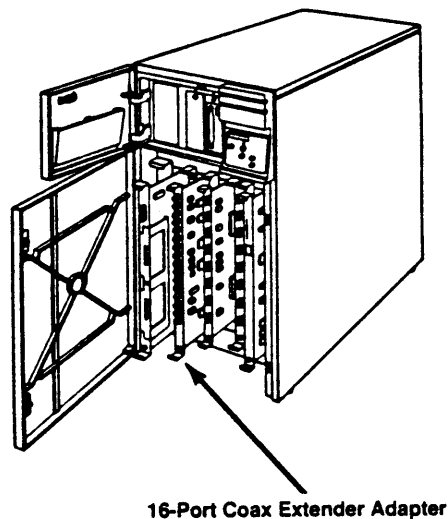

**Figure 4-5. Installing the 16-Port Coax Extender**

**STEP 4:** Reconnect the power cord and IML the control unit.

After the power-on switch or IML button is pressed, the following events occur if the control unit is working correctly.

## 1374 USER-INSTALLABLE OPTIONS

---

- The codes "P080" and then "P081" momentarily appear in the front panel indicators. These indicate the self-test process.
- The disk drive indicator lights up and the diskette loads software into 1374 memory.
- After about 45 seconds the disk access light goes out and the control unit is operational.

Any code remaining in the front panel indicators during testing or operation indicates a failure. Contact a service representative to correct the error condition.

**STEP 5:** Attach the coax devices to the 16-port Coax Extender Adapter.

**STEP 6:** Configure the control unit for the additional coax devices.

### ASYNCHRONOUS ADAPTER

The Asynchronous Adapter provides the physical connection for ASCII devices and hosts. It is used in connection with Asynchronous Communications Support (ACS). Each Asynchronous Adapter provides eight asynchronous ports. Installing three adapters allows OX series control units to support a total of 24 asynchronous devices or hosts.

The Asynchronous Adapter Option supports RS 232C and RS 422A interfaces through a 15-pin D-sub female connector.

### CONFIGURATION

Configuring the A/A ports supplied with this option is performed through the LCP (CO) facility.

### ASYNCHRONOUS ADAPTER PORT ADDRESSING

Facing the front of the control unit, the leftmost installed Asynchronous Adapter starts asynchronous port numbering at 32. All Asynchronous Adapter PCBs have eight ports labeled 0 - 7.

### INSTALLATION

To install the Asynchronous Adapter, perform the following steps:

**STEP 1:** Switch control unit power off and disconnect the power cord from the rear of the control unit.

**STEP 2:** Open the bottom door of the control unit and remove the filler panel from the desired option slot.

## 1374 USER-INSTALLABLE OPTIONS

---

**STEP 3:** Insert and seat the Asynchronous Adapter into the slot along the card guides and tighten the thumb screws.

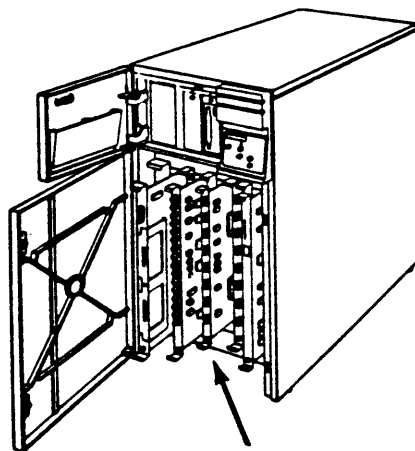

**Asynchronous Adapter**

**Figure 4-6. Installing the Asynchronous**

**NOTE:** Before performing step 4, the ACS Diskette and second disk drive must be installed in the control unit.

**STEP 4:** Reconnect the power cord and IML the control unit.

After the power-on switch or IML button is pressed, the following events occur if the control unit is working correctly.

- The codes "P080" and then "P081" momentarily appear in the front panel indicators. These indicate the self-test process.
- The disk drive indicator lights up and the diskette loads software into 1374 memory.
- After about 45 seconds the disk access light goes out and the control unit is operational.

Any code remaining in the front panel indicators during testing or operation indicates a failure. Contact a service representative to correct the error condition.

**STEP 5:** Attach the asynchronous devices to the Asynchronous Adapter.

**STEP 6:** Configure the control unit for the A/A devices.

### 1-MBYTE AND 512-KBYTE MEMORY EXPANSION MODULES

The 1-MByte and 512-KByte Memory Expansion Modules provide 0X series control units additional memory expansion of up to 3.5 MBytes. The standard memory installed in these control units is 1.5 MBytes.

The Memory Expansion Modules slide into vertical slots on the left side of the Processor PCB.

### INSTALLATION

To install a Memory Expansion Module, perform the following steps:

**STEP 1:** Switch control unit power off and disconnect the power cord from the rear of the control unit.

**STEP 2:** Open the bottom door of the control unit and locate the two vertical slots on the left side of the Processor PCB.

**STEP 3:** Install the first Memory Expansion Module into the slot labeled "ME1."

**NOTE:** If you are installing only one Memory Expansion Module, it must be installed in the slot labeled "ME1."

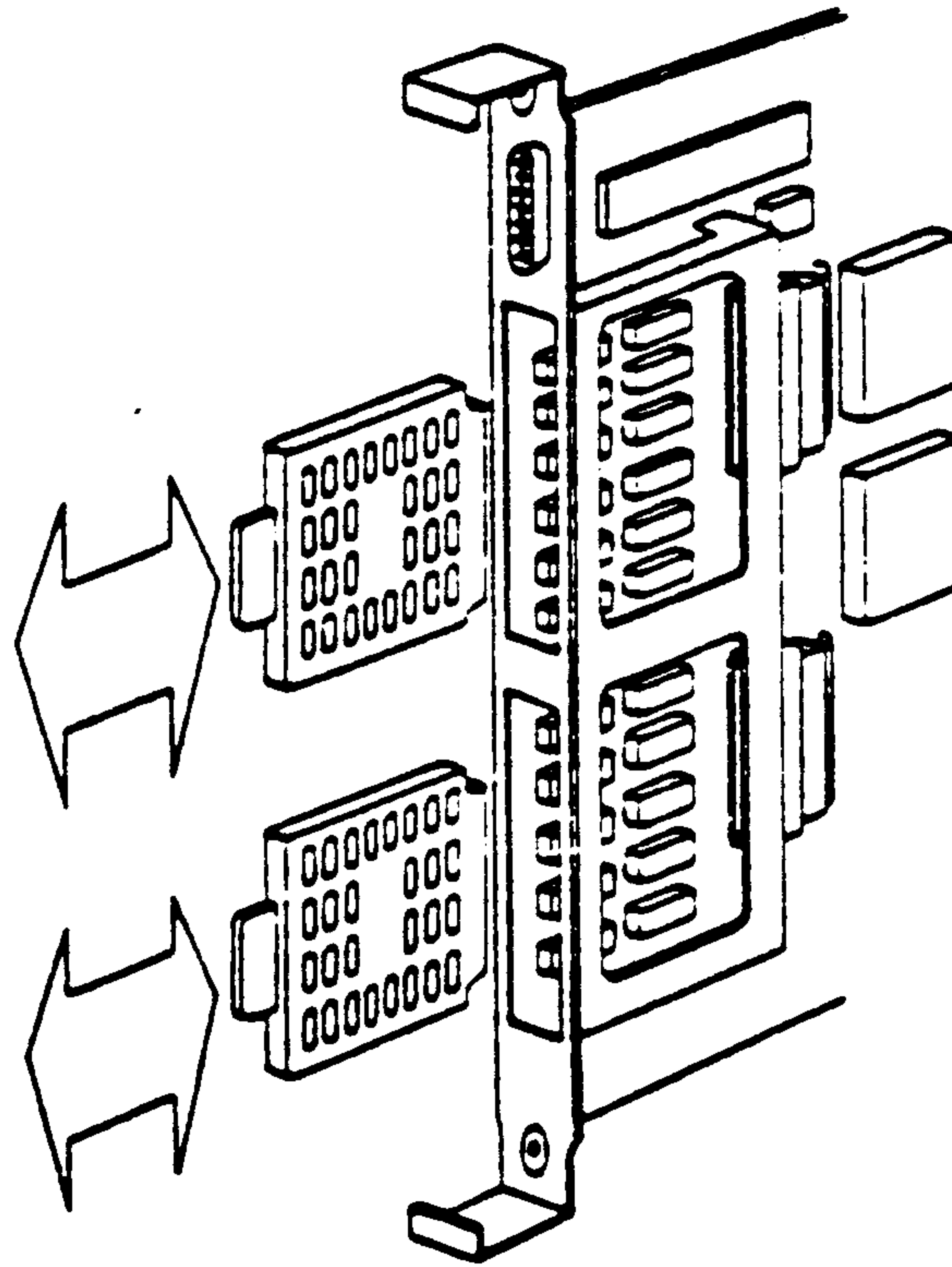

**Figure 4-7. Installing Memory Board Expansions in the PROC PCB**

## 1374 USER-INSTALLABLE OPTIONS

---

**STEP 4:** Reconnect the power cord and IML the system.

After the power-on switch or IML button is pressed, the following events occur if the control unit is working correctly.

- The codes "P080" and then "P081" momentarily appear in the front panel indicators. These indicate the self-test process.
- The disk drive indicator lights up and the diskette loads software into 1374 memory.
- After about 45 seconds the disk access light goes out and the control unit is operational.

Any code remaining in the front panel indicators during testing or operation indicates a failure. Contact a service representative to correct the error condition.

### TOKEN-RING GATEWAY

The Token-Ring Gateway provides the physical connection between model 1L/1R/2R control units and the Token-Ring LAN.

#### CONFIGURATION

Configuring the control unit is performed via the LCP facility.

#### INSTALLATION

To install the Token-Ring Gateway, perform the following steps:

- STEP 1:** Switch control unit power off and disconnect the power cord from the rear of the control unit.
- STEP 2:** Open the bottom door of the control unit and remove a filler panel.
- STEP 3:** Insert and seat the Token-Ring Gateway PCB into the slot along the card guides and tighten the thumb screws.
- STEP 4:** Reconnect the power cord and IML the control unit.

After the power-on switch or IML button is pressed, the following events occur if the control unit is working correctly.

- The codes "P080" and then "P081" momentarily appear in the front panel indicators. These indicate the self-test process.
- The disk drive indicator lights up and the diskette loads software into 1374 memory.

## 1374 USER-INSTALLABLE OPTIONS

- After about 45 seconds the disk access light goes out and the control unit is operational.

Any code remaining in the front panel indicators during testing or operation indicates a failure. Contact a service representative to correct the error condition.

**STEP 5:** Attach the Token-Ring Gateway to the multistation access unit.

**STEP 6:** Configure the control unit for Token-Ring LAN support.

### **TOKEN-RING 1-MBYTE AND 512-KBYTE MEMORY EXPANSION MODULES**

The Token-Ring 1-MByte and 512-KByte Memory Expansion PCBs provide additional memory for control units that have the Token-Ring Gateway PCB installed. The additional memory provides support for up to 140 downstream nodes. The next tables show memory requirements for 1L control units and for 1R/2R control units.

<b>Downstream Nodes</b>	<b>Memory Requirements</b>
1 to 40	512 KBytes
41 to 8	21 MByte
83 to 125	1.5 MBytes
126 to 140	2 MBytes

**Table 4-1. 1L Memory Requirements**

<b>Downstream Nodes</b>	<b>Memory Requirements</b>
1 to 40	512 KBytes
41 to 82	1 MByte

**Table 4-2. 1R/2R Memory Requirements**

The Memory Expansion PCBs slide into vertical slots on the Token-Ring Gateway.

### **INSTALLATION**

To install the Memory Expansion PCBs, perform the following steps:

**STEP 1:** Switch control unit power off and disconnect the power cord from the rear of the control unit.

## 1374 USER-INSTALLABLE OPTIONS

---

**STEP 2:** Open the bottom door of the control unit and locate the two vertical slots on the Token-Ring Gateway.

**STEP 3:** Install the first Memory Expansion PCB into the slot labeled "ME1."

**NOTE:** If you are installing one memory expansion card it must be installed in the slot labeled "ME1."

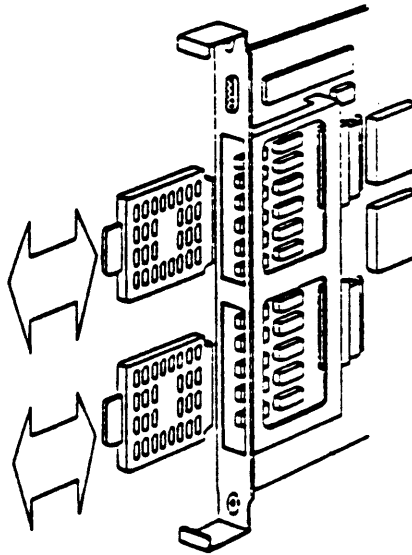

**Figure 4-8. Installing Memory Expansion Modules in TR GATE**

**STEP 4:** Reconnect the power cord and IML the system.

After the power-on switch or IML button is pressed, the following events occur if the control unit is working correctly.

- The codes "P080" and then "P081" momentarily appear in the front panel indicators. These indicate the self-test process.
- The disk drive indicator lights up and the diskette loads software into 1374 memory.
- After about 45 seconds the disk access light goes out and the control unit is operational.

Any code remaining in the front panel indicators during testing or operation indicates a failure. Contact a service representative to correct the error condition.

### FUNCTIONAL CONVERSIONS

The modular hardware design allows various 0X series control units to be easily converted to function as other models (e.g., 1R to 2R).

**NOTE:** The following instructions only describe how to convert control unit models from a functional standpoint. These instructions do not describe how to physically convert the control unit models. EPO functions are not changed, nor are the control unit labels replaced.

### MODEL 1L TO 1R/2R/3R

To convert a model 1L to function as model 1R, 2R or 3R, perform the following steps:

1. Switch control unit power off.
2. If converting to a model 1R or 2R, install the Host Serial Interface Extender 1 (model 1R), Host Serial Interface Extender 2 (model 2R) into the upper half-slot (Slot E). Refer to the relevant section in this chapter for details about installing HSIE PCBs.
3. If converting to a model 3R, remove a full-size stiffener from a vacant PCB slot and install the Token-Ring Adapter into that slot.
4. Insert into the diskette drive the correct system diskette for the model to which the control unit is being converted.
5. Switch control unit power on. When the IML has completed, the control unit will function as the model to which it has been converted.

**NOTE:** Converting a model 1L to a remote unit disables the local (1L) control unit functions when the IML is performed. To disable the remote (1R/2R/3R) functions and return to the local operation, re-IML the control unit with the local system diskette.

### MODEL 1R/2R TO 3R

To convert a model 1R or 2R to a model 3R, install the Token-Ring Adapter as outlined in Step 3 and re-IML the control unit with the model 3R system diskette.

**NOTE:** Converting a model 1R or model 2R to a model 3R disables the remote host functions in the control unit when the IML is performed. To disable the Token Ring functions and return to the control unit to remote host operation, re-IML the control unit the appropriate remote system diskette.

## 1374 USER-INSTALLABLE OPTIONS

---

### MODEL 3R TO 1R/2R

To convert a model 3R to a model 1R or a model 2R, install the correct HSI PCB as described in Step 2 and re-IML the control unit with the correct remote system diskette.

**NOTE:** Converting a model 3R to a model 1R or model 2R disables the token ring functions in the control unit when the IML is performed. To disable the model 1R or 2R functions and return to token ring operation, re-IML the model 3R with the remote system diskette.

### MODEL 1R TO 2R OR 2R TO 1R

To convert a model 1R to a model 2R (or vice versa) simply change the HSIE PCB and re-IML with the correct system diskette. Refer to the relevant section of this chapter for details about installing HSIE PCBs.

---

## 1374 MODEL 41R/42R/43R

---

### INTRODUCTION

In addition to the standard features provided by the 1374 Model 4XR series control units, Memorex Telex offers a second diskette drive and several printed circuit boards (PCBs) that may be installed by the user.

These options are described in the following sections:

- **Dual-Host Options** – This section describes the Dual IBM SNA/SDLC Host Option and the Dual Mixed (SNA/SDLC and BSC) IBM Host Option. Installation instructions for the Host Serial Interface Extender (HSIE) for the models 41R/42R are provided.
- **Second Diskette Drive** – This section describes the installation of the second disk drive.
- **Coax Extender Adapter** – This section describes the installation of the Coax Extender Adapter.
- **Asynchronous Adapter** – This section describes the installation of the Asynchronous Adapter PCB and Connector Panel.
- **Memory Expansion Modules** – This section describes installation of the 1-MByte and 512-KByte Memory Expansion Modules.
- **Token-Ring Gateway** – This section describes the installation of the Token-Ring Gateway.
- **Functional Conversions** – This section describes how to convert on control unit model to function as a different control unit model (e.g., converting a model 41R to function as a model 43R).

### DUAL-HOST OPTION

#### DUAL IBM SNA/SDLC HOST OPTION

The Dual IBM SNA/SDLC Host option provides concurrent support for two IBM SNA/SDLC host links on model 41R and 42R control units. This option requires a second full-function serial interface. The additional serial interface is provided by installing a Host Serial Interface Extender (HSIE1 for RS 232C/V.35 or HSIE2 for X.21). Operational software for this option is contained on the system diskette.

#### DUAL MIXED (SNA/SDLC AND BSC) IBM HOST OPTION

The Dual Mixed (SNA/SDLC and BSC) IBM Host option provides concurrent support for an IBM SNA/SDLC host and an IBM BSC host on model 41R and 42R control units. This option requires installation of a special system diskette and an additional full-function serial interface in the control unit. This additional serial interface is provided by installing a Host Serial Interface Extender (HSIE1 for RS 232C/V.35 or HSIE2 for X.21).

### HOST SERIAL INTERFACE EXTENDER

Dual-Host hardware consists of a Host Serial Interface Extender (HSIE) installed in the control unit. To install the HSIE PCB, perform the following steps:

- STEP 1:** Switch control unit power off and disconnect the power cord from the rear of the control unit.
- STEP 2:** Open the front door and loosen the two screws on the top edge of the control unit. Gently push the top cover back and lift to release it from the chassis.
- STEP 3:** Remove the blank panel covering the Host 2 port. Insert the HSIE from the inside of the chassis and secure with the captive screws on the back panel. Connect ribbon cable P1 on the HSIE to P5 on the Processor PCB.
- STEP 4:** Install the top cover and secure it with the two captive screws located on the top edge of the control unit.
- STEP 5:** After the power-on switch or IML button is pressed, the following events occur if the control unit is working correctly.
- The codes "P080" and then "P081" momentarily appear in the front panel indicators. These indicate the self-test process.
  - The disk drive indicator lights up and the diskette loads software into 1374 memory.

## 1374 USER-INSTALLABLE OPTIONS

---

- After about 25 to 30 seconds the disk access light goes out and the control unit is operational.

Any code remaining in the front panel indicators during testing or operation indicates a failure. Contact a service representative to correct the error condition.

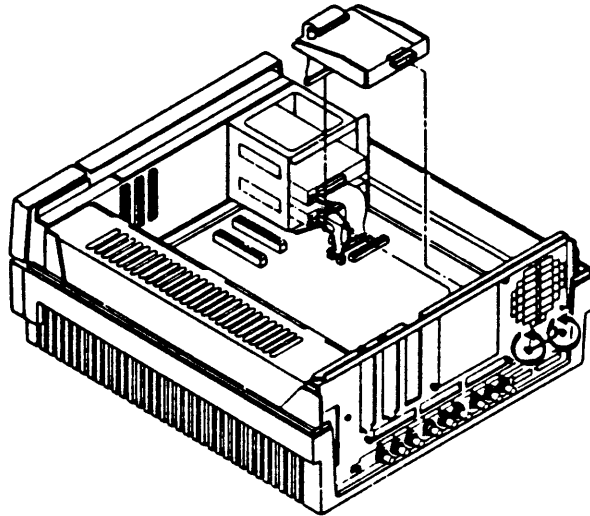

**Figure 4-9. Installing the Host Serial Interface Extender**

**STEP 6:** Configure the control unit for the additional host.

### DUAL-HOST AND TOKEN-RING GATEWAY

This option is available for the model 41R and 42R control units. Models 41R and 42R support two SNA/SDLC remote links in addition to the Token-Ring Gateway.

This option requires installation of the Token-Ring Gateway PCB. Instructions for installing the Token-Ring Gateway are provided later in this chapter.

### SECOND DISK DRIVE

The second disk drive is required to support DownStream Load (DSL) terminals and Asynchronous Communications Support (ACS). This disk drive can also be used for disk copy backup.

The second disk drive consists of a single component that slides into the control unit above the standard disk drive.

### INSTALLATION

To install the second disk drive, perform the following steps:

- STEP 1:** Switch control unit power off and disconnect the power cord from the rear of the control unit.
- STEP 2:** Open the front door and loosen the two screws on the top edge of the control unit. Gently push the top cover back and lift to release it from the chassis.
- STEP 3:** Remove the blank disk drive panel from the front panel. Insert the second disk drive in the top tray of the disk drive housing. Pull out the spring-loaded pin and push the drive into the disk drive housing. Align the front bezel and release the spring-loaded pin to latch the drive into place.

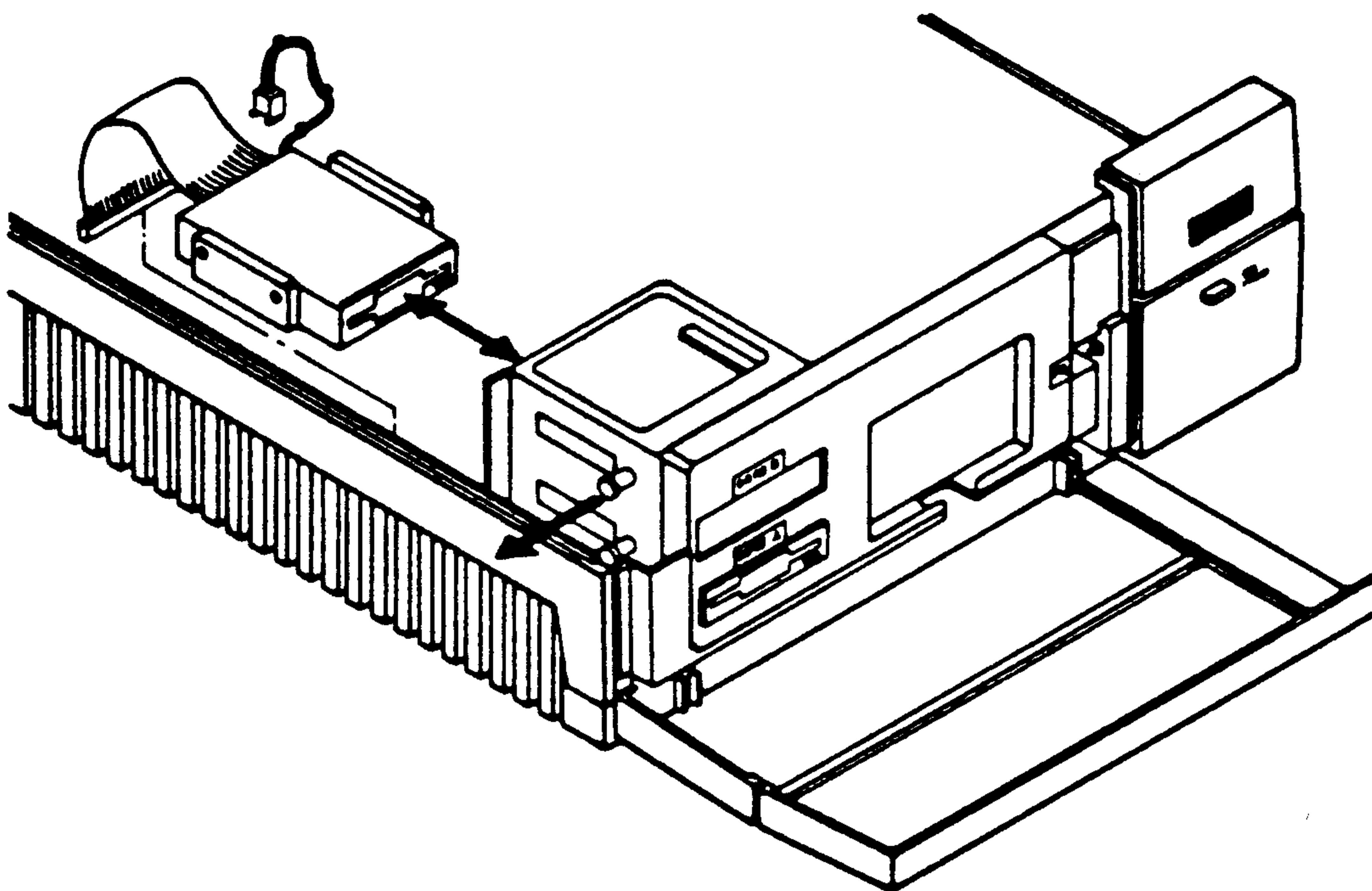

**Figure 4-10.** Installing the Second Disk Drive

- STEP 4:** Connect the ribbon cable to the disk drive connector and the other end of the ribbon cable to connector P3 on the Processor PCB. Ensure a pin 1-to-pin 1 connection. Pin 1 is indicated by the red stripe on the ribbon cable. Connect the power cable assembly to the disk drive connector and the other end of the power cable to P9 on the Processor PCB.
- STEP 5:** Install the top cover and secure with two captive screws located on the top edge of the control unit.
- STEP 6:** Reconnect the power cord and IML the control unit.

## 1374 USER-INSTALLABLE OPTIONS

---

After the power-on switch or IML button is pressed, the following events occur if the control unit is working correctly.

- The codes "P080" and then "P081" momentarily appear in the front panel indicators. These indicate the self-test process.
- The disk drive indicator lights up and the diskette loads software into 1374 memory.
- After about 25 to 30 seconds the disk access light goes out and the control unit is operational.

Any code remaining in the front panel indicators during testing or operation indicates a failure. Contact a service representative to correct the error condition.

### COAX EXTENDER ADAPTER

The Coax Extender Adapter provides the controller with nine additional coax ports.

#### INSTALLATION

To install the Coax Extender Adapter, perform the following steps:

- STEP 1:** Switch the control unit off and disconnect the power cord from the rear of the unit.
- STEP 2:** Open the front door and loosen the two screws on the top edge of the control unit. Gently push the top cover back and lift it from the chassis.
- STEP 3:** Remove the filler panel by loosening the two captive screws on rear panel.
- STEP 4:** Carefully slide the coax extender PCB into the slot on the rear panel from inside the controller chassis.
- STEP 5:** Connect the ribbon cable to P13 on the PROC PCB and tighten the captive screws on the rear panel.
- STEP 6:** Install the top cover and secure it with the two captive screws.
- STEP 7:** Reconnect the power cord and IML the unit.

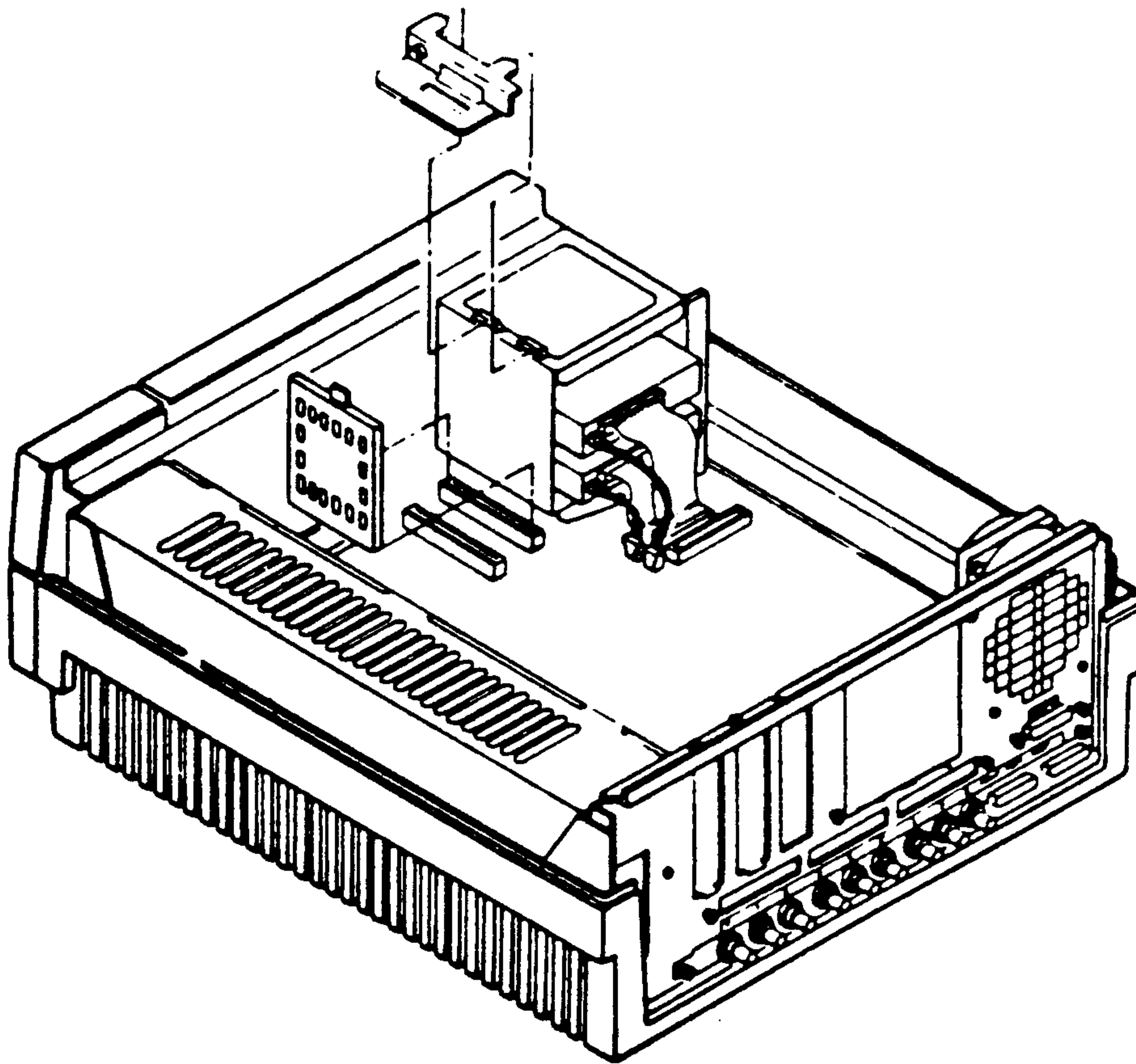

Figure 4-11. Coax Extender Adapter Installation

### ASYNCHRONOUS ADAPTER

The Asynchronous Adapter and the Connector Panel provide the physical connection for ASCII devices and hosts and are used with Asynchronous Communications Support (ACS) software. The 1374 Connector Panel contains eight 25-pin D-Sub connectors. These connectors allow 4XR control units to support a total of eight A/A devices or hosts.

The Connector Panel supports RS 232C and RS 422A interfaces on a port-by-port basis. Selection of the desired interface type is accomplished by setting jumpers (located on the inside of the connector panel) for each port. The factory default setting is for RS 232C operation with the jumpers for each port connecting posts 1 and 2. To operate an asynchronous port with the RS 422A interface, move the jumper to posts 2 and 3. The following list shows the jumper for each port of the connector panel.

## 1374 USER-INSTALLABLE OPTIONS

<u>Asynchronous Adapter Port</u>	<u>Jumper Label</u>
0	JP1
1	JP3
2	JP5
3	JP7
4	JP9
5	JP11
6	JP13
7	JP15

### CONFIGURATION

Configuring the A/A ports supplied with this option is performed via the LCP (CO) facility.

### ASYNCHRONOUS ADAPTER PORT ADDRESSING

The connector module has eight ports labeled 0 - 7. A/A port addressing starts at port 32.

### INSTALLATION

To install the Asynchronous Adapter, perform the following steps:

- STEP 1:** Switch control unit power off and disconnect the power cord from the rear of the control unit.
- STEP 2:** Open the front door and loosen the two screws on the top edge of the control unit. Gently push the top cover back and lift to release it from the chassis.
- STEP 3:** Remove the filler panels for the connector panel and option slot 1. Secure the connector panel to the rear of the control unit with the two captive screws.
- STEP 4:** Insert and seat the Asynchronous Adapter PCB in option slot 1 aligning the front of the PCB in the nylon guide slot and the rear into the back panel. Secure the PCB to the top edge of the back panel with the captive screw.
- STEP 5:** Connect the ribbon cables.

## 1374 USER-INSTALLABLE OPTIONS

Processor PCB	to	Connector Panel PCB
Ribbon cable P2		P1
Ribbon cable P3		P2
Ribbon cable P4		P3

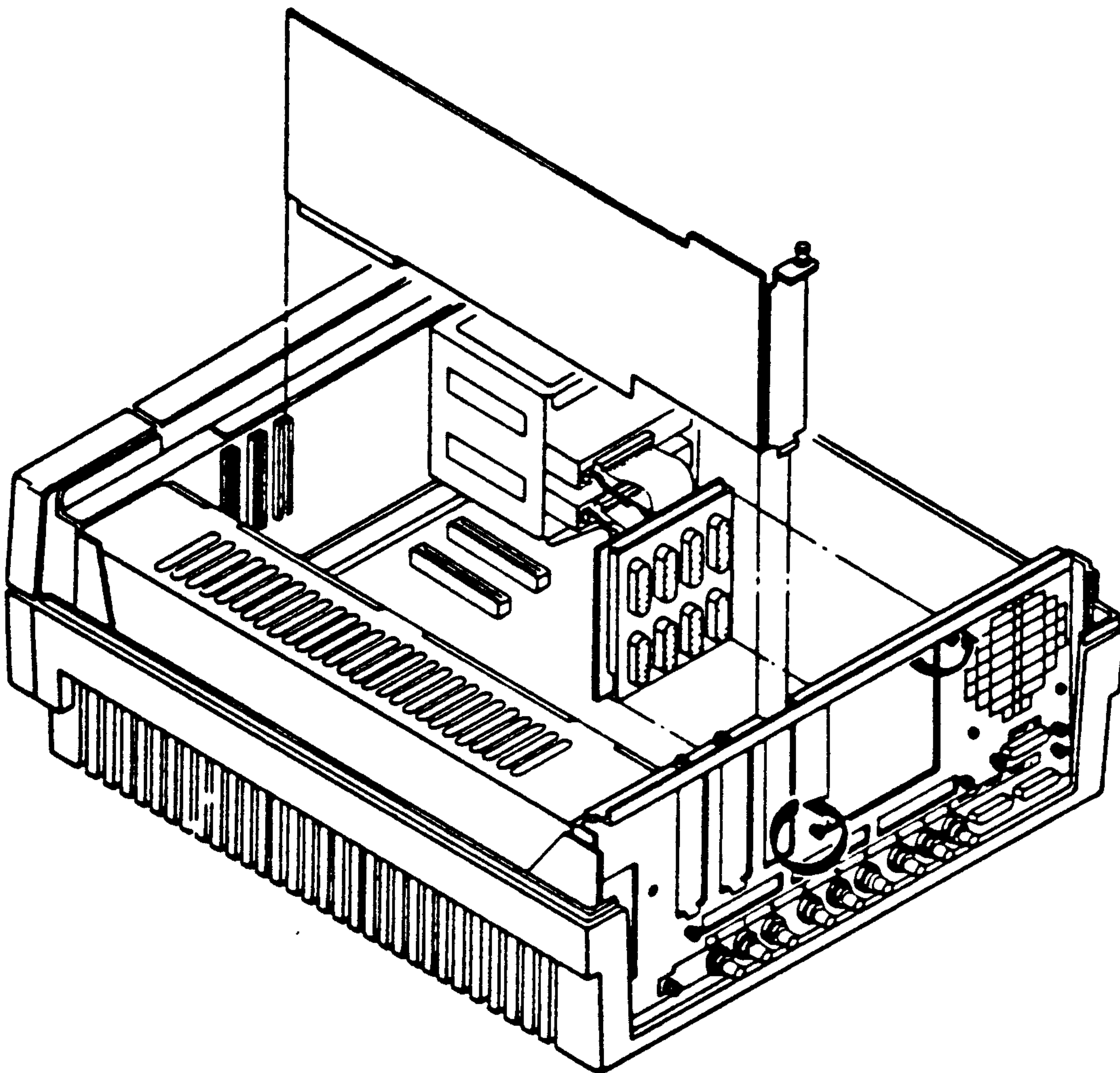

**Figure 4-12. Installing the Asynchronous Adapter**

**STEP 6:** Install the top cover and secure it with the two captive screws located on the top edge of the control panel.

**NOTE:** Before performing step 7, the ACS diskette and second disk drive must be installed in the control unit.

**STEP 7:** Reconnect the power cord and IML the control unit. After the power-on switch or IML button is pressed, the following events occur if the control unit is working correctly.

- The codes "P080" and then "P081" momentarily appear in the front panel indicators. These indicate the self-test process.

## 1374 USER-INSTALLABLE OPTIONS

- The disk drive indicator lights up and the diskette loads software into 1374 memory.
- After about 25 to 30 seconds the disk access light goes out and the control unit is operational.

Any code remaining on the front panel indicators during testing or operation indicates a failure. Contact a service representative to correct the error condition.

**STEP 8:** Attach the asynchronous devices to the connector panel.

**STEP 9:** Configure the control unit for the A/A devices.

### 1-MBYTE AND 512-KBYTE MEMORY EXPANSION MODULES

The 1-MByte and 512-KByte Memory Expansion Modules provide 1374-4XR series control units additional memory expansion of up to 3.5 MBytes. The 4XR control units have a standard 1.5-MByte memory.

The Memory Expansion Modules slide into vertical slots to the right of the disk drive housing.

### INSTALLATION

To install a Memory Expansion Module, perform the following steps:

- STEP 1:** Switch control unit power off and disconnect the power cord from the rear of the control unit.
- STEP 2:** Open the front door and loosen the two screws on the top edge of the control unit. Gently push the top cover back and lift to release it from the chassis.
- STEP 3:** Install the Memory Expansion Module in the first available board connector to the right of the disk drive housing. Install the retaining bracket fingers in the top edge of the disk drive housing and secure with the screw.
- STEP 4:** Install the top cover and secure with two captive screws located on the top edge of the control unit.
- STEP 5:** Reconnect the power cord and IML the system.

After the power-on switch or IML button is pressed, the following events occur if the control unit is working correctly.

- The codes "P080" and then "P081" momentarily appear in the front panel indicators. These indicate the self-test process.

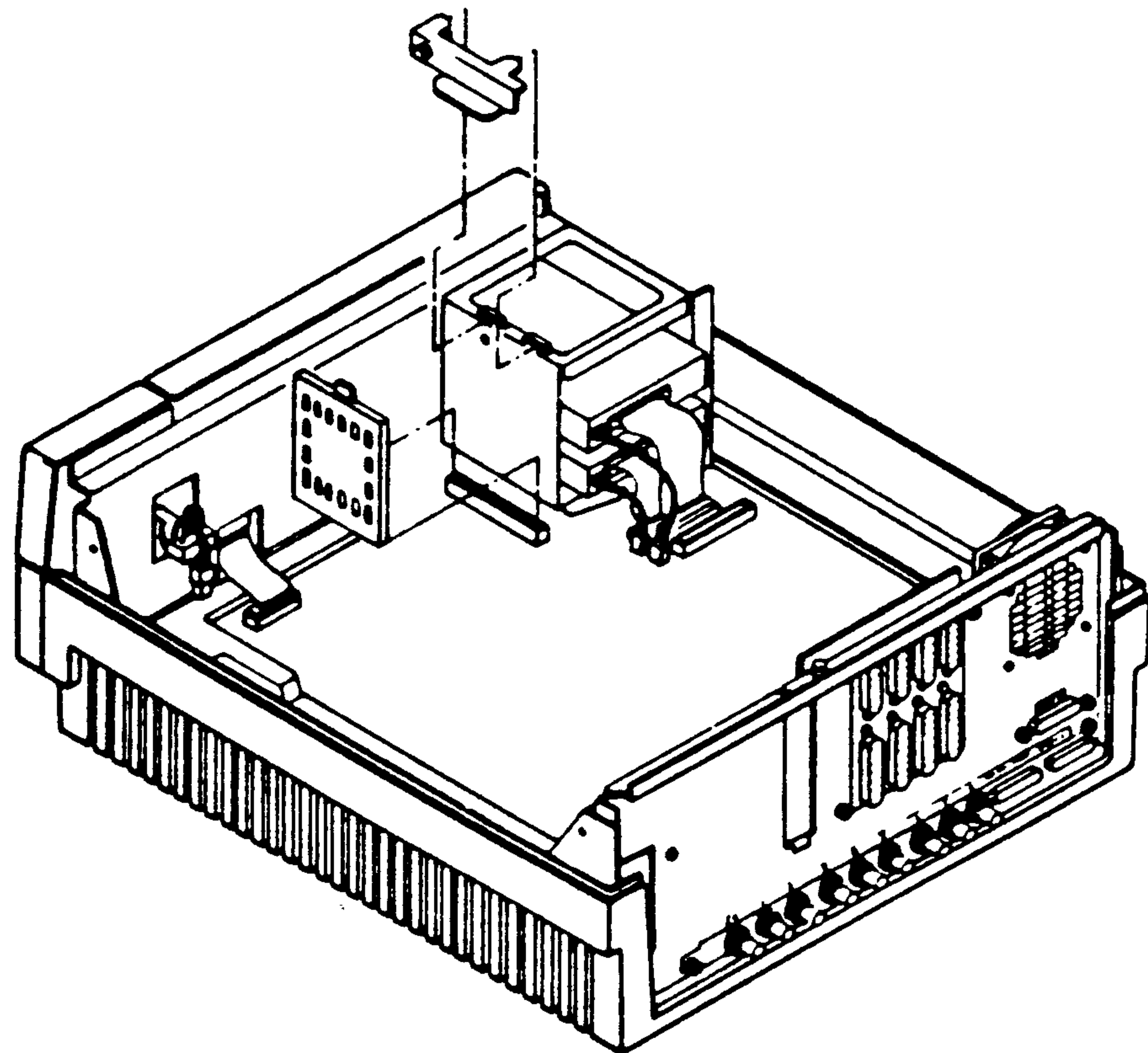

**Figure 4-13. Installing Memory Expansion Modules**

- The disk drive indicator lights up and the diskette loads software into 1374 memory.
- After about 25 to 30 seconds the disk access light goes out and the control unit is operational.

Any code remaining in the front panel indicators during testing or operation indicates a failure. Contact a service representative to correct the error condition.

### TOKEN-RING GATEWAY

The Token-Ring Gateway provides the physical connection between model 41R and 42R control units and the Token-Ring LAN.

### CONFIGURATION

Configuring the control unit is performed via the LCP facility.

### INSTALLATION

To install the Token-Ring Gateway, perform the following steps:

**STEP 1:** Switch control unit power off and disconnect the power cord from the rear of the control unit.

## 1374 USER-INSTALLABLE OPTIONS

---

- STEP 2:** Open the front door and loosen the two screws on the top edge of the control unit. Gently push the top cover back and lift it to release it from the chassis.
- STEP 3:** Locate and remove a blank filler panel for one of the option slots (slot 2 is suggested) in the rear of the control unit.
- STEP 4:** Insert and seat the Token-Ring Gateway PCB into the slot along the card guides and tighten the thumb screw.
- STEP 5:** Replace the top cover.
- STEP 6:** Reconnect the power cord and IML the control unit.

After the power-on switch or IML button is pressed, the following events occur if the control unit is working correctly.

- The codes "P080" and then "P081" momentarily appear in the front panel indicators. These indicate the self-test process.
- The disk drive indicator lights up and the diskette loads software into 1374 memory.
- After about 45 seconds the disk access light goes out and the control unit is operational.

Any code remaining in the front panel indicators during testing or operation indicates a failure. Contact a service representative to correct the error condition.

- STEP 7:** Attach the Token-Ring Gateway to the multistation access unit.
- STEP 8:** Configure the control unit for Token-Ring LAN support.

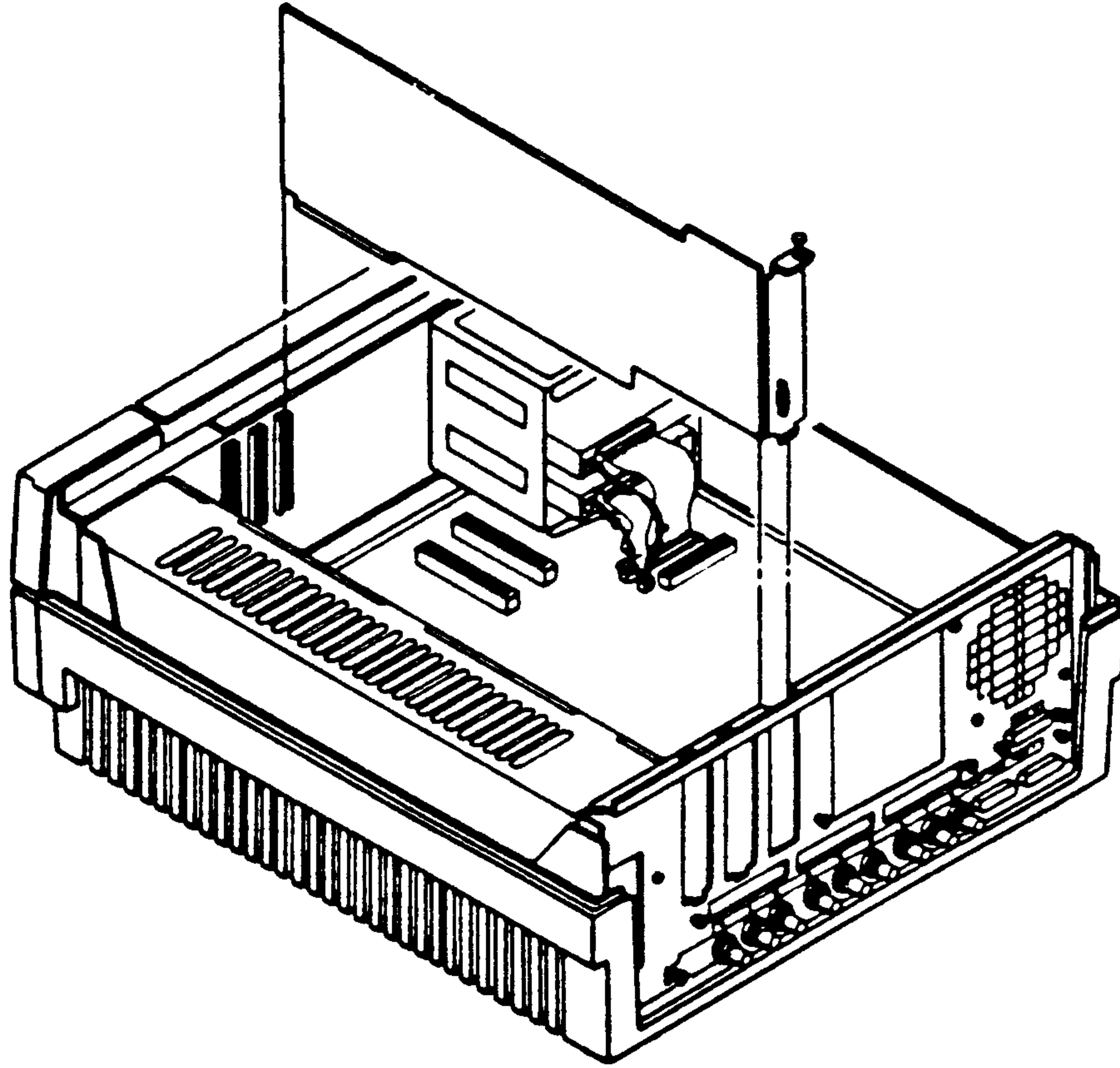

**Figure 4-14. Installing the Token-Ring Gateway**

### FUNCTIONAL CONVERSIONS

Model 41R and 42R control units can be converted to function as Model 43R Token-Ring downstream node control units by installing the Token-Ring Adapter PCB.

To convert a Model 41R or 42R control unit to a Model 43R, perform the following steps:

**STEP 1:** The Token-Ring Adapter is installed in the identical manner as the Token-Ring Gateway. Follow the instructions for installing the Token-Ring Gateway as outlined in the previous two pages.

**STEP 2:** Insert the Model 43R system diskette into the diskette drive.

**STEP 3:** Switch control unit power on. When the IML has completed, the control unit will function as the model to which it has been converted.

**NOTE:** Converting a model 41R or model 42R to a model 43R disables the remote host functions in the control unit when the IML is performed. To disable the Token Ring functions and return to remote host operation, re-IML the control unit with the appropriate remote diskette.

## 1374 USER-INSTALLABLE OPTIONS

---

### 1374 MODEL 51R/52R/53R

---

#### INTRODUCTION

In addition to the standard features provided by the 1374 models 5XR series control units, Memorex Telex offers several options that may be installed by the user.

These options are described in the following sections:

- **Dual-Host Support Options** – This section describes Dual SNA/IBM SDLC Host Support and installation of the Host Serial Interface Extender (HSIE)
- **Second Diskette Drive** – This section describes installation of the second disk drive.
- **Asynchronous Adapter** – This section describes the Asynchronous Adapter and the installation of the Asynchronous Adapter PCB and connector panel.
- **Memory Expansion Modules** – This section describes installation of the 1-MByte and 512-KByte Memory Expansion Modules.
- **Token-Ring Gateway** – This section describes the Token-Ring Gateway for model 51R/52R control units. Installation instructions for the Token-Ring Gateway are provided.
- **Functional Conversions** – This section describes how to convert on control unit model to function as a different control unit model (e.g., converting a model 51R to function as a model 53R).

#### DUAL-HOST OPTION

##### DUAL IBM SNA/SDLC HOST OPTION

The Dual IBM SNA/SDLC Host option provides concurrent support for two IBM SNA/SDLC host links on model 51R and 52R control units. This option requires a second full-function serial interface. The additional serial interface is provided by installing a Host Serial Interface Extender (HSIE1 for RS 232C/V.35 or HSIE2 for X.21). Operational software for this option is contained on the system diskette.

##### HOST SERIAL INTERFACE EXTENDER

Dual-Host hardware consists of a Host Serial Interface Extender (HSIE) installed in the control unit. To install the HSIE PCB, perform the following steps:

- STEP 1:** Switch control unit power off and disconnect the power cord from the rear of the control unit.

## 1374 USER-INSTALLABLE OPTIONS

**STEP 2:** Open the front door and loosen the two screws on the top edge of the control unit. Gently push the top cover back and lift to release it from the chassis.

**STEP 3:** Remove the blank panel covering the Host 2 port. Insert the Host Serial Interface Extender from the inside of the chassis and secure with the captive screws on the outside of the back panel. Connect ribbon cable P1 on the HSIE to P5 on the Processor PCB.

**STEP 4:** Install the top cover and secure it with the two captive screws located on the top edge of the control unit.

**STEP 5:** After the power-on switch or IML button is pressed, the following events occur if the control unit is working correctly.

- The codes "P080" and then "P081" momentarily appear in the front panel indicators. These indicate the self-test process.
- The disk drive indicator lights up and the diskette loads software into 1374 memory.
- After about 25 to 30 seconds the disk access light goes out and the control unit is operational.

Any code remaining in the front panel indicators during testing or operation indicates a failure. Contact a service representative to correct the error condition.

**STEP 6:** Configure the control unit for the additional host.

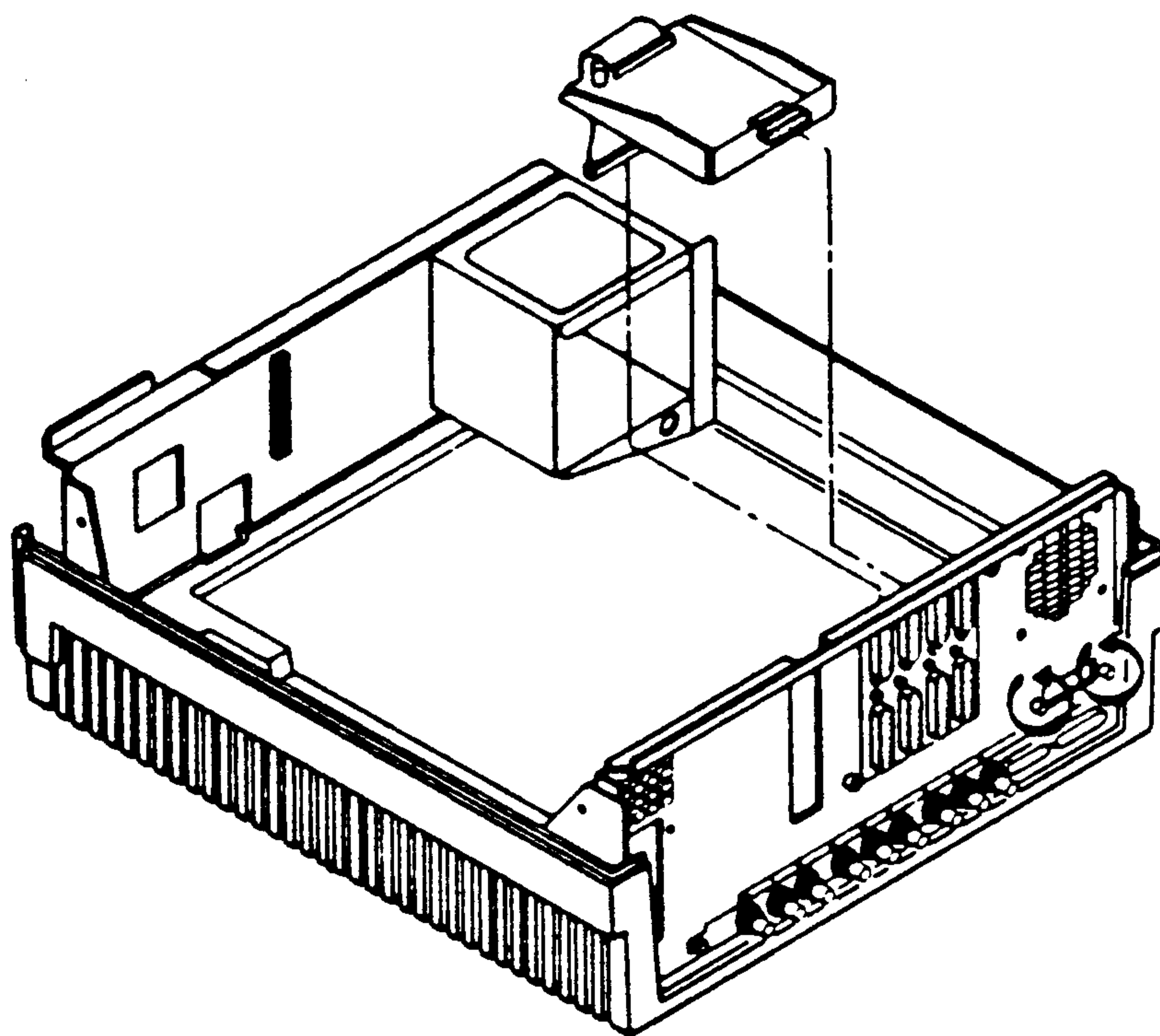

Figure 4-15. Installing the Host Serial Interface Extender

## **1374 USER-INSTALLABLE OPTIONS**

---

### **DUAL-HOST AND TOKEN-RING GATEWAY**

This option is available for the model 51R and 52R control units. Models 51R and 52R support two SNA/SDLC remote links in addition to the Token-Ring Gateway.

This option requires installation of the Token-Ring Gateway PCB. Instructions for installing the Token-Ring Gateway are provided later in this chapter.

### **SECOND DISK DRIVE**

The second disk drive is required to support Downstream Load (DSL) terminals and Asynchronous Communications Support (ACS). This disk drive can also be used for disk copy backup.

The second disk drive consists of a single component that slides into the control unit above the standard disk drive.

### **INSTALLATION**

To install the second disk drive, perform the following steps:

- STEP 1:** Switch control unit power off and disconnect the power cord from the rear of the control unit.
- STEP 2:** Open the front door and loosen the two screws on the top edge of the control unit. Gently push the top cover back and lift to release it from the chassis.
- STEP 3:** Remove the blank disk drive panel from the front panel. Insert the second disk drive in the top tray of the disk drive housing. Pull out the spring-loaded pin and push the drive into the disk drive housing. Align the front bezel and release the spring-loaded pin to latch the drive into place.
- STEP 4:** Connect the ribbon cable to the disk drive connector and the other end of the ribbon cable to connector P3 on the Processor PCB. Ensure a pin 1-to-pin 1 connection. Pin 1 is indicated by a stripe on the ribbon cable. Connect the power cable assembly to the disk drive connector and the other end of the power cable to P9 on the Processor PCB.
- STEP 5:** Install the top cover and secure it with the two captive screws located on the top edge of the control unit. Review installation instructions of other options you are installing before installing the top cover.

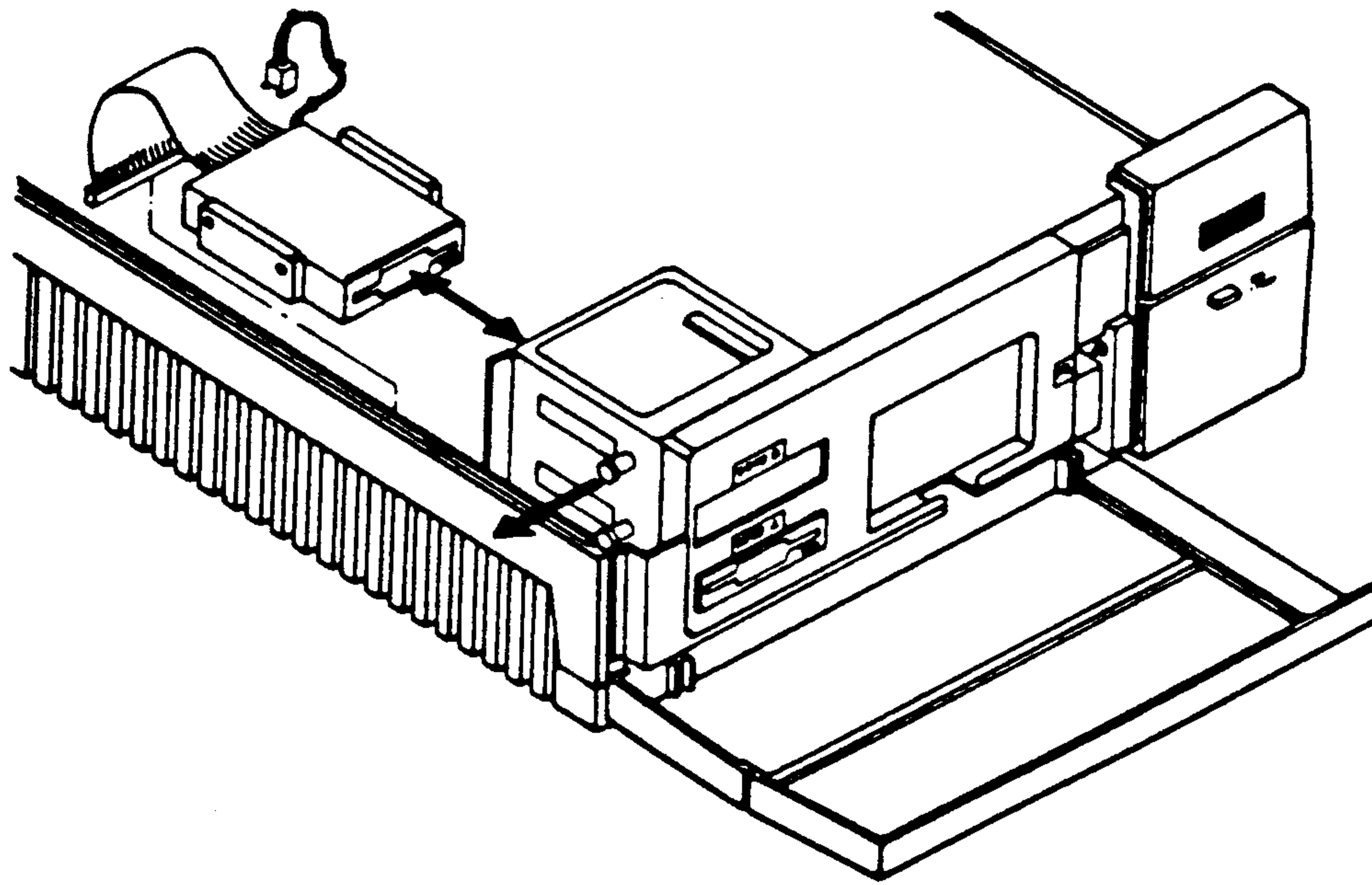

**Figure 4-16. Installing the Second Disk Drive**

**STEP 6:** Reconnect the power cord and IML the control unit.

After the power-on switch or IML button is pressed, the following events occur if the control unit is working correctly.

- The codes "P080" and then "P081" momentarily appear in the front panel indicators. These indicate the self-test process.
- The disk drive indicator lights up and the diskette loads software into 1374 memory.
- After about 25 to 30 seconds the disk access light goes out and the control unit is operational.

Any code remaining on the front panel indicators during testing or operation indicates a failure. Contact a service representative to correct the error condition.

---

### **ASYNCHRONOUS ADAPTER**

The Asynchronous Adapter provides the physical connection for ASCII devices and hosts and is used in connection with Asynchronous Communications Support (ACS) operational software. The Asynchronous Adapter consists of an Asynchronous Adapter PCB and a Connector Panel. The Connector Panel contains eight 25-pin D-Sub connectors. These connectors allow models 51R and 52R to support a total of eight A/A devices or hosts.

## 1374 USER-INSTALLABLE OPTIONS

The Asynchronous Adapter supports RS 232C and RS 422A interface on a port by port basis. Selection of the desired interface type is accomplished by setting a jumper (located on the inside of the connector panel) for each port. The factory default settings are for RS 232C operation, with jumpers for each port installed between posts one and two. To use a port with the RS 422A interface, move the jumper to posts two and three. The following list shows the corresponding jumpers and ports on the Connector Panel.

<u>Asynchronous Adapter Port</u>	<u>Jumper Label</u>
0	JP1
1	JP3
2	JP5
3	JP7
4	JP9
5	JP11
6	JP13
7	JP15

### CONFIGURATION

Configuring the control unit for the A/A ports supplied with this option is performed through the LCP (CO) facility.

### ASYNCHRONOUS ADAPTER PORT ADDRESSING

The connector module has eight ports labeled 0 - 7. A/A port addressing starts at port 16.

### INSTALLATION

To install the Asynchronous Adapter, perform the following steps:

- STEP 1:** Switch control unit power off and disconnect the power cord from the rear of the control unit.
- STEP 2:** Open the front door and loosen the two screws on the top edge of the control unit. Gently push the top cover back and lift to release it from the chassis.

## 1374 USER-INSTALLABLE OPTIONS

**STEP 3:** Remove the filler panels for the Connector Panel and the option slot. Install the Connector Panel into the Connector Panel opening and secure it with the two captive screws.

**STEP 4:** Insert and seat the Asynchronous Adapter PCB into the option slot, taking care to align it with the nylon guide at the front of the control unit and the opening in the rear of the chassis. Secure the PCB to the top edge of the chassis with the captive screw.

**STEP 5:** Connect the ribbon cables.

A/A PCB	to	Connector Panel
Ribbon cable P2		P1
Ribbon cable P3		P2
Ribbon cable P4		P3

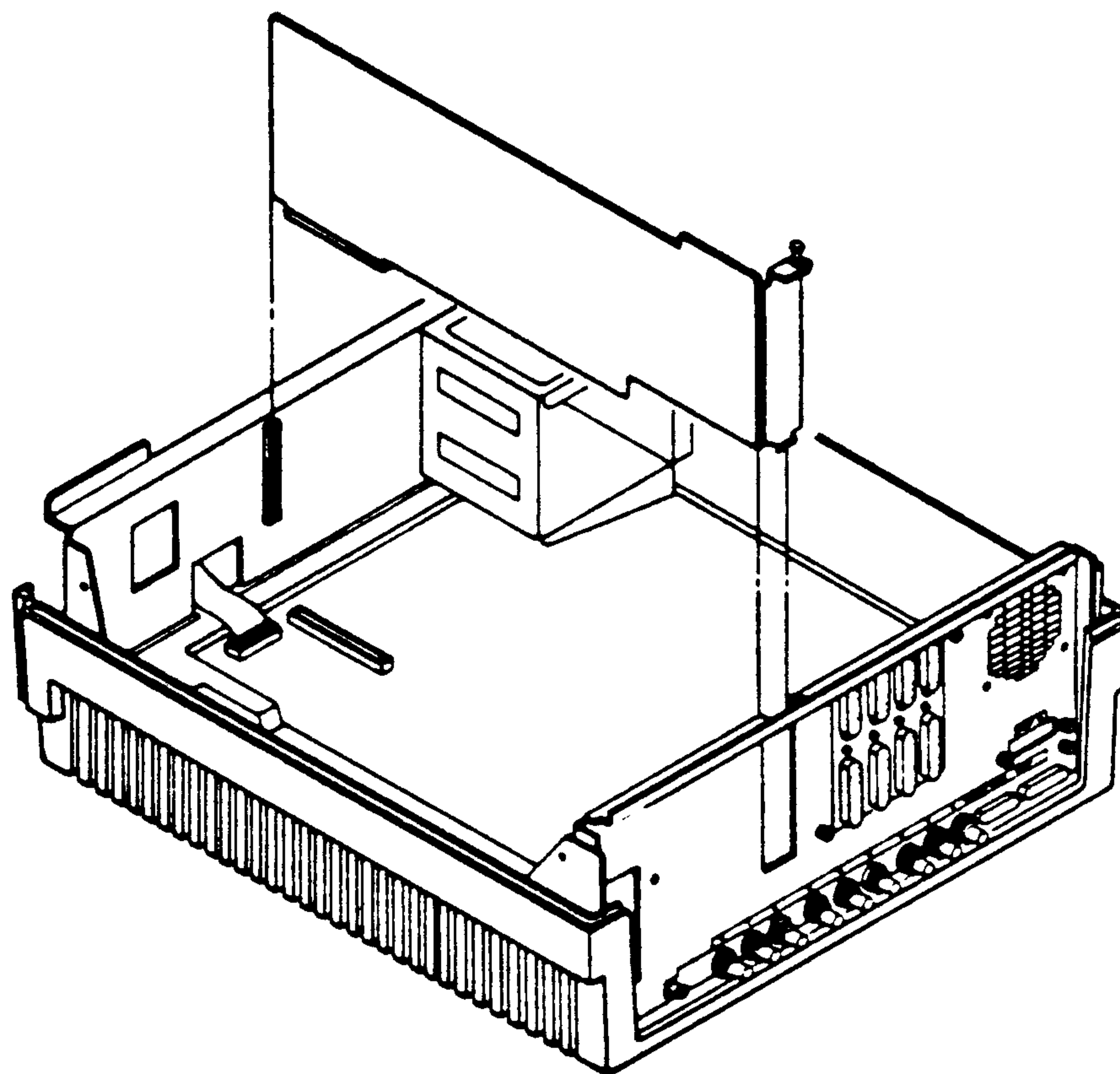

**Figure 4-17. Installing the Asynchronous Adapter**

**STEP 6:** Install the top cover and secure it with the two captive screws located on the top edge of the control panel.

**NOTE:** Before performing step 7, the ACS diskette and second disk drive must be installed in the control unit.

## **1374 USER-INSTALLABLE OPTIONS**

---

**STEP 7:** Reconnect the power cord and IML the control unit.

After the power-on switch or IML button is pressed, the following events occur if the control unit is working correctly.

- The codes "P080" and then "P081" momentarily appear in the front panel indicators. These indicate the self-test process.
- The disk drive indicator lights up and the diskette loads software into 1374 memory.
- After about 25 to 30 seconds the disk access light goes out and the control unit is operational.

Any code remaining on the front panel indicators during testing or operation indicates a failure. Contact a service representative to correct the error condition.

**STEP 8:** Attach the A/A device cables to the Asynchronous Adapter connector panel.

**STEP 9:** Configure the control unit for the required A/A devices.

### **1-MBYTE AND 512-KBYTE MEMORY EXPANSION MODULES**

The 1-MByte and 512-KByte Memory Expansion Modules provide 5XR series control units additional memory expansion of up to 2.5 MBytes. These control units have a standard 1.5-MByte memory.

The Memory Expansion Modules slide into vertical slots to the right of the disk drive housing.

### **INSTALLATION**

To install a Memory Expansion Module, perform the following steps:

**STEP 1:** Switch control unit power off and disconnect the power cord from the rear of the control unit.

**STEP 2:** Open the front door and loosen the two screws on the top edge of the control unit. Gently push the top cover back and lift to release it from the chassis.

**STEP 3:** Install the Memory Expansion Module into the board connector to the right of the disk drive housing. Install the retaining bracket fingers in the top edge of the disk drive housing and secure with the screw.

**STEP 4:** Install the top cover and secure it with the two captive screws located on the top edge of the control unit. Review installation instructions of other options you are installing before installing the top cover.

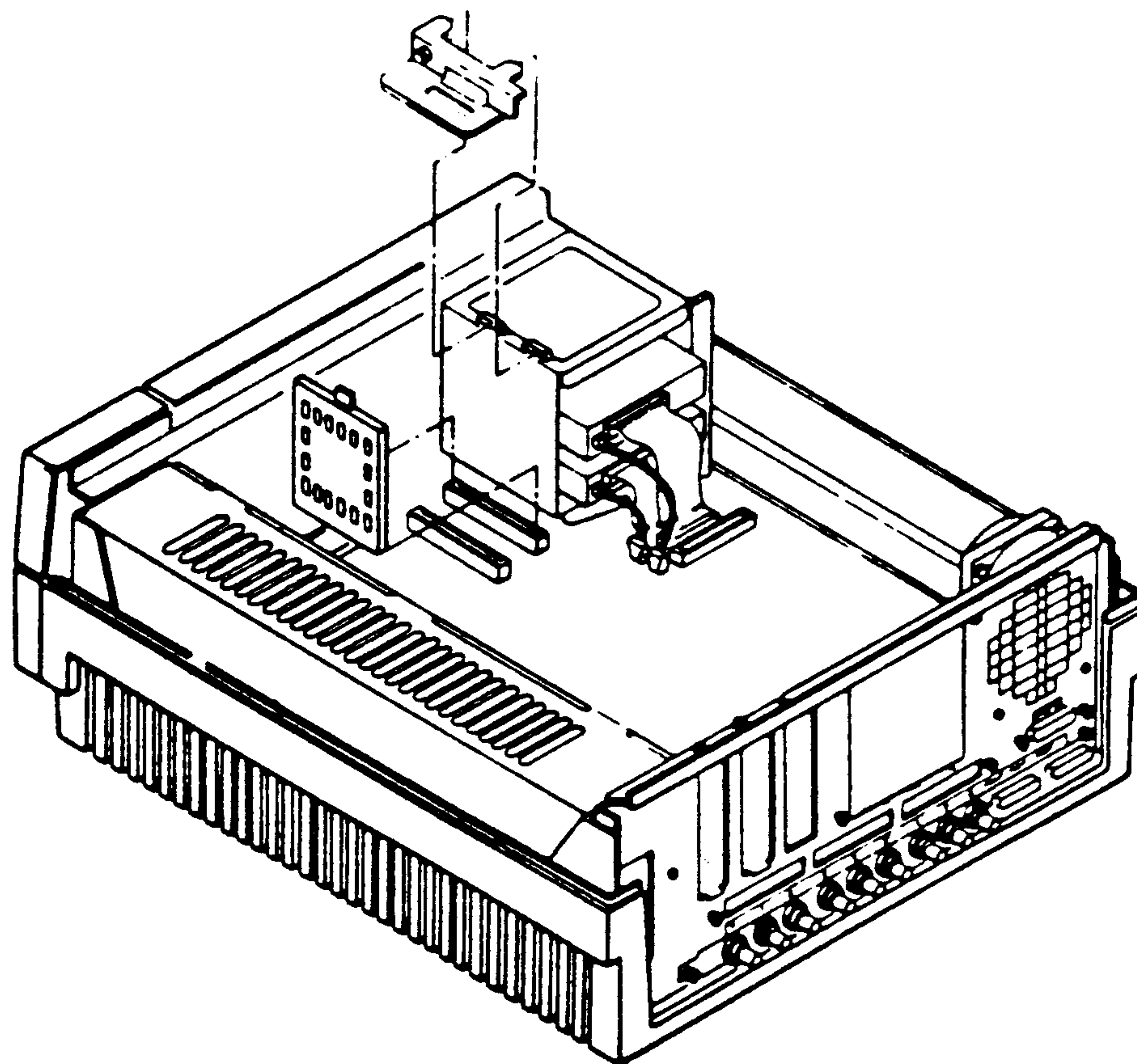

**Figure 4-18. Installing Memory Expansion Modules**

**STEP 5:** Reconnect the power cord and IML the system.

After the power-on switch or IML button is pressed, the following events occur if the control unit is working correctly.

- The codes "P080" and then "P081" momentarily appear in the front panel indicators. These indicate the self-test process.
- The disk drive indicator lights up and the diskette loads software into 1374 memory.
- After about 25 to 30 seconds the disk access light goes out and the control unit is operational.

Any code remaining on the front panel indicators during testing or operation indicates a failure. Contact a service representative to correct the error condition.

### TOKEN-RING GATEWAY

The Token-Ring Gateway provides the physical connection between model 51R and 52R control units and the Token-Ring LAN. If the Asynchronous Adapter is installed in the control unit, it must be removed before the Token-Ring Gateway can be installed.

## 1374 USER-INSTALLABLE OPTIONS

---

### CONFIGURATION

Configuring the control unit is performed via the LCP facility.

### INSTALLATION

To install the Token-Ring Gateway, perform the following steps:

- STEP 1:** Switch control unit power off and disconnect the power cord from the rear of the control unit.
- STEP 2:** Open the front door and loosen the two screws on the top edge of the control unit. Gently push the top cover back and lift it to release it from the chassis.
- STEP 3:** Locate and remove the blank filler panel for the option slot in the rear of the control unit (or remove the Asynchronous Adapter, if it is installed).
- STEP 4:** Insert and seat the Token-Ring Gateway PCB into the slot along the card guides and tighten the thumb screw.
- STEP 5:** Replace the top cover.
- STEP 6:** Reconnect the power cord and IML the control unit.

After the power-on switch or IML button is pressed, the following events occur if the control unit is working correctly.

- The codes "P080" and then "P081" momentarily appear in the front panel indicators. These indicate the self-test process.
- The disk drive indicator lights up and the diskette loads software into 1374 memory.
- After about 45 seconds the disk access light goes out and the control unit is operational.

Any code remaining in the front panel indicators during testing or operation indicates a failure. Contact a service representative to correct the error condition.

- STEP 7:** Attach the Token-Ring Gateway to the multistation access unit.
- STEP 8:** Configure the control unit for Token-Ring LAN support.

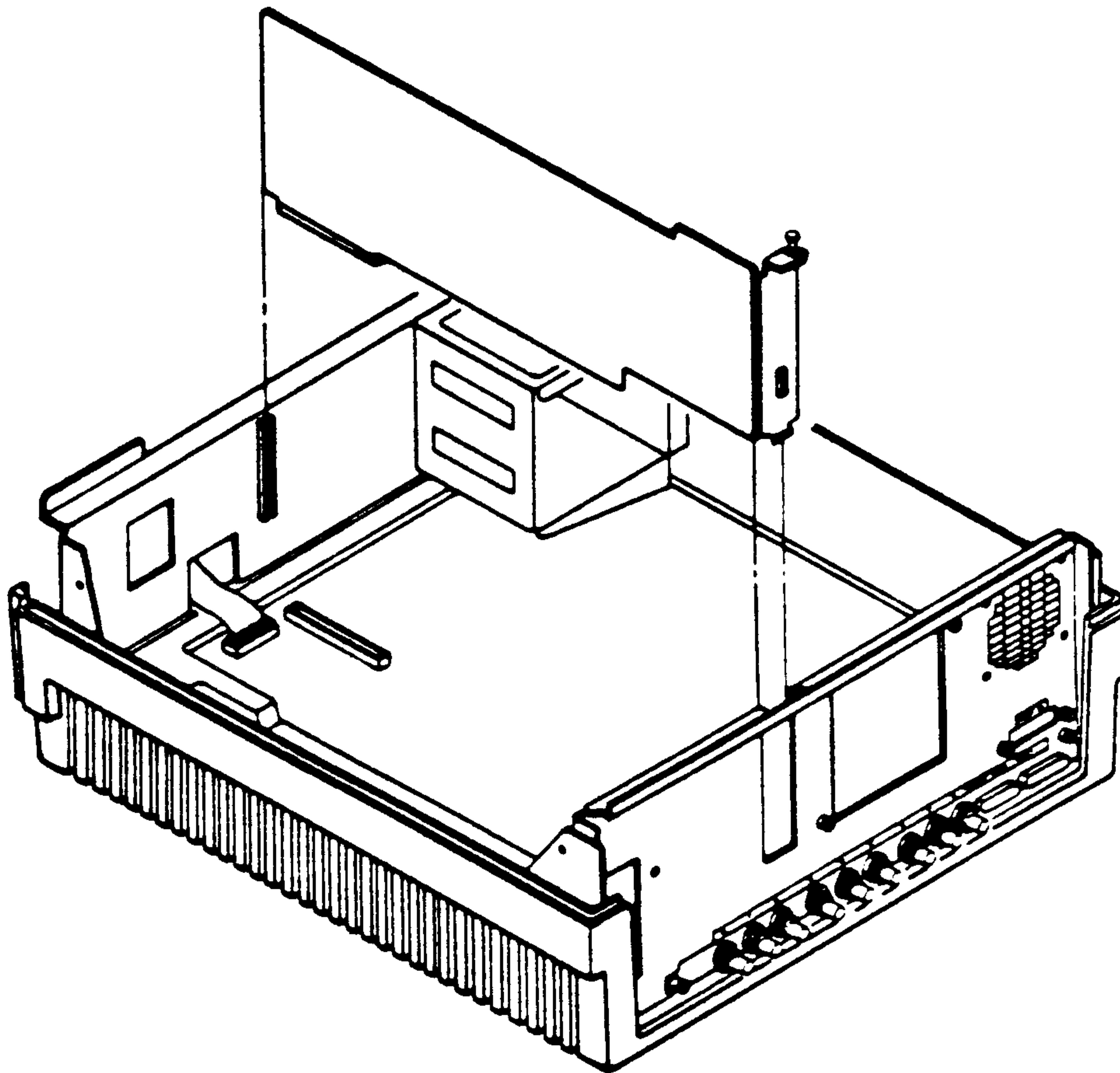

**Figure 4-19. Installing the Token-Ring Gateway**

### **FUNCTIONAL CONVERSIONS**

Model 51R and 52R control units can be converted to function as Model 53R Token-Ring downstream node control units by installing the Token-Ring Adapter PCB.

To convert a Model 51R or 52R control unit to a Model 53R, perform the following steps:

**STEP 1:** The Token-Ring Adapter is installed in the identical manner as the Token-Ring Gateway. Follow the instructions for installing the Token-Ring Gateway as outlined in the previous two pages.

**STEP 2:** Insert the Model 53R system diskette into the diskette drive.

**STEP 3:** Switch control unit power on. When the IML has completed, the control unit will function as the model to which it has been converted.

**NOTE:** Converting a model 51R or model 52R to a model 53R disables the remote host functions in the control unit when the IML is performed. To disable the Token Ring functions and return to remote host operation, re-IML the control unit with the appropriate remote diskette.

## 1374 USER-INSTALLABLE OPTIONS

---

### 1374 MODEL 61R

---

#### INTRODUCTION

In addition to the standard features provided by the 61R control unit, Memorex Telex offers optional PCBs that may be installed by the user.

These options are described in the following sections:

- **Dual-Host Option** – This section describes Dual SNA/IBM SDLC Host Support and installation of the Host Serial Interface Extender (HSIE).
- **Port Option PCBs** – This section introduces the Serial and Parallel Port Option PCBs and describes installation of these options. Asynchronous Communications Support (ACS) is required to use the Serial or Parallel Port options. Configuration and operation of ACS is described in the 1374 ACS Operations Manual.
- **512-KByte Memory Expansion PCB** – This section explains how to install the Memory Expansion PCB.

#### DUAL-HOST OPTION

##### DUAL IBM SNA/SDLC HOST OPTION

The Dual IBM SNA/SDLC Host option provides concurrent support for two IBM SNA/SDLC host links on model 61R control units. This option requires a second full-function serial interface. The additional serial interface is provided by installing a type 1 or 2 Host Serial Interface Extender, type 1 or 2, (HSIE1 for RS 232C/V.35 or HSIE2 for X.21). Operational software for this option is contained on the appropriate system diskette.

##### HOST SERIAL INTERFACE EXTENDER

The Host Serial Interface Extender (labeled "Host 2") is a full Extender function RS 232C serial interface that supports a modem connected between the control unit and the link to the second remote IBM host.

The HSIE can be installed in option slot 2 or 3 of the control unit. The external connector for the second host is provided through a 25-pin D-sub connector that supports RS 232C signals. Refer to the *1374 ACS Operations Manual* for information on cable specifications and signal pin assignments.

### INSTALLING THE HOST SERIAL INTERFACE EXTENDER

Installing the HSIE requires that the 1374 control unit be off line for approximately 15 minutes.

**NOTE:** In LCP, option slot 2 displays as port 10 and option slot 3 displays as port 9, regardless of the option PCBs you install in option slots 2 and 3. Use the LCP Configure Host command to configure the second host link.

### REQUIRED TOOLS

Installation of the Host Serial Expansion PCB requires a medium-size, flat-blade screwdriver.

### INSTALLATION

To install the PCB, perform the following steps:

- STEP 1:** Switch control unit power off and disconnect the power cord from the rear of the unit.
- STEP 2:** Open the access door on the top of the control unit, and locate an empty option slot (either slot 2 or 3).
- STEP 3:** Locate and remove the filler panel for the desired option slot in the rear of the control unit.
- STEP 4:** Grasp the PCB by the top and carefully guide it into the proper slot connector.
- STEP 5:** Ensure that the fingers on the PCB are aligned with the connector. Push the PCB firmly into the connector.
- STEP 6:** Install the retaining screw securing the PCB to the cutout panel on the rear of the control unit and attach the loopback test connector.
- STEP 7:** Close the access door and reconnect the power cord.
- STEP 8:** Switch control unit power on and run one complete pass of the diagnostic tests. (Refer to the *1374 Troubleshooting Guide* for information about the diagnostic tests.)
- STEP 9:** Remove the loopback test connector (if installed) and perform the appropriate configuration procedure for the second IBM remote host. Refer to the "Configure Host" chapter in the *1374 Configuration Guide*.

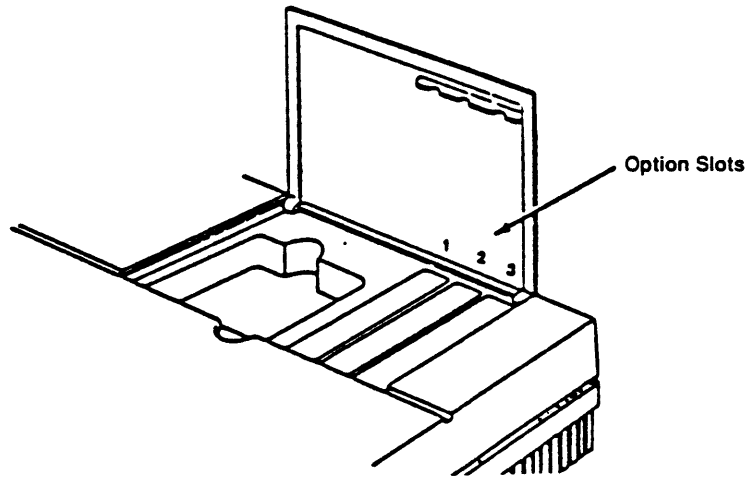

Figure 4-20. Option Slot Numbering

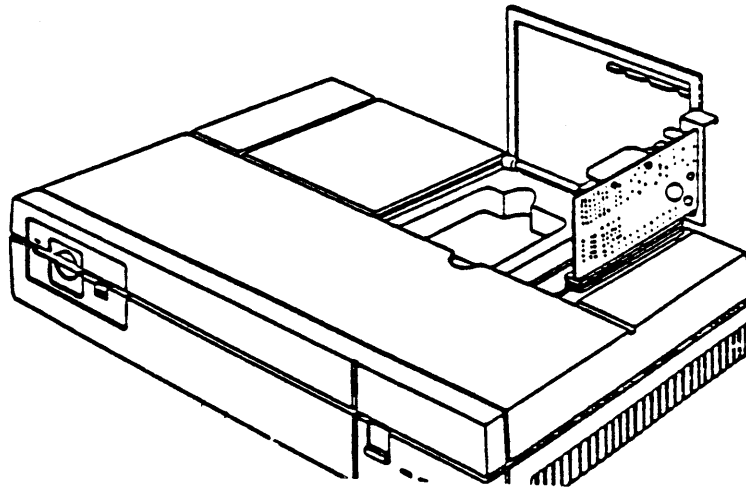

Figure 4-21. Host Serial Expansion PCB Installation (Slot 2 or 3)

### SERIAL PORT OPTION PCB

The Serial Port Option PCB is a full-function serial interface that supports ASCII codes and asynchronous protocol communications between the control unit and an Asynchronous/ASCII (A/A) device or host. The Serial Port Option PCB is required for ACS operation. Special hardware and software modules in 61R control units perform the required conversions between the ASCII data format and the 3270 mode data stream sent to and from the host processor. The maximum individual line speed is 9600 bps.

The Serial Port Option PCB can be installed in option slot 2 or 3 of the control unit. The external connector for the A/A device (host, terminal, or printer) is provided through a 9-pin female D-sub connector that supports RS 232C signals.

## 1374 USER-INSTALLABLE OPTIONS

---

ACS operational software for the Serial Port option is shipped on a separate diskette and must be copied onto the appropriate system diskette prior to ACS operation.

Refer to the *1374 ACS Operations Manual* for information on cable specifications and signal pin assignments.

### **PARALLEL PORT OPTION PCB**

The Parallel Port Option PCB can be installed in option slot 2 or 3 of the control unit. This option supports parallel interfaced printers using a Centronics electrical interface. Printers attached to this option appear to the host as an IBM 3287 Model 1 printer.

ACS operational software for the Parallel Port option is shipped on a separate diskette and must be copied onto the appropriate system diskette prior to ACS operation.

### **INSTALLING THE PORT OPTION PCB**

Installing the Port Option PCB requires the 1374 control unit to be off line for approximately 15 minutes. The following installation procedure applies to all Port Option PCBs.

**NOTE:** In LCP, option slot 2 displays as port 9 and option slot 3 displays as port 8, regardless of the option PCBs you install in option slots 2 and 3.

### **REQUIRED TOOLS**

Installation of the option PCBs requires a medium-size, flat-blade screwdriver.

### **INSTALLATION**

To install a Port Option PCB, perform the following steps:

- STEP 1:** Switch control unit power off and disconnect the power cord from the rear of the unit.
- STEP 2:** Open the access door on the top of the control unit, and locate an empty option slot (either slot 2 or 3).
- STEP 3:** Locate and remove the filler panel for the desired option slot in the rear of the control unit.
- STEP 4:** Grasp the PCB by the top and carefully guide it into the proper slot connector.
- STEP 5:** Ensure that the fingers on the PCB are aligned with the connector. Push the PCB firmly into the connector.

## 1374 USER-INSTALLABLE OPTIONS

---

- STEP 6:** Install the retaining screw securing the PCB to the cutout panel on the rear of the control unit and attach the loopback test connector.
- STEP 7:** Close the access door and reconnect the power cord.
- STEP 8:** Switch control unit power on and run one complete pass of the diagnostic tests. (Refer to the *1374 Troubleshooting Guide* for information about the diagnostic tests.)
- STEP 9:** Remove the loopback test connector (if installed) and perform the appropriate configuration procedure for the Port Option PCB. If predefined device configurations are being used, refer to the "Configure Options" chapter in the *1374 Configuration Guide*. To modify predefined device configurations, or to configure other devices, refer to the "ASCII Definition Utility (ADU)" chapter in the *1374 Offline Utility Operations Manual*.

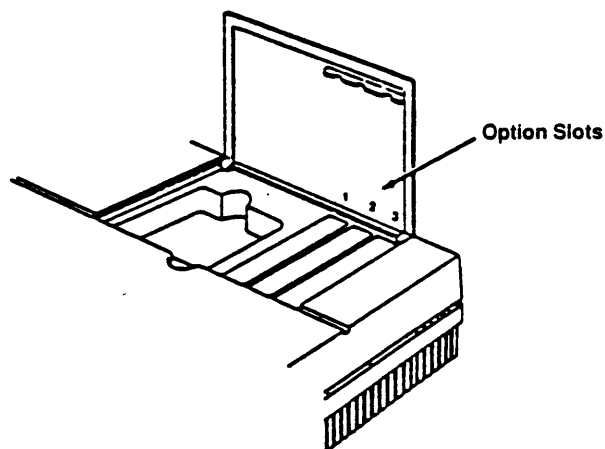

Figure 4-22. Option Slot Numbering

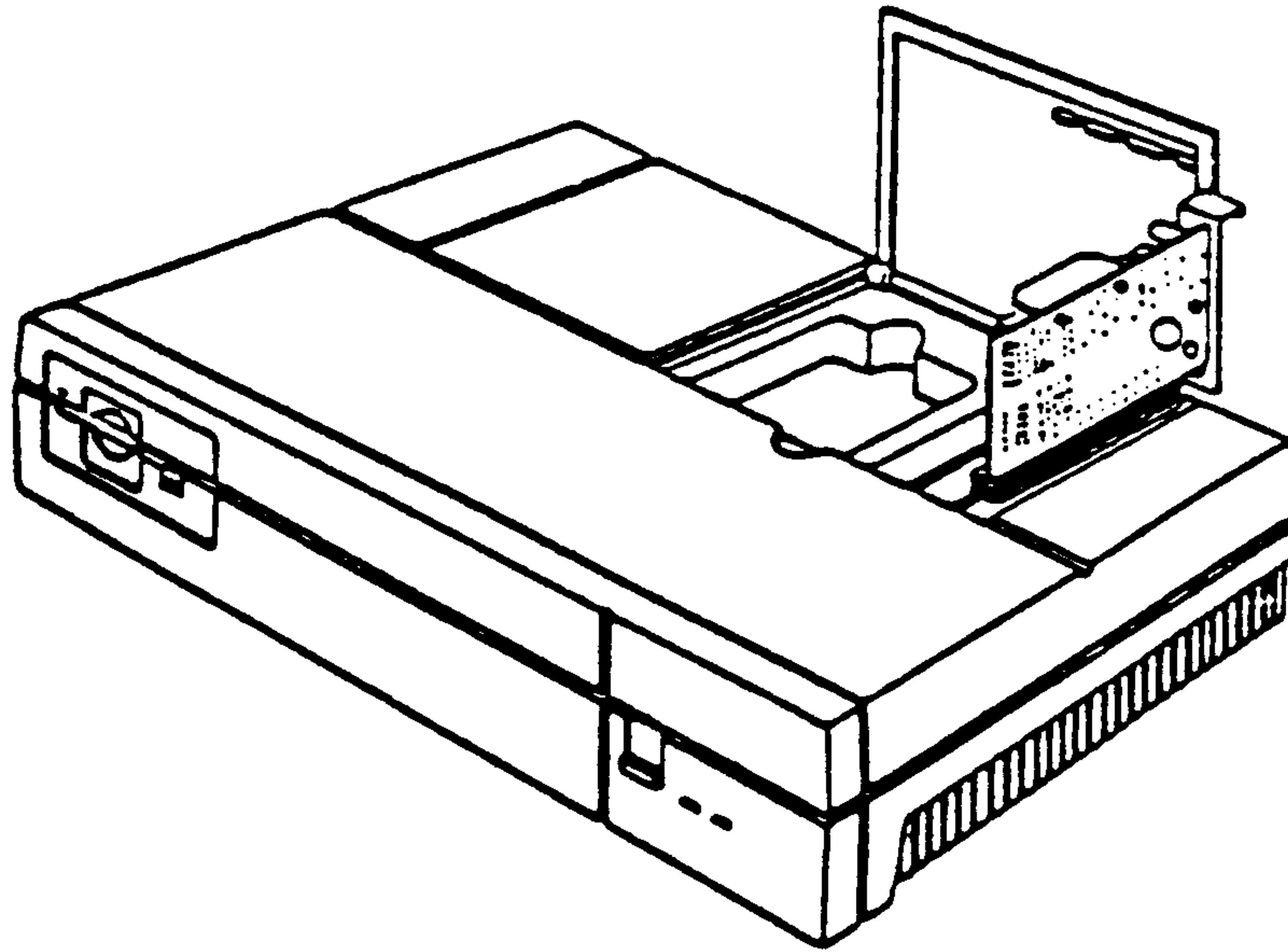

Figure 4-23. Port Option PCB Installation (Slot 2 or 3)

### CONFIGURING THE PORT OPTION PCB

The LCP Configure Options (CO) command is used to define ASCII device parameters to the control unit. Refer to the *1374 ACS Operations Manual* for information on configuring the Port Option PCBs for Asynchronous/ASCII device support.

### INSTALLING THE MEMORY EXPANSION PCB

Each Memory Expansion PCB contains 512 KBytes of memory. Installing the Memory Expansion PCB requires the 1374 control unit to be off line for approximately 15 minutes.

### REQUIRED TOOLS

Installation of the Memory Expansion PCB requires a medium-size, flat-blade screwdriver.

### INSTALLATION

To install the Memory Expansion PCB, perform the following steps:

- STEP 1:** Switch control unit power off and disconnect the power cord from the rear of the unit.
- STEP 2:** Open the access door on the top of the control unit, and locate option slot 1. The Memory Expansion PCB must be installed in option slot 1.
- STEP 3:** Locate the filler panel in the rear of the control unit for option slot 1.

## 1374 USER-INSTALLABLE OPTIONS

---

- STEP 4:** Remove the filler panel by turning the retaining screw counterclockwise.
- STEP 5:** Grasp the PCB by the top and carefully guide it into the proper slot connector.
- STEP 6:** Ensure that the fingers on the PCB are aligned with the connector. Push the PCB firmly into the connector.
- STEP 7:** Install the retaining screw securing the PCB to the cutout panel on the rear of the control unit and attach the loopback test connector.
- STEP 8:** Close the access door and reconnect the power cord.
- STEP 9:** Switch control unit power on and run one complete pass of the diagnostic tests. (Refer to the *1374 Troubleshooting Guide* for information about the diagnostic tests.)

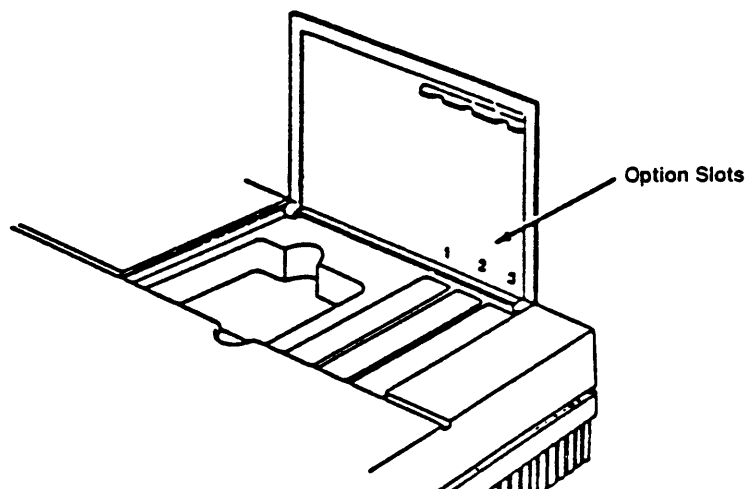

Figure 4-24. Option Slot Numbering

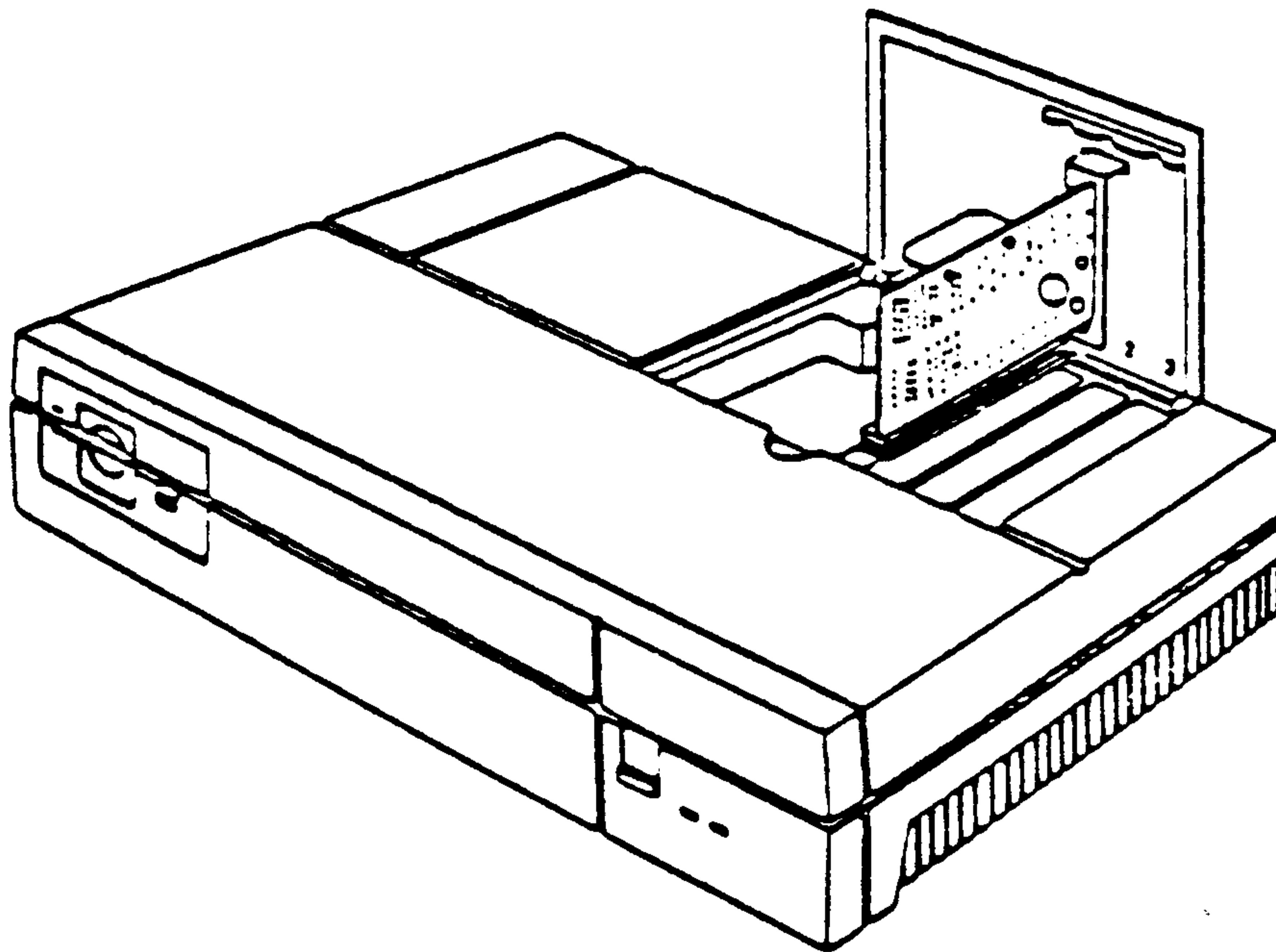

Figure 4-25. Memory Expansion PCB Installation

---

## 1374 MODEL 71R/72R/73R

---

### INTRODUCTION

In addition to the standard features provided by 7XR series control units, Memorex Telex offers several PCBs that may be installed by the user.

These options are described in the following sections:

- **Port Option PCBs** – This section introduces the Serial and Parallel Port Option PCBs and describes installation of these options. Asynchronous Communications Support (ACS) is required to use the Serial or Parallel Port options. Configuration and operation of ACS is described in the *1374 ACS Operations Manual*.
- **4-Port Coax Extender Adapter** – This section introduces the 4-port Coax Extender Adapter and describes how to install it in the 7XR control units.
- **512-KByte Memory Expansion PCB** – This section explains how to install the Memory Expansion PCB in 71R model 2 and 72R model 2 control units.

## **1374 USER-INSTALLABLE OPTIONS**

---

### **SERIAL PORT OPTION PCB**

The Serial Port Option PCB is a full-function serial interface that supports ASCII codes and asynchronous protocol communications between the control unit and an Asynchronous/ASCII (A/A) device or host. The Serial Port Option PCB is required for ACS operation. Special hardware and software modules in the 7XR series control units perform the required conversions between the ASCII data format and the 3270 mode data stream sent to and from the host processor. The maximum individual line speed is 9600 bps.

The Serial Port Option PCB can be installed in option slot 2 or 3 of the control unit. The external connector for the A/A device (host, terminal, or printer) is provided through a 9-pin female D-sub connector that supports RS 232C signals.

ACS operational software for the Serial Port option is shipped on a separate diskette and must be copied onto the appropriate system diskette prior to ACS operation.

Refer to the *1374 ACS Operations Manual* for information on cable specifications and signal pin assignments.

### **PARALLEL PORT OPTION PCB**

The Parallel Port Option PCB can be installed in option slot 2 or 3 of the control unit. This option supports parallel interfaced printers using a Centronics electrical interface. Printers attached to this option appear to the host as an IBM 3287 model 1 printer.

ACS operational software for the Parallel Port option is shipped on a separate diskette and must be copied onto the appropriate system diskette prior to ACS operation.

### **INSTALLING THE PORT OPTION PCB**

Installing the Port Option PCB requires the 1374 control unit to be off line for approximately 15 minutes. The following installation procedure applies to all Port Option PCBs.

**NOTE:** In LCP, option slot 2 displays as port 9 and option slot 3 displays as port 8, regardless of the option PCBs you install in option slots 2 and 3.

#### **REQUIRED TOOLS**

Installation of the option PCBs requires a medium-size, flat-blade screwdriver.

### INSTALLATION

To install a Port Option PCB, perform the following steps:

- STEP 1:** Switch control unit power off and disconnect the power cord from the rear of the unit.
- STEP 2:** Open the access door on the top of the control unit, and locate an empty option slot (either slot 2 or 3).
- STEP 3:** Locate and remove the filler panel for the desired option slot in the rear of the control unit.
- STEP 4:** Grasp the PCB by the top and carefully guide it into the proper slot connector.
- STEP 5:** Ensure that the fingers on the PCB are aligned with the connector. Push the PCB firmly into the connector.
- STEP 6:** Install the retaining screw securing the PCB to the cutout panel on the rear of the control unit and attach the loopback test connector.
- STEP 7:** Close the access door and reconnect the power cord.
- STEP 8:** Switch control unit power on and run one complete pass of the diagnostic tests. (Refer to the *1374 Troubleshooting Guide* for information about the diagnostic tests.)
- STEP 9:** Remove the loopback test connector (if installed) and perform the appropriate configuration procedure for the Port Option PCB. If predefined device configurations are being used, refer to the "Configure Options" chapter in the *1374 Configuration Guide*. To modify predefined device configurations, or to configure other devices, refer to the "ASCII Definition Utility (ADU)" chapter in the *1374 Offline Utility Operations Manual*.

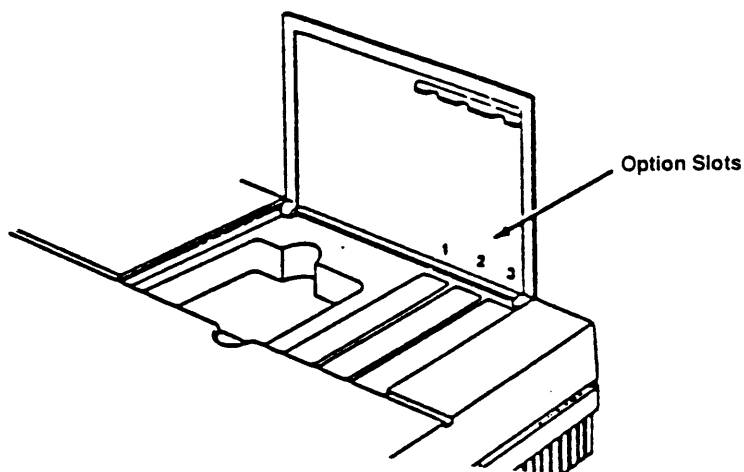

Figure 4-26. Option Slot Numbering

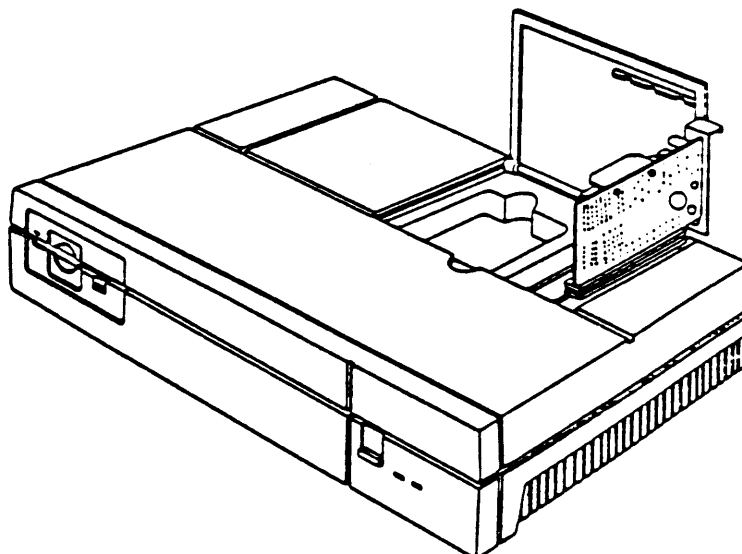

Figure 4-27. Port Option PCB Installation (Slot 2 or 3)

### CONFIGURING THE PORT OPTION PCB

The LCP Configure Options (CO) command is used to define ASCII device parameters to the 7XR control units. Refer to the *1374 ACS Operations Manual* for information on configuring the Port Option PCBs for Asynchronous/ASCII device support.

### 4-PORT COAX EXTENDER ADAPTER

Installing the 4-Port Coax Extender Adapter (CEA) doubles the coax port capacity of 7XR series control units, upgrading the coax port capacity from four to eight.

## 1374 USER-INSTALLABLE OPTIONS

The CEA PCB resides alongside the standard 4-port assembly and consists of the coax interface circuitry and connectors for four additional coax ports.

### CONFIGURATION

Configuration for the additional coax ports supplied with this option is performed through the LCP facility.

### INSTALLATION

To install the Coax Extender Adapter, perform the following steps:

- STEP 1:** Switch control unit power off and disconnect the power cord from the rear of the control unit.
- STEP 2:** Looking at the rear of the control unit, locate the filler panel for the CEA PCB on the right side of the unit.
- STEP 3:** Remove the thumbscrew that secures the filler panel to the rear of the control unit.
- STEP 4:** Insert and seat the CEA PCB into the slot on the bottom rear of the unit.
- STEP 5:** Insert and tighten the thumbscrew.
- STEP 6:** Reconnect the power cord.
- STEP 7:** Install the diagnostic diskette.
- STEP 8:** Switch control unit power on and run one complete pass of the diagnostic tests.
- STEP 9:** Configure the control unit for the additional coax devices.

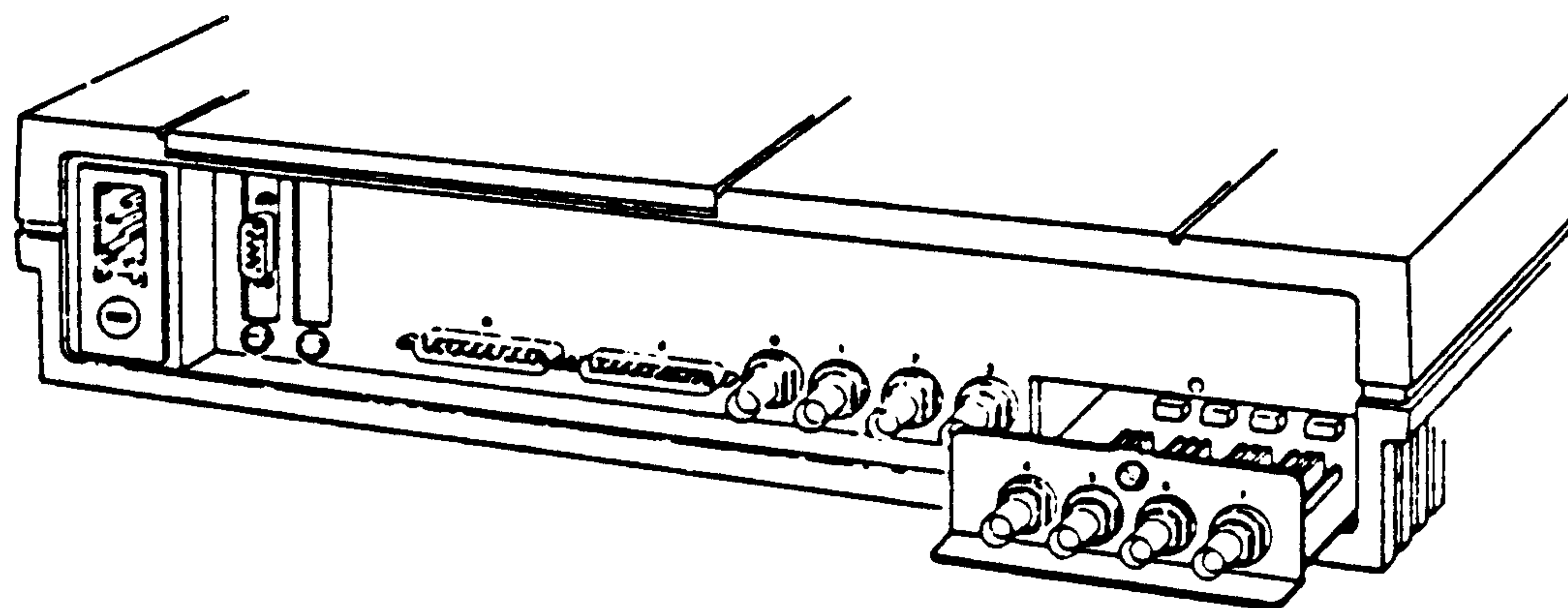

Figure 4-28. 4-Port Coax Extender Adapter Installation

## **1374 USER-INSTALLABLE OPTIONS**

---

### **INSTALLING THE MEMORY EXPANSION PCB**

Installing the Memory Expansion PCB requires the 1374 control unit to be off line for approximately 15 minutes. The Memory Expansion PCB is optional on 71R and 72R model 2 control units only. The Memory Expansion PCB is standard for all 7XR model 1 and 73R model 2 control units.

### **REQUIRED TOOLS**

Installation of the Memory Expansion PCB requires a medium-size, flat-blade screwdriver.

### **INSTALLATION**

To install the Memory Expansion PCB, perform the following steps:

- STEP 1:** Switch control unit power off and disconnect the power cord from the rear of the unit.
- STEP 2:** Open the access door on the top of the control unit, and locate option slot 1. The Memory Expansion PCB must be installed in option slot 1.
- STEP 3:** Locate the filler panel in the rear of the control unit for option slot 1.
- STEP 4:** Remove the filler panel by turning the retaining screw counterclockwise.
- STEP 5:** Grasp the PCB by the top and carefully guide it into the proper slot connector.
- STEP 6:** Ensure that the fingers on the PCB are aligned with the connector. Push the PCB firmly into the connector.
- STEP 7:** Install the retaining screw securing the PCB to the cutout panel on the rear of the control unit and attach the loopback test connector.
- STEP 8:** Close the access door and reconnect the power cord.
- STEP 9:** Switch control unit power on and run one complete pass of the diagnostic tests. (Refer to the *1374 Troubleshooting Guide* for information about the diagnostic tests.)

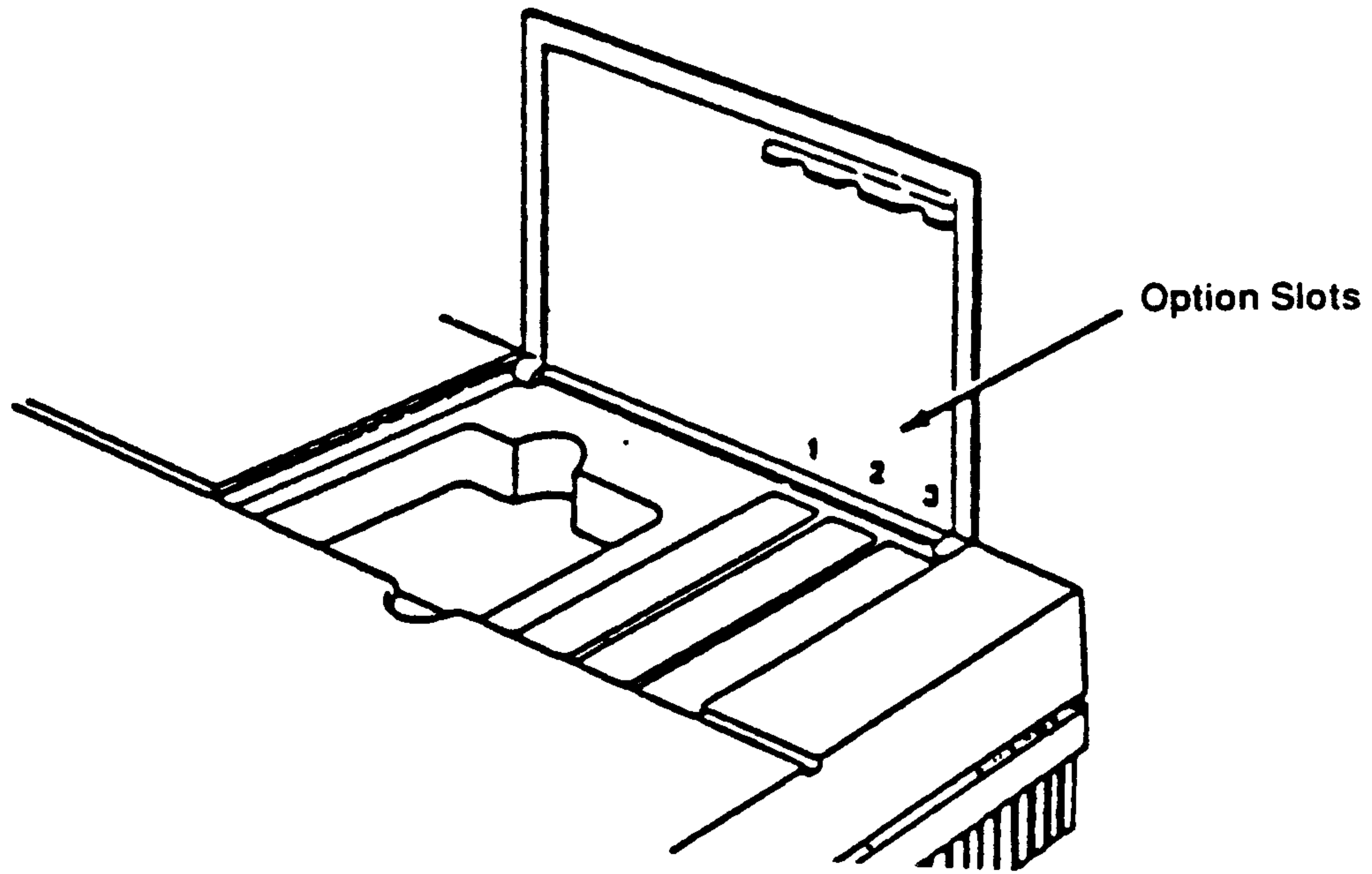

Figure 4-29. Option Slot Numbering

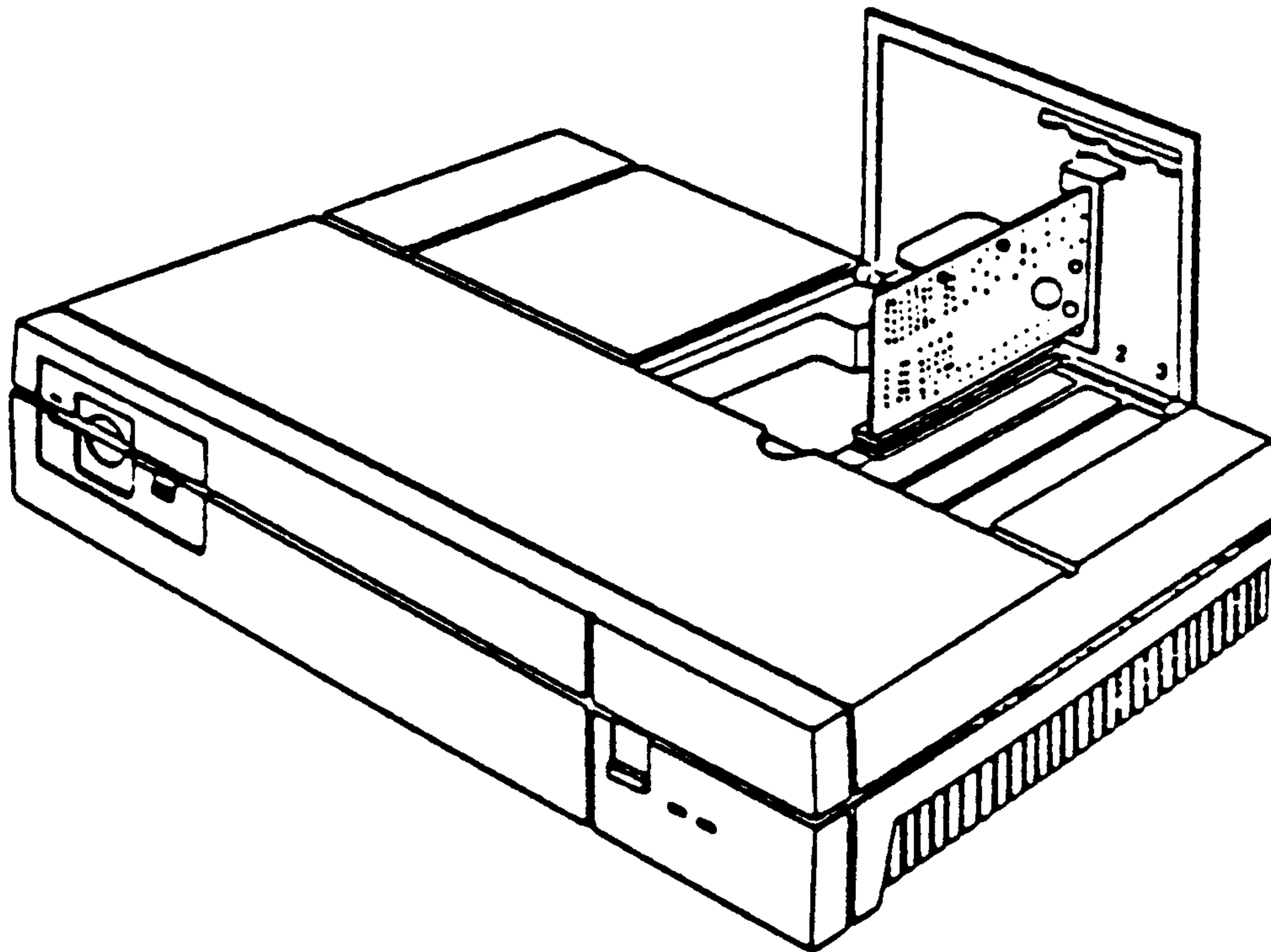

Figure 4-30. Memory Expansion PCB Installation

