

Chapter 2

Host Communication

HOST COMMUNICATION

HOST INTERFACES

The 1374 control unit family offers an array of interfaces for connecting to a remote or local host. In addition to the variety of electrical interfaces supported, SNA/SDLC, BSC, and SNA/X.25 protocols are supported at various link speeds. The next table shows single- and dual-host options for the 1374 control units.

Model	Hardware Interface		Software		Link Speed	
	Host 1	Host 2	Host 1	Host 2	Host 1	Host 2
1L	Channel	-	SNA	-	1.25-MB	-
	Channel	-	BSC	-	1.25-MB	-
	Channel	RS 232/V.35	SNA	SNA/SDLC	1.25-MB	19.2-KB
1R/41R	RS 232/V.35	-	SNA/SDLC	-	64.0-KB	-
	RS 232/V.35	-	SNA/X.25	-	19.2-KB	-
	RS 232/V.35	-	BSC	-	19.2-KB	-
	RS 232/V.35	RS 232/V.35	SNA/SDLC	SNA/SDLC	19.2-KB	19.2-KB
	RS 232/V.35	RS 232/V.35	SNA/SDLC	BSC	19.2-KB	9.6-KB
	RS 232/V.35	X.21	SNA/SDLC	SNA/SDLC	19.2-KB	19.2-KB
2R/42R	X.21	-	SNA/SDLC	-	64.0-KB	-
	X.21	-	SNA/X.25	-	19.2-KB	-
	X.21	X.21	SNA/SDLC	SNA/SDLC	19.2-KB	19.2-KB
	X.21	RS 232/V.35	SNA/SDLC	SNA/SDLC	19.2-KB	19.2-KB
	X.21	RS 232/V.35	SNA/SDLC	BSC	19.2-KB	9.6-KB
51R	RS 232/V.35	-	SNA/SDLC	-	64.0-KB	-
	RS 232/V.35	-	SNA/X.25	-	19.2-KB	-
	RS 232/V.35	-	BSC	-	9.6-KB	-
	RS 232/V.35	RS 232/V.35	SNA/SDLC	SNA/SDLC	9.6-KB	9.6-KB
	RS 232/V.35	X.21	SNA/SDLC	SNA/SDLC	9.6-KB	9.6-KB
52R	X.21	-	SNA/SDLC	-	64.0-KB	-
	X.21	-	SNA/X.25	-	19.2-KB	-
	X.21	X.21	SNA/SDLC	SNA/SDLC	9.6-KB	9.6-KB
	X.21	RS 232/V.35	SNA/SDLC	SNA/SDLC	9.6-KB	9.6-KB
61R	RS 232/V.35	-	SNA/SDLC	-	64.0-KB	-
	RS 232/V.35	-	SNA/X.25	-	19.2-KB	-
	RS 232/V.35	-	BSC	-	9.6-KB	-
	RS 232/V.35	RS 232	SNA/SDLC	SNA/SDLC	9.6-KB	9.6-KB

Table 2-1. 1374 Control Unit Interfacing

HOST COMMUNICATION

Model	Hardware Interface		Software		Link Speed	
	Host 1	Host 2	Host 1	Host 2	Host 1	Host 2
71R	RS 232/V.35	-	SNA/SDLC	-	64.0-KB	-
	RS 232/V.35	-	SNA/X.25	-	19.2-KB	-
	RS 232/V.35	-	BSC	-	9.6-KB	-
72R	X.21	-	SNA/SDLC	-	64.0-KB	-
	X.21	-	SNA/X.25	-	19.2-KB	-

Table 2-1. 1374 Control Unit Interfacing (Continued)

LOCAL COMMUNICATIONS OVERVIEW

CHANNEL ATTACHMENT

Model 1L supports SNA or non-SNA (3272-extended) operation. The unit may be attached to selector, byte multiplexer, or block multiplexer channels of IBM or compatible processors.

Operation is byte mode or burst mode at data rates of up to 1.25 MByte/second. Because of host system performance considerations, operation on selector channels or non-DCC (Disconnect Command Chaining) subchannels is not recommended.

BUS AND TAG CABLE REQUIREMENTS

Model 1L attaches to a host processor with IBM-type bus and tag cables. The control unit may be attached directly to the channel or to another control unit.

If new channel cables are required, the specific channel configuration and the distance between the model 1L and the host channel or next control unit must be considered. Standard 20-foot lengths are available; custom lengths may be requested.

The host cables are prepared by the customer as described in the Setup Instructions. The service representative will complete the bus and tag cable installation.

PRIORITY

Model 1L is a fully data-buffered device and is not subject to data overruns. The control unit may be assigned a lower priority on the channel than other devices subject to data overrun. Determine the priority setting of the control unit and inform the service representative prior to installation.

TERMINATORS

If the model 1L control unit is the last control unit on the channel, channel terminators must be moved to the control unit. No additional terminators are required.

REMOTE COMMUNICATIONS OVERVIEW

COMMUNICATIONS INTERFACE

Models 1R, 2R, 41R, 42R, 51R, 52R, and 61R units support two dedicated ports for remote host communications. Models 1R, 41R, 51R, 61R, and 71R control units support RS 232C, V.35, and X.21bis signals (V.28 and V.35 configurations) for the host ports. Models 2R, 42R, 52R, and 72R control units support X.21 using the X.27 (RS 422A) electrical configuration. Models 3R, 43R, 53R, and 73R control units support the IEEE 802.5 token ring interface. The signal definitions and connector pinouts are shown in the following tables and figures.

Pin #	Sig Name	<-DIR-> DTE-DCE	Function
1	NC		No Connection
2	T(A)	-->	Transmit A – Data signals sent from the controller to the modem.
3	C(A)	-->	Control A – Control signals from the controller to the modem
4	R(A)	<--	Receive A – Data signals received by the modem and sent to the controller.
5	I(A)	<--	Indication A – Signal from the modem to indicate the condition state of the call control process to the controller.
6	S(A)	<--	Signal Timing A – Generated by the modem to provide timing to the controller.

The X.21 interface implements the X.27 standard using a 15-pin male DSub connector for the Host 1, Type 2 connection. The X.27 electrical interface requires differential drivers and receivers for the X.21 signals. Differential drivers use paired signals (A and B) for transfer of data. As an example, T(A) and T(B) combine to form the transmitted data.

Table 2-2. X.21 Communication Signal Definitions

HOST COMMUNICATION

Pin #	Sig Name	<-DIR-> DTE-DCE	Function
7	NC		No Connection
8	G	<-->	Signal Ground – Ground reference for signals. Tied to Frame Ground in the control unit.
9	T(B)	-->	Transmit B – Data signals sent from the controller to the modem.
10	C(B)	-->	Control B – Control signals from the controller to the modem.
11	R(B)	<--	Receive B – Data signals received by the modem and sent to the controller.
12	I(B)	<--	Indication B – Signal from the modem to indicate the condition state of the call control process to the controller.
13	S(B)	-->	Signal Timing B – Generated by the modem to provide timing to the controller.
14	NC		No Connection
15	Reserved		Reserved for Future Use

The X.21 interface implements the X.27 standard using a 15-pin male DSub connector for the Host 1, Type 2 connection. The X.27 electrical interface requires differential drivers and receivers for the X.21 signals. Differential drivers use paired signals (A and B) for transfer of data. As an example, T(A) and T(B) combine to form the transmitted data.

Table 2-2. X.21 Communication Signal Definitions (Continued)

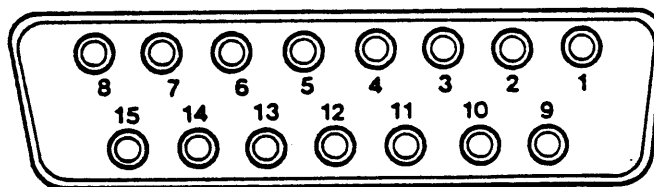

Figure 2-1. X.21 Connector Pin Numbering

HOST COMMUNICATION

Pin #	Sig Name	EIA Cir	CCIT Equiv	<-DIR-> DTE-DCE	Function
1	FG	AA	101	<-->	Frame Ground – Connects unit chassis together.
2	TxD*	BA	103	-->	Transmitted Data – Data signals sent from the controller to the modem.
3	RxD*	BB	104	<--	Received Data – Data signals received by the modem and sent to the controller.
4	RTS*	CA	106	-->	Request to Send – Conditions the modem for data transmission and, on a half-duplex line controls the direction of data transmission of the modem.
5	CTS	CB	106	<--	Clear to Send – Generated by the modem to indicate whether the data set is ready to transmit data in response to RTS from the control unit.
6	DSR	CC	107	<--	Data Set Ready – Indicates ready status of the modem in response to the line status.
7	SG*	AB	102	<-->	Signal Ground – Ground reference for signals. Tied to Frame Ground in the control unit.
8	DCD	CF	109		Data Carrier Detect – Data carrier received line signal detector.
11	STDBY**			-->	Standby – IBM modem test signal. Not supported by the control unit; pin is always low.
15	TRxC	DB	114	<--	Transmitter Clock – Provides timing information to the controller to allow it to synchronize the transmitted data (TxD) with the modem.

Signals not listed on this chart are not supported by the control unit.

* Maintenance port signals. These signals are the only signals supported by the maintenance port. RTS and DTR are always maintained at a high level. CTS and all other signals are ignored.

** IBM modem signals only (for test purposes). For IBM implementation, pins 14 and 7 are connected for V.35.

Table 2-3. RS 232C Communication Signal Definitions

HOST COMMUNICATION

Pin #	Sig Name	EIA Cir	CCIT Equiv	<-DIR-> DTE-DCE	Function
17	RTxC	DD	115	<--	Receiver Clock – Provides the controller with received timing information to synchronize the received (RxD) data with the controller.
18	TC	**			Test Control – for IBM modems (jumper needed).
20	DTR*CD	108.2		-->	Data Terminal Ready – Controls online modem switching. If high, prepares the modem for line connection, and to maintain the connection.
22	RI	CE	125		Ring Indicator – Not used.
23	RSEL	CH/CI	111/112	-->	Rate Select – Selects between two data-signalling rates in IBM-type dual-rate modems. Selected by the “Modem Rate” parameter of LCP Configure Host option (high if full speed, low if half speed).
25	TI	**			Test Indicator – Not used.

Signals not listed on this chart are not supported by the control unit.

* Maintenance port signals. These signals are the only signals supported by the maintenance port. RTS and DTR are always maintained at a high level. CTS and all other signals are ignored.

** IBM modem signals only (for test purposes). For IBM implementation, pins 14 and 7 are connected for V.35.

Table 2-3. RS 232C Communication Signal Definitions (Continued)

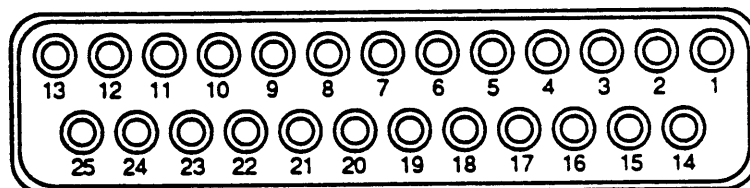

Figure 2-2. RS 232C Connector Pin Numbering

Pin #	Signal Name
1	Data in A
2	N/C
3	N/C
4	N/C
5	Data Out A
6	Data In B
7	N/C
8	N/C
9	Data Out B
Shield	Ground

Table 2-4. Token Ring Signal Definitions

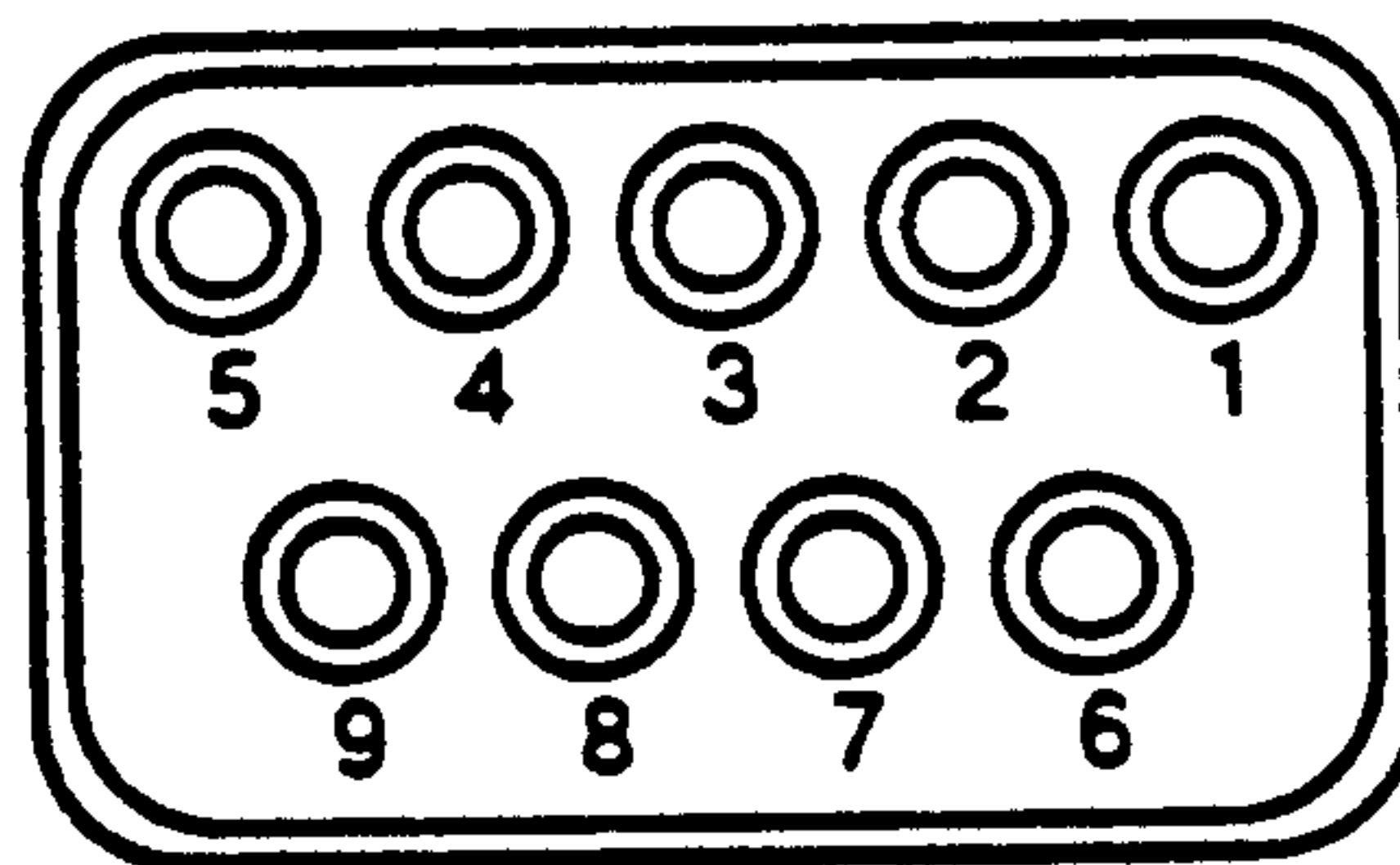

Figure 2-3. Token-Ring LAN Pin Numbering

HOST COMMUNICATIONS

Several parameters of the LCP CONFIGURE Host (CH) command must be compatible with the interface between the remote controller and the host processor (refer to the LCP description in the *1374 Configuration Guide*). The following text gives a description of each Configure Host parameter and its effect on the communications interface.

HOST COMMUNICATION

The following three Configure Host (CH) parameters are used to set the proper handshake controls with the host processor during link operation:

<u>Parameter</u>	<u>Link Feature</u>
Facility Connect	(Switched/Nonswitched)
Link Configuration	(Multipoint/Point-to-point)
Duplex Facility	(Full/Half)

SWITCHED VS. NONSWITCHED LINES

Switched lines are dial-up lines; nonswitched lines are dedicated, direct lines.

1374 (and IBM 3174) BSC systems do not support switched line operations. When a Facility Connect parameter of "Switched" is selected, the control unit responds at the link level the same as if the "Nonswitched" parameter had been selected. However, there should be no need to select the "Switched" parameter.

1374 SDLC systems may operate on either switched or nonswitched lines. Idle time-outs (no flag characters on the line in the past 20 to 25 seconds) are reported on the Operator Information Area (line 25) via the "Comm Chk 521" status display.

On nonswitched lines, any number of consecutive idle time-outs may occur without affecting the RS 232C interface. When operating with SDLC on a switched line, three consecutive idle time-outs (about 60 seconds elapsed time) will cause the control unit to break the line connection. The Data Terminal Ready (DTR) lead is dropped. DTR remains inactive until a drop of Data Set Ready (DSR) from the attached modem is detected. Once DSR has dropped, DTR will again be activated (about 100 milliseconds later) to allow the host connection to be reestablished at a later time.

MULTIPOINT VS. POINT-TO-POINT OPERATION

1374 multipoint operation implies that one or more control units are sharing the communication line to the host processor. 1374 point-to-point operation implies only one control unit is using the communication line to the host processor.

FULL-DUPLEX VS. HALF-DUPLEX OPERATION

Full-duplex operation implies that the physical communication line to the host processor is a 4-wire line, with transmitted data using one pair and received data using the second pair. Half-duplex operation implies that the physical communication line is a 2-wire line, with both transmitted and received data alternately sharing the pair.

NOTE: Regardless of the physical connection type, the 1374 software only operates as a logical half-duplex device (i.e., data is never transmitted and received simultaneously).

PARAMETER COMBINATIONS

The parameters defined above should be configured to provide optimal communication throughput between the host and the control unit, depending on the type of communication equipment available at the installation site.

When selected, communication link parameters interact with one another differently in different communications environments, as described next.

POINT-TO-POINT/FULL-DUPLEX OPERATION

Both BSC and SDLC systems will maintain the Request to Send (RTS) lead in the active (high) state at all times in order to avoid modem RTS-CTS turnaround delay times. An SDLC system idles flag (7E hex) characters on the line at all times unless transmitting data. A BSC system idles mark (FF hex) characters on the line.

POINT-TO-POINT/HALF-DUPLEX OPERATION

Both BSC and SDLC systems maintain the RTS lead in the active state only during transmission operations to the host. RTS is not active during receive operations from the host.

MULTIPOINT/HALF-DUPLEX OPERATION

Multipoint operation implies that the communication line may be shared between multiple control units. For this reason, an individual control unit may not leave its RTS lead in the active state permanently without eventually interfering with communications between the host and other control units on the line. BSC and SDLC systems maintain the RTS lead in the active state only during transmission operations to the host.

HOST COMMUNICATION

MULTIPOINT/FULL-DUPLEX OPERATION

An SDLC system operates the same as a multipoint/half-duplex line. The BSC control unit raises RTS from the time it responds to a host poll or select sequence until either the host or the control unit transmits an EOT sequence. During this time period, one or more messages may be sent to or from the host without the extra modem RTS-CTS handshake delay time being introduced.

SUMMARY OF LCP HOST COMMUNICATIONS PARAMETERS

The following charts summarize the LCP configuration parameters and the effects of the parameter combinations. Data Terminal Ready (DTR) and RTS are dropped (inactive low state) when the LCP Host Deactivate (HD) command is issued.

LCP Parameters			Controller Signals	
Link	Duplex	Facility	Request To Send (RTS)	Data Terminal Ready (DTR)
P to P	Full	Switched	* * * Undefined Parameter Combination (2)	* * *
to P	Full	Non-Sw.	Always High	Always High (1)
P to P	Half	Switched	High only during transmissions to Host	High Unless 3 consecutive Idle Time-outs occur (1.3)
P to P	Half	Non-Sw.	High only during transmissions to Host	Always High (1)
Multi	Full	Switched	* * * Undefined Parameter Combination (2)	* * *
Multi	Full	Non-Sw.	High only during transmissions to Host	Always High (1)
Multi	Half	Switched	High only during transmissions to Host	High Unless 3 consecutive Idle Time-outs occur (1.3)
Multi	Half	Non-Sw.	High only during transmissions to Host	Always High (1)

NOTES:

1. If DSR from the modem drops, the control unit drops DTR for about 100 milliseconds to assure disconnection from the modem. This condition will occur regardless of configuration parameters.
2. A switched network implies 2-wire facilities. Thus a full-duplex switched facility is undefined.
3. DTR is dropped until the modem drops DSR. Once DSR is dropped, DTR is brought back up after about 100 milliseconds.

Table 2-5. SDLC Communication Parameters and Signals

HOST COMMUNICATION

LCP Parameters			Controller Signals	
Link	Duplex	Facility	Request To Send (RTS)	Data Terminal Ready (DTR)
P to P	Full	Switched	* * * Undefined Parameter Combination (2) * * *	
P to P	Full	Non-Sw.	Always High	Always High (1)
P to P	Half	Switched	* * * Undefined Parameter Combination (2) * * *	
P to P	Half	Non-Sw.	High only during transmissions to Host	Always High (1)
Multi	Full	Switched	* * * Undefined Parameter Combination (2) * * *	
Multi	Full	Non-Sw.	High from Host Poll/Sel until Host or CU EOT (3)	Always High (1)
Multi	Half	Switched	* * * Undefined Parameter Combination (2) * * *	
Multi	Half	Non-Sw.	High only during transmissions to Host	Always High (1)

NOTES:

1. If DSR from the modem drops, the control unit drops DTR for about 100 milliseconds to assure disconnection from the modem. This condition will occur regardless of configuration parameters.
2. BSC does not support switched networks, therefore switched configurations are undefined. A switched line is treated the same as a nonswitched line.
3. RTS remains high from when the control unit receives a poll or select from the host until the control unit receives an end of text (EOT) from the host, or until the control unit sends an EOT to the host.

Table 2-6. BSC Communication Parameters and Signals

LCP LAN CONFIGURATION PARAMETERS

Additional LCP commands have been developed for configuring and managing the Token-Ring LAN. These commands appear when the control unit is equipped with the Token-Ring Adapter and the 1374 LAN software. The additional LCP commands are:

- Configure Subchannel
- Configure Host (downstream node)
- Display
- Display Host (downstream node)

HOST COMMUNICATION

- Subchannel Activate/Deactivate
- Network Manager
- Network Activate/Deactivate
- Network Parameters
- Network Statistics

For additional information about LCP and LCP LAN commands, refer to the *1374 LAN Operations Manual*.

Chapter 3

Site Planning and Management

SITE PLANNING AND MANAGEMENT

INTRODUCTION

All Memorex Telex control units are designed to be installed by the customer.

This chapter provides model-specific sections that describe the various planning and installation procedures for each series of control units in the 1374 family. Product-specific descriptions provide information about environmental, space, electrical, and host system requirements.

1374 MODEL 1L/1R/2R/3R

INSTALLATION REQUIREMENTS

The following discussion describes specific physical, environmental, and power requirements to consider when installing an 0X series control unit.

PHYSICAL DESCRIPTION

These floor-standing control units are designed for computer rooms or office environments. Dimensions and position of the operator panel are shown in the next figure.

The two unit doors are hinged and swing open for easy access to the inside of the unit. The door latches are the "press-to-release" type. You must press the door in to release the latch.

The disk drive is located behind the top door. This door has an inside pocket for storing up to six diskettes.

The coax and A/A ports are behind the lower door. The External Power Option (EPO) cable, power cable, and bus and tag channel cables attach at the back.

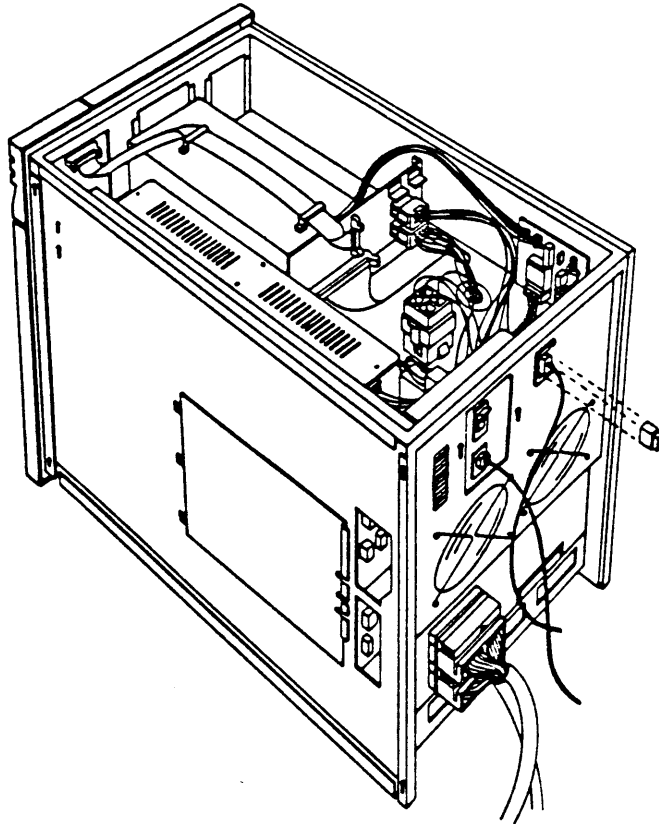

Figure 3-1. Model 1L With External Power Option (EPO)

OPERATOR CONTROL PANEL

The operator control panels are at the front. They consist of green LED power and status indicators, a power switch, and a channel online/offline switch. Model 1L offers an optional EPO selection on its power switches to select local or remote power control. Refer to the next figure.

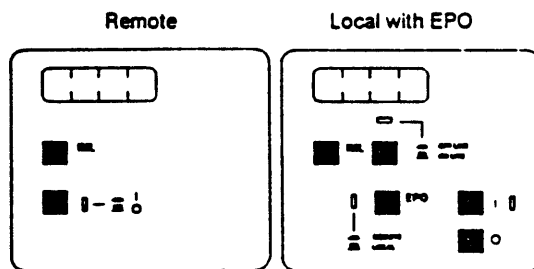

Figure 3-2. Model 1R/2R/3R and Model 1L Operator Control Panels

SITE PLANNING AND MANAGEMENT

1. **Power Indicator:** This green LED lights when power is turned on and the unit is operational.
2. **Power-On Switch:** Press the power-on switch to power the control unit on. Press again to power it off. The control unit is initialized and conducts self-tests when power is switched on.

Model 1L control units with EPO: The power switches on these units consist of two momentary switches – one On and one Off.

3. **Four-Digit Alphanumeric Indicator:** This 4-digit LED (e.g., “P080,” “P081”) indicates progress of power-on tests and system operation. During normal operation the indicators are blank. During power up and IML the indicators momentarily display test information. If this information remains in the indicators or appears during operation, refer to the *1374 Troubleshooting Guide*.
4. **Initial Microprogram Load (IML) Switch:** This switch initiates power-on reset that includes initialization of hardware, power-on diagnostics, and program load self-testing.

Model 1L IML switch will not reinitialize the channel adapter if the microcode has been loaded.

5. **Channel Online/Offline Switch:** This switch disables or enables the channel host interface.
6. **Channel Offline Indicator:** When the channel is offline via the Channel Online/Offline switch, the light is on.
7. **Diskette Drive:** The Select indicator lights up when the drive is selected.

For model 1L control units with EPO:

8. **EPO Selector:** This switch selects remote or local control of power to the control unit. Local control means power is controlled by the power-on switch on the control unit. Remote control means power is controlled from some point other than the control unit via the EPO cable.
9. **EPO Indicator:** This green LED is located to the left of the power switch. If EPO is remotely controlled, the light is on.
10. **Channel Priority:** Determine the setting of the channel priority select switch.

SITE PLANNING AND MANAGEMENT

CLEARANCES

Models 1L, 1R, 2R, and 3R require a 36-inch front and 30-inch rear maintenance clearance. Rear clearance must be maintained during normal operations to ensure adequate cooling. Refer to the next figure.

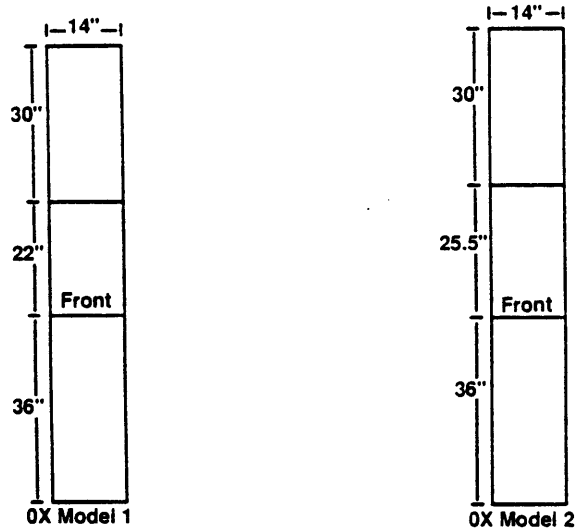

Figure 3-3. 1374-0X Series Clearances

COOLING

Cooling air is drawn from the lower front of the unit through the board assembly to the power supply and disk assembly at the top, and then exhausted by fans through the rear.

Under-floor air is not required but is suitable within the specified temperature and humidity limits. If cabling is routed through a floor opening in a raised-floor environment, sealing the opening is not necessary.

ACOUSTIC NOISE

All models produce very limited disk drive and fan noise. The disk drives are accessed only during power up or IML (Initial Micro-program Load). The noise level for each model is less than 55 dB.

ELECTRICAL REQUIREMENTS

POWER PLUGS AND RECEPTACLES

Domestic 120 VAC control units have nonlocking 125V/15A plugs (5-15P, NEMA) and use matching receptacles (5-15R, NEMA). Domestic 208 and 240 VAC model 1L control units are available.

International 220 VAC control units have nonlocking 250V/15A plugs determined by the country type: Continental Europe, United Kingdom, or Australia.

Ensure that the correct receptacle is available for the power plug ordered for your control unit.

POWER CORDS

For units set at 120V: Use a UL Listed type SJT cord, 3-conductor, rated 10A, 125V, not to exceed 15 feet in length (7.5-foot power cord is supplied with the control unit).

For units set at 220V (domestic): Use a UL Listed type SJT cord, 3-conductor, rated 6A, 250V, not to exceed 15 feet in length.

For units set at 220V (for use outside the U.S.): Use a 3-conductor cord, rated 6A, 250V with appropriate safety approvals for the country in which the equipment is to be installed.

The use of extension cords is not recommended.

HOST SYSTEM REQUIREMENTS

The host system requires specific preparation to support 0X series control units. If an IBM 3174 or equivalent control unit is being replaced with an 0X series control unit, these host requirements have been completed. If host preparation is required, assign a person familiar with the hardware/software configuration to plan and implement the following items:1.

1. System generation of terminal addresses

The I/O definition of the host system must be updated to reflect addition of new terminals to the system. If model 1L, 1R, 2R, or 3R is replacing an existing control unit and no other changes are being made, changes are probably not required. If this is a new control unit installation, or if other changes are made (such as attaching A/A devices), a new I/O definition is required. Implement changes prior to installation.

SITE PLANNING AND MANAGEMENT

2. **Model 1L:** Control unit channel priority

Model 1L is a fully data-buffered device and is not subject to data overruns. If other devices on the channel are subject to overrun, it may be desirable to set the control unit priority to a lower level than that of those devices. The priority select switch is located on the rear of the control unit, directly above the bus and tag cable connectors. Determine the priority setting of the control unit on the channel (Select Out = high, Select In = low) and inform the service representative prior to installation.

Model 1L: Unit Control Word (UCW) assignment

The host channel may require UCW and parameter assignments for the control unit. Both shared and unshared UCWs are supported on model 1L. Determine if these assignments are required and complete the action prior to installation. Consult your field representative for specific host channel requirements.

3. **Models 1R/2R:** Control unit address

Non-SNA Operation: The unit requires an 8-bit address, defined to models 1R and 2R as two remote configuration hexadecimal digits. Any *valid* address may be used as the first terminal address on the control unit. Assign contiguous terminal addresses, including the beginning address, for the models' devices. Addresses are determined by the type of operation (SDLC or BSC).

SNA Operation: Only a control unit address is required since terminal addresses are included in the SNA data stream. *Do not use FF hex.*

SETUP AND INSTALLATION PROCEDURES

The control unit is shipped with standard (or specified) cables and documentation. After unpacking the machine, complete the setup instructions to physically install the control unit, attach device cables, and begin configuration procedures.

Unpacking instructions are included in Appendix D. These instructions are also attached to the outside of the shipping container. Setup instructions are packed inside the shipping container.

HOST ATTACHMENT

CHANNEL ATTACHMENT

Model 1L supports SNA or non-SNA (3272-extended) operation. The unit may be attached to selector, byte multiplexer, or block multiplexer channels of IBM or compatible processors.

SITE PLANNING AND MANAGEMENT

Operation is byte mode or burst mode at data rates up to 1.25 MByte/second. Because of host system performance considerations, operation on selector channels or non-DCC (Disconnect Command Chaining) subchannels is not recommended.

BUS AND TAG CABLE REQUIREMENTS

Model 1L attaches to a host processor with IBM-type bus and tag cables. The control unit may be attached directly to the channel or to another control unit.

If new channel cables are required, the specific channel configuration and the distance between the model 1L and the host channel or next control unit must be considered. Standard 20-foot lengths are available; custom lengths may be requested.

Bus and tag cables enter the rear floor-level of the unit, from above or below the floor. One foot of cable is required from the entry point to the internal connectors.

If the channel unit is the last control unit on the channel, channel terminators must be moved to the model 1L control unit. No additional terminators are required.

The host cables are prepared by the customer as described in the Setup Instructions. The service representative will complete the bus and tag cable installation.

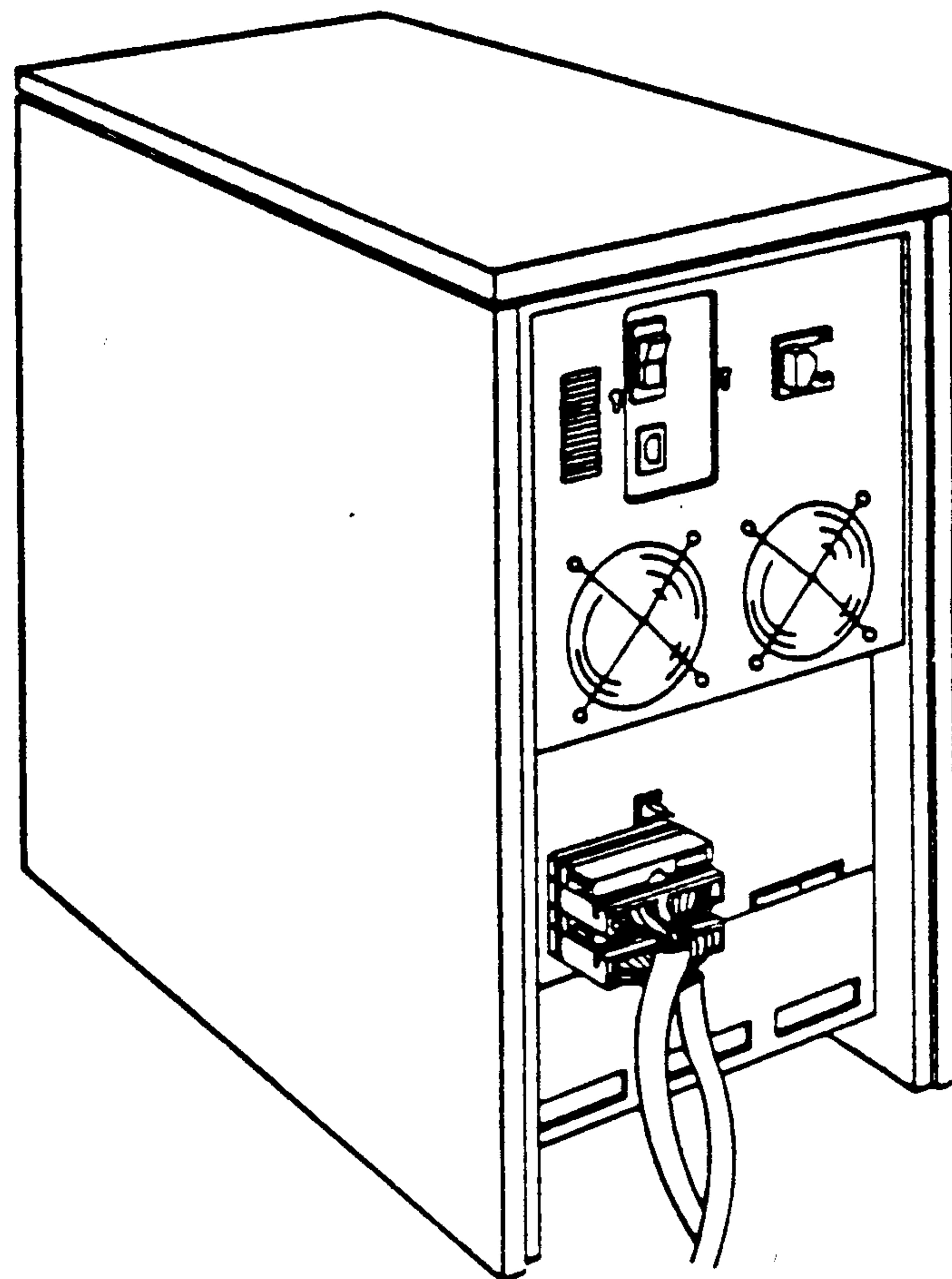

Figure 3-4. Bus and Tag Cable Setup

SITE PLANNING AND MANAGEMENT

EXTERNAL POWER OPTION (EPO) CABLE REQUIREMENTS

The customer must specify an EPO cable for model 1L with EPO. This cable allows the system and system console to control the power sequences of the control unit. The standard EPO cable length is 100 feet. EPO cables up to 200 feet are available by special order.

Some operations use the EPO arrangement while others control power locally at the control unit. Model 1L with EPO is shipped with an EPO bypass in the EPO connector, permitting local power control.

The service representative will complete the EPO cable installation.

COMMUNICATION ATTACHMENT

The customer is responsible for the installation of required modems and communication line facilities. These components must be compatible with the selected operating mode.

The following items should be considered: line speed, full-duplex/half-duplex, and Non-Return to Zero (NRZ)/Non-Return to Zero Inverted (NRZI). Specialists for the communication facility and control unit can assist in planning for these requirements.

Table 2-1 in this manual lists remote configurations for models 1R and 2R.

NOTE: Model 1R is compatible with IBM's implementation of combined RS 232C and V.35 (EIA/V.35) signals. For proper operation, use the communications cable supplied with the control unit.

MODEM SUPPORT

Modems are not supplied with the control units. Any modem that meets 3270 specifications may be used. The customer is responsible for maintaining the modems and all attached communications lines.

A standard 20-foot communications cable is supplied with these models for modem attachment. Alternative lengths of 10, 30, and 40 feet may be specified. Only these modem cables should be attached to the control unit. Do not use a cable longer than 40 feet.

Instructions detailing how to attach the modem cable to the control unit are included in the Setup Instructions.

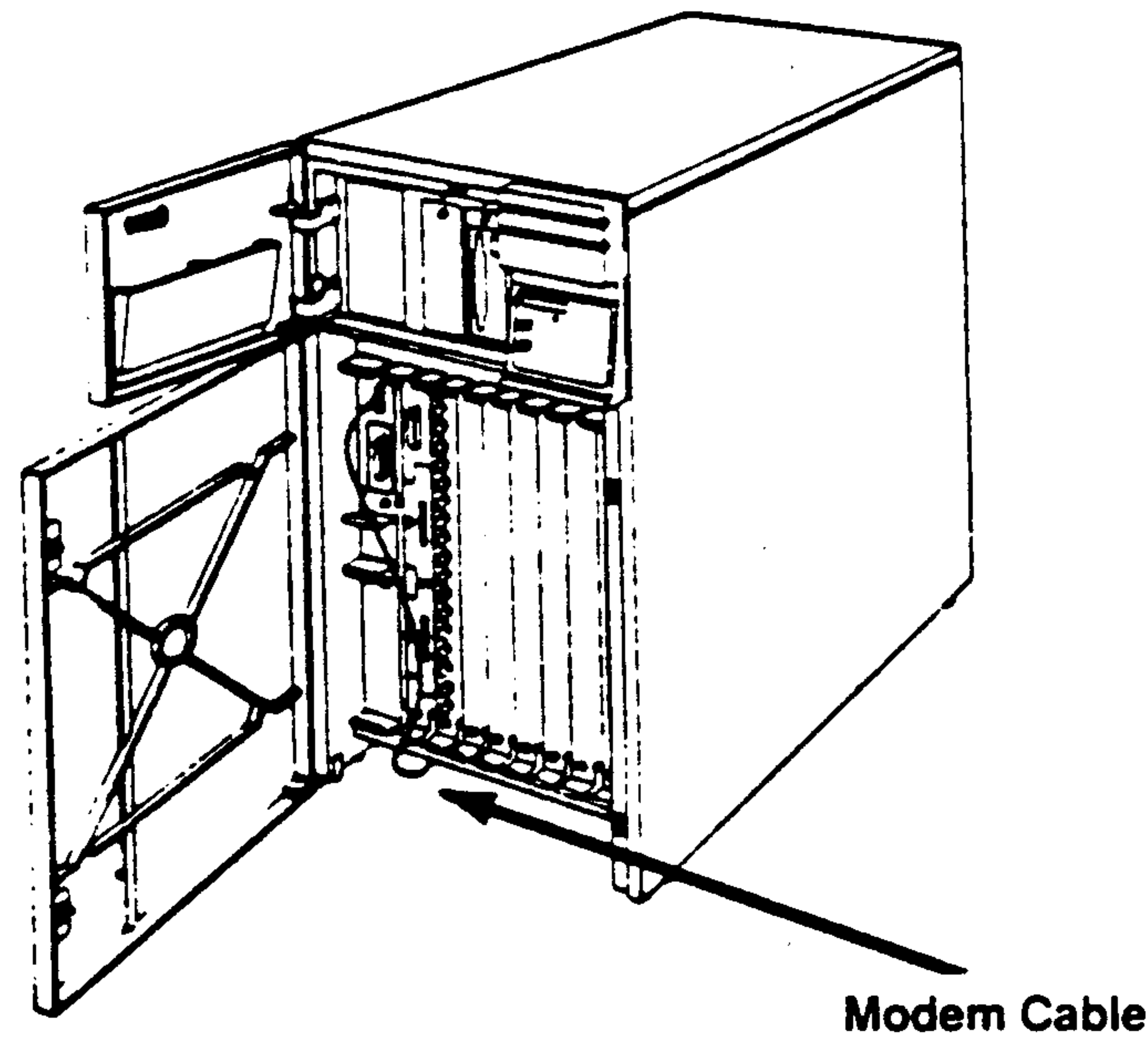

Figure 3-5. Communications Cable Setup

COAX DEVICE ATTACHMENT

Coax displays and printers are attached to 1374 control units with dual-purpose BNC connectors that support standard coaxial connections or connections to the IBM cabling system. Any supported device that has been connected to an IBM 3174 or compatible control unit may be attached.

COAX CABLE REQUIREMENTS

The required device cable is commercially designated as RG 62A/U. Local regulations may require a special type of outside covering such as outdoor-/weather-proof, fire-retardant, and/or plenum rated fire-/smoke-retardant. For additional information, refer to the installation manuals for the attached devices or to related IBM documentation.

Devices may be installed up to 4,920 feet (1,500 meters) from the control unit. The customer is responsible for procuring, installing, and maintaining coaxial cables and connectors.

Device cables are attached inside the front cabinet. For above-floor installations, cables enter the unit at the rear floor level.

For raised-floor installations, cables enter the left side of the cabinet at floor level. Thirty inches of cable are required inside the cabinet for above-floor installations and 18 inches for raised-floor cabling.

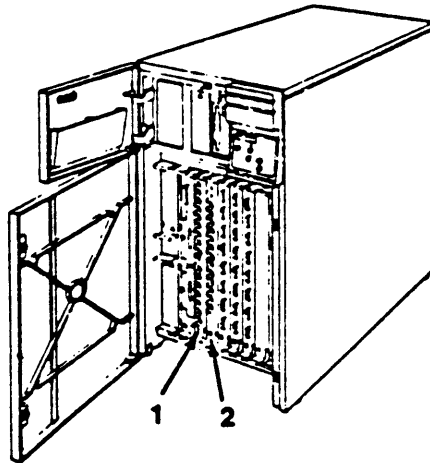

Figure 3-6. 1374-0X Series Coax Device Attachment

1. Coax Adapter with ports for up to 18 direct-attached coax devices or any combination of direct-attached and multiplexed coax devices up to a maximum of 32.
2. Sixteen-Port Coax Extender Adapter with ports for 16 direct-attached coax devices or any combination of direct-attached and multiplexed coax devices up to a maximum of 32.

COAX MULTIPLEXER

The coax multiplexer attaches to 0X series control units via coax cable, telephone twisted-pair cable, or IBM cabling system types 1, 3, and 9. The Dual-Purpose Connector (DPC) on the rear of the multiplexer eliminates the need to use baluns, which balance the signals for transmission from terminals and peripherals.

The multiplexer can be attached to any of the ports on the control unit.

DYNAMIC MULTIPLEXER COAX PORT MAPPING

Dynamic Multiplexer Coax Port Mapping allows any port to have either a direct attached device or from two to eight multiplexed devices. The total number of logical ports for the controller is limited to 32. The LCP Configure Multiplexer command (CW) is used to define the logical ports associated with each physical coax connector. The LCP commands continue to use the logical port number as an index into device control blocks and configuration tables.

SITE PLANNING AND MANAGEMENT

In the next figure, the first column of the screen contains the physical port numbers that correspond to the connectors on the controller. These numbers are always displayed sequentially. The number of physical ports displayed is the maximum number connected to the controller, even if there is not a coax extender present on the system. The second column is a list of all logical ports associated with a physical port. The first logical port in the list can either be directly attached, or connected to address 0 on a multiplexer. Subsequent logical ports on the list are attached to multiplexer at addresses 1, 2, and so on.

A logical port can appear twice on the LCP CW screen, but it can only appear once as the first logical port in a list. When the controller detects a valid device in either of the two locations, the other location for that logical port is disabled. It is possible that there may be physical ports without any logical ports and, conversely, that there are logical ports that are not assigned to a physical port.

====>C CW

Modify panel and ENTER, or use PF3 to exit

<u>Physical Port</u>	<u>Logical Port(s)</u>	<u>Physical Port</u>	<u>Logical Port(s)</u>
0	0 1 2 3 4 5 6 7	16	16 17 18 19 20 21 22 23
1	1	17	17
2	2	18	18
3	3	19	19
4	4	20	20
5	5	21	21
6	6	22	22
7	7	23	23
8	8 9 10 11 12 13 14 15	24	24 25 26 27 28 29 30 31
9	9	25	25
10	10	26	26
11	11	27	27
12	12	28	28
13	13	29	29
14	14	30	30
15	15	31	31

Figure 3-7. 0X Default Configuration

The next two figures show examples of two possible ways that the logical ports can be configured.

SITE PLANNING AND MANAGEMENT

```
====> CW
Modify panel and ENTER, or use PF3 to exit
```

<u>Physical Port</u>	<u>Logical Port(s)</u>	<u>Physical Port</u>	<u>Logical Port(s)</u>
0	0 1 2 3 4 5 6 7	16	
1	8 9 10 11 12 13 14 15	17	
2	16 17 18 19 20 21 22 23	18	
3	24 25 26 27 28 29 30 31	19	
4	4	20	
5	5	21	
6	6	22	
7	7	23	
8		24	
9		25	
10		26	
11		27	
12		28	
13		29	
14		30	
15		31	

Figure 3-8. Sample Configuration Ports 0 Through 3

```
====>C CW
Modify panel and ENTER, or use PF3 to exit
```

<u>Physical Port</u>	<u>Logical Port(s)</u>	<u>Physical Port</u>	<u>Logical Port(s)</u>
0	0	16	
1	1	17	
2	2	18	
3	3	19	
4	4	20	
5	0 1 2 3 4 5 6 7	21	
6	8 9 10 11 12 13 14 15	22	
7	16 17 18 19 20 21 22 23	23	
8	24 25 26 27 28 29 30 31	24	
9		25	
10		26	
11		27	
12		28	
13		29	
14		30	
15		31	

Figure 3-9. Sample Configuration Ports 5 Through 8

SITE PLANNING AND MANAGEMENT

1374 DISKETTES

Control unit operational and diagnostic software, stored on 3.5-inch diskettes, is loaded from the disk drive. The diskette label must be facing left when the diskette is inserted into the disk drive. The system diskette should remain in the drive at all times. Disk drive access occurs only after power-on tests have been successfully completed and the system is initialized. The access light on the disk drive panel lights during control unit IML.

STANDARD DISKETTES

0X series control units include the following standard diskettes:

- System: contains network architecture and system protocol
- Utility: provides specialized offline utility programs
- Standard Language: contains non-RPQ languages

The next table shows the diskettes required for each 0X series control unit.

Diskette Type	1L	1R	2R	3R
System				
Non-SNA	X			
SNA/SDLC	X			
SNA/SDLC		C	C	
BSC		X		
X.25		C	C	
SNA, LAN Gateway	X			
SNA, LAN Gateway		C	C	
LAN Interface				X
Utility	C	C	C	C
Standard Language	C	C	C	C

X = One diskette per model type
C = Common to models indicated

The Dual SNA/SDLC Host option is supported on the SDLC System Diskette.

Table 3-1. Standard Diskettes – 0X Series

SITE PLANNING AND MANAGEMENT

SPECIAL SYSTEM DISKETTES

Certain Dual-Host options require special system diskettes, which are supplied with the option. These diskettes are:

<u>Diskette Type</u>	<u>1L</u>	<u>1R</u>	<u>2R</u>	<u>3R</u>
Dual Mixed Host (SNA/SDLC and BSC)		X		
Dual Mixed Host (Local/Remote)	X			
Dual Mixed Host (Local/Remote) and TR Gateway	X			

Table 3-2. Special System Diskettes – 0X Series

OPTIONAL DISKETTES

The following diskettes are optionally available for 0X series control units:

<u>Diskette Type</u>	<u>1L</u>	<u>1R</u>	<u>2R</u>	<u>3R</u>
ACS and Mixed Host (Local/Remote)	X			
ACS and Mixed Host (SNA/SDLA and BSC)		X		
ACS and Token-Ring Gateway				
Diagnostics	C	C	C	C
Dump	C	C	C	C
RPQ Language	C	C	C	C

Table 3-3. Optional Diskettes – 0X Series

SITE PLANNING AND MANAGEMENT

ACS Diskettes (2): In addition to the dual host and token ring functions listed, the first diskette contains the Asynchronous Communications Support functions used to configure the control unit for Asynchronous/ASCII (A/A) terminal, printer, and host support. The other diskette, which runs on a PC, contains the PC emulation code. The ACS option requires an optional second disk drive.

Diagnostics Diskette: contains the 1374 diagnostics software.

Dump Diskette: contains the software and the space necessary to perform a memory dump of the control unit memory.

RPQ Language Diskette: contains the RPQ languages.

BOARD CONFIGURATION

The following table shows which PCBs may be plugged into the option slots for the 0X control units. Refer to Chapter 4, "User-Installable Options," for additional details.

Slot Number	Description
E	Host Serial Interface Extender
F	not used
0	Processor PCB
1	Coax Adapter (CA), Asynchronous Adapter (AA), Token-Ring Adapter (TRA), Token-Ring Gateway (TRGATE)
2	CA, AA, TRA, TRGATE, Coax Extender Adapter (CEA)
3	CA, AA, TRA, TRGATE, CEA
4	AA, TRA, TRGATE, CEA
5	AA, TRA, TRGATE
6	AA, TRA, TRGATE
7	Host Channel Adapter (HCA), AA, TRA, TRGATE

Table 3-4. PCB/Slot Guide

NOTE: 1. The two half-slots are labeled Slots E and F. The bottom half-slot (Slot F) is reserved for future use.

SITE PLANNING AND MANAGEMENT

2. If a CA and CEA are installed, the CEA must be installed in the next higher-numbered slot immediately adjacent to the CA. As an example, if the CA is installed in slot 2, the CEA must be installed in slot 3.
3. If the HCA is installed (1L), it must be installed in slot 7.
4. Make sure asynchronous port numbers are not changed when installing or removing A/A PCBs. The processor assigns the lowest asynchronous port numbers (ports 32 to 39) to the AA PCB installed in the lowest-numbered slot, the next eight port numbers (ports 40 to 47) to the AA PCB installed in the next lowest slot number, etc. Removing an AA PCB from the lowest-numbered slot causes the port numbers for remaining AA PCBs to decrease by eight. Installing an AA PCB in a lower-numbered slot than AA PCBs already installed increases the port numbers for the installed PCBs by eight.

1374 MODEL 41R/42R/43R

INSTALLATION REQUIREMENTS

The following discussion describes specific physical, environmental, and power requirements to consider before installing a 4XR series control unit.

PHYSICAL DESCRIPTION

These tabletop control units are designed for computer rooms or office environments. Overall physical dimensions and the position of the operator panel are shown in the next figure.

The front panel consists of the power switch, power indicator, and 4-segment status display. The disk drive, diskette storage pocket, and IML switch are located behind the front door. The diskette storage pocket will store several diskettes. The front door is hinged at the base and may be opened by firmly pulling the door panel at the top.

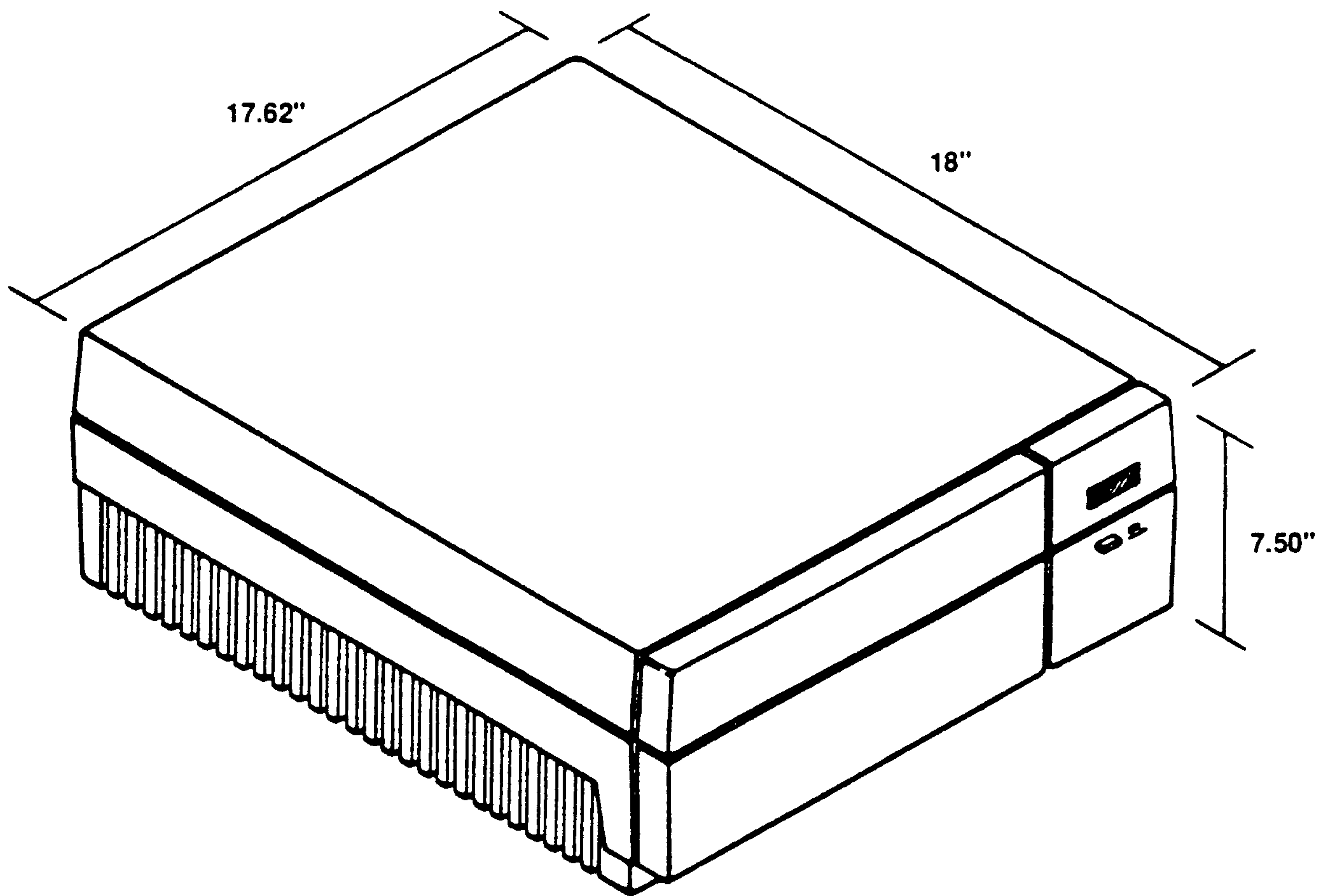

Figure 3-10. 1374 Model 4XR

OPERATOR CONTROL PANEL

The operator control panel consists of a power switch, and green LED power and status indicators.

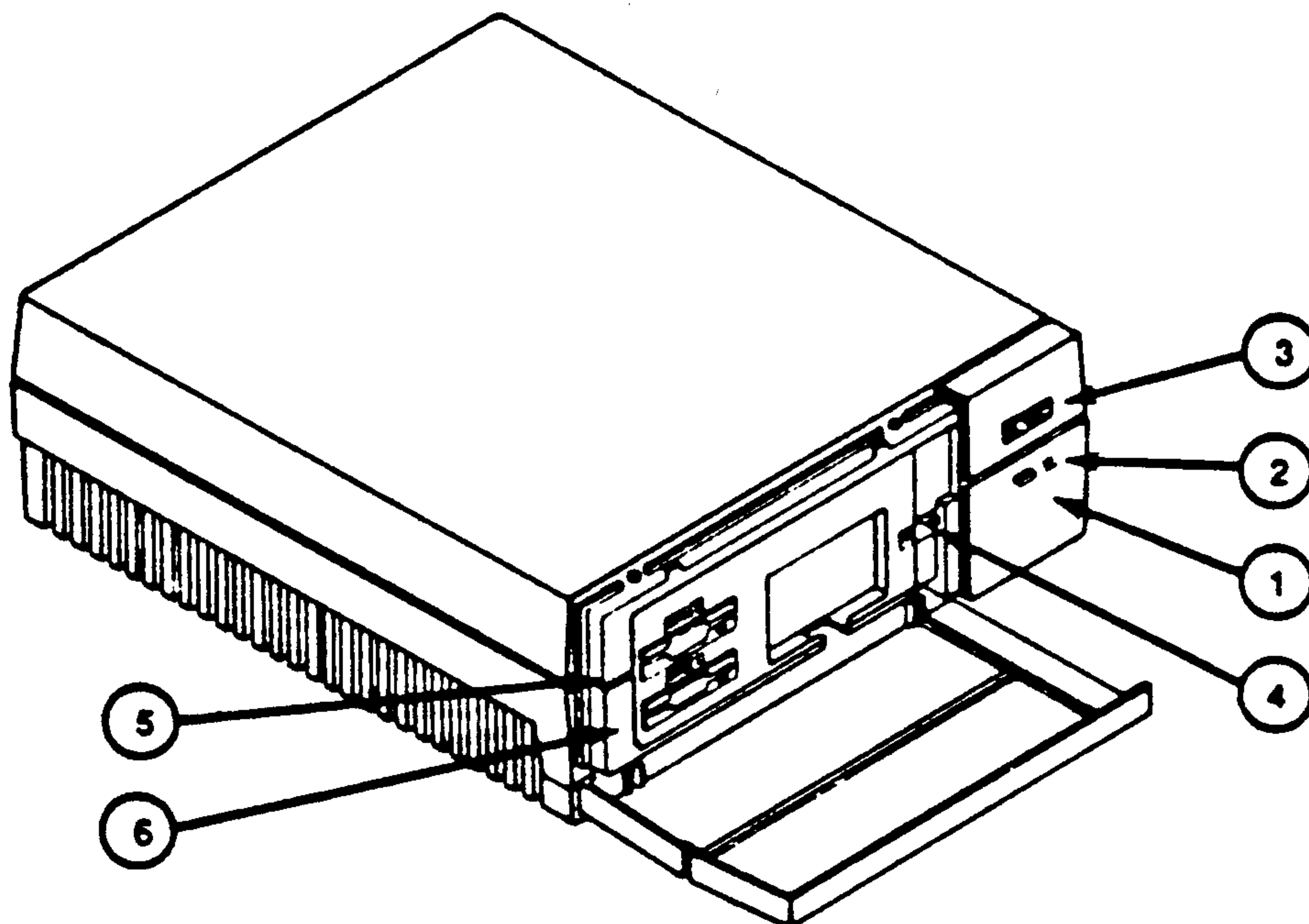

Figure 3-11. 1374 Model 4XR Operator Controls

SITE PLANNING AND MANAGEMENT

1. **Power-On Switch:** Press the power-on switch to power the control unit on. Press it again to power the control unit off. The control unit is initialized and conducts self-tests when power is switched on.
2. **Power Indicator:** This green LED lights when power is switched on and the control unit is operational.
3. **Four-Digit Alphanumeric Indicator:** This 4-digit LED (e.g., "P080," "P081") indicates the progress of the power-on tests and system operation. During normal operation, the indicators are blank. During power up and IML, the indicators momentarily display test information. If this information remains in the indicators or appears during operation, refer to the *1374 Troubleshooting Guide*.
4. **Initial Microprogram Load (IML) Switch:** This switch initiates power-on reset that includes initialization of hardware, power-on diagnostics, and program load self-testing.
- 5/6. **Diskette Drive:** The Diskette Drive Access Indicator lights when information is read from or written to a diskette. The power connector, voltage selector, coax and A/A ports, and host adapter are located on the rear panel.

BACKPANEL

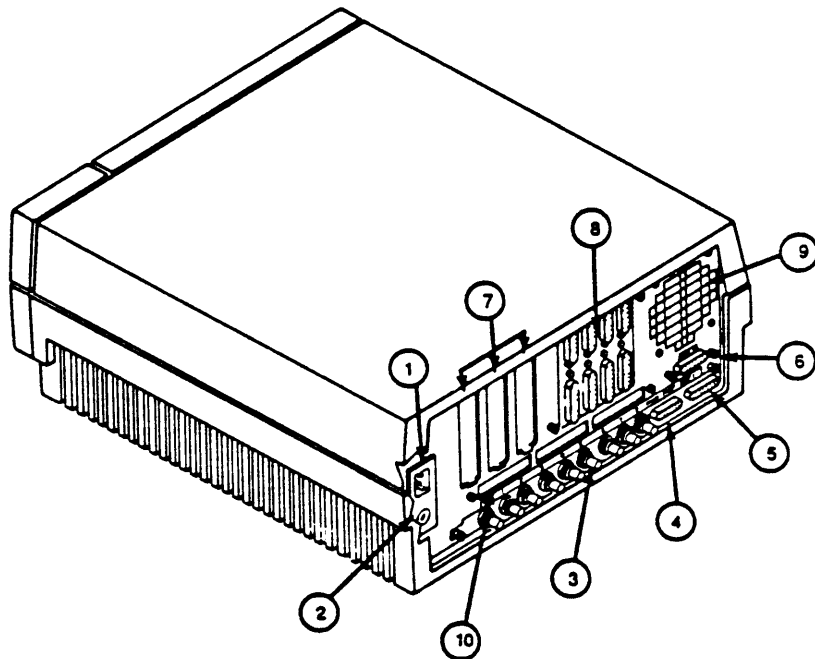

Figure 3-12. Typical 1374 Model 4XR Back Panel

1. Power Cord Connector
2. Voltage Selection Switch
3. Coax/Twisted-Pair Cable port
4. Maintenance Port
5. Host 1
6. Host 2
7. General-Purpose Option Slots
8. Asynchronous Adapter Connector Panel
9. Cooling Fan
10. Coax Extender Adapter Filler Panel

CLEARANCES

4XR series control units require a 3-inch left- and right-side and 6-inch rear ventilation and maintenance clearance. Rear clearance must be maintained during normal operations to ensure adequate cooling and space for coax cable attachment. Refer to the following figure:

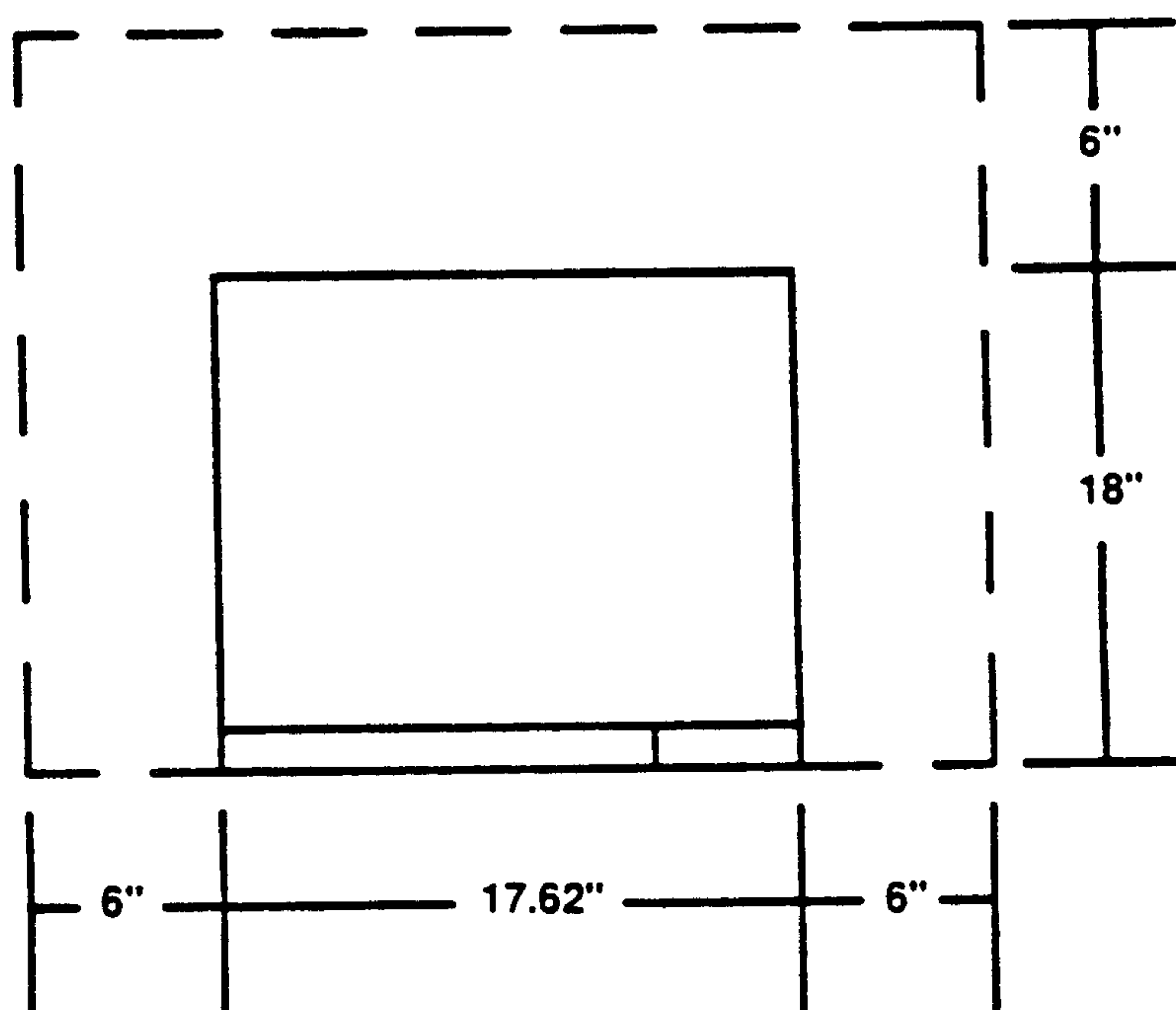

Figure 3-13. 1374 Model 4XR Clearances (Top-Down View)

SITE PLANNING AND MANAGEMENT

COOLING

Cooling air is drawn from the right side of the unit through the chassis and then exhausted by a fan through the upper left corner of the rear panel.

ACOUSTIC NOISE

All models produce very limited disk drive and fan noise. The disk drives are accessed only during power up or IML (Initial Micro-program Load). The noise level for each model is less than 55 dB.

ELECTRICAL REQUIREMENTS

POWER PLUGS AND RECEPTACLES

Domestic 120 VAC control units have nonlocking 125V/15A plugs (5-15P, NEMA) and use matching receptacles (5-15R, NEMA).

International 220 VAC control units have nonlocking 250V/15A plugs determined by the country type: Continental Europe, United Kingdom, or Australia.

Ensure that the correct receptacle is available for the power plug ordered for your control unit.

POWER CORDS

For units set at 120V: Use a UL Listed type SJT cord, 3-conductor, rated 10A, 125V, not to exceed 15 feet in length (7.5-foot cord is shipped with the control unit).

For units set at 220V (domestic): Use a UL Listed type SJT cord, 3-conductor, rated 6A, 250V, not to exceed 15 feet in length.

For units set at 220V (for use outside the U.S.): Use a 3-conductor cord, rated 6A, 250V with appropriate safety approvals for the country in which the equipment is to be installed.

The use of extension cords is not recommended.

HOST SYSTEM REQUIREMENTS

The host system requires specific preparation to support 1374-4XR control units. If an IBM 3174 or equivalent control unit is being replaced with a 1374-4XR series control unit, these host requirements have been completed. If host preparation is required, assign a person familiar with the hardware/software configuration to plan and implement the following items:

SITE PLANNING AND MANAGEMENT

1. System generation of terminal addresses

Update the I/O definition of the host system to reflect the addition of new terminals to the system. If a 4XR control unit is replacing an existing control unit and no other changes are being made, changes are probably not required. If this is a new control unit installation, or if other changes are made (such as attaching A/A devices), a new I/O definition is required. Implement changes prior to installation.

2. Models 41R/42R: Control unit address

Non-SNA Operation: The unit requires an 8-bit address, defined to 1374 models 41R and 42R as two remote configuration hexadecimal digits. Addresses are determined by the type of operation (SDLC or BSC).

Any *valid* address except FF hex may be used as the first terminal address on the control unit. Assign contiguous terminal addresses, including the beginning address, for the models' devices.

SNA Operation: Only a control unit address is required since terminal addresses are included in the SNA data stream. *Do not use FF hex.*

3. Model 43R: Control unit address

The LAN address is a 6-byte, 12-digit address.

SETUP AND INSTALLATION PROCEDURES

The control unit arrives with standard (or specified) cables and documentation. After unpacking the control unit, complete the setup instructions required to install the control unit, attach the device cables, and begin configuration procedures.

Unpacking instructions are included in Appendix D. These instructions are also attached to the outside of the shipping container. Setup instructions are packed inside the container.

HOST ATTACHMENT

The customer is responsible for the installation of required modems and communication line facilities. These components must be compatible with the selected operating mode.

COMMUNICATION ATTACHMENT

The following items should be considered: line speed, full-duplex/half-duplex, and Non-Return to Zero (NRZ)/Non-Return to Zero Inverted (NRZI). Specialists for the communication facility and control unit can assist in planning for these requirements.

SITE PLANNING AND MANAGEMENT

Table 2-1 in this manual lists remote configurations for models 41R, and 42R.

NOTE: Model 41R is compatible with IBM's implementation of combined RS 232C and V.35 (EIA/V.35) signals. For proper operation, use the communications cable supplied with the control unit. Do not use MC74 or 3274 cables.

MODEM SUPPORT

Modems are not supplied with the control units. Any modem that meets 3270 specifications may be used. The customer is responsible for maintaining the modems and all attached communications lines.

A standard 20-foot communications cable is supplied with these models for modem attachment. Alternative lengths of 10, 30, and 40 feet may be specified. Only these modem cables should be attached to the control unit. Do not use a cable longer than 40 feet.

Instructions detailing how to attach the modem cable to the control unit are included in the Setup Instructions.

COAX DEVICE ATTACHMENT

Coax displays and printers are attached to 1374 control units with dual-purpose BNC connectors that support standard coaxial connections or connections to the IBM cabling system. Any supported device that has been connected to an IBM 3174 or compatible control unit may be attached to a 4XR control unit.

COAX CABLE REQUIREMENTS

The required device cable is commercially designated as RG 62A/U. Local regulations may require a special type of outside covering such as outdoor-/weather-proof, fire-retardant, and/or plenum rated fire-/smoke-retardant. For additional information, refer to the installation manuals for the attached devices or to related IBM documentation.

Devices may be installed up to 4,920 feet (1,500 meters) from the control unit. The customer is responsible for procuring, installing, and maintaining coaxial cables and connectors.

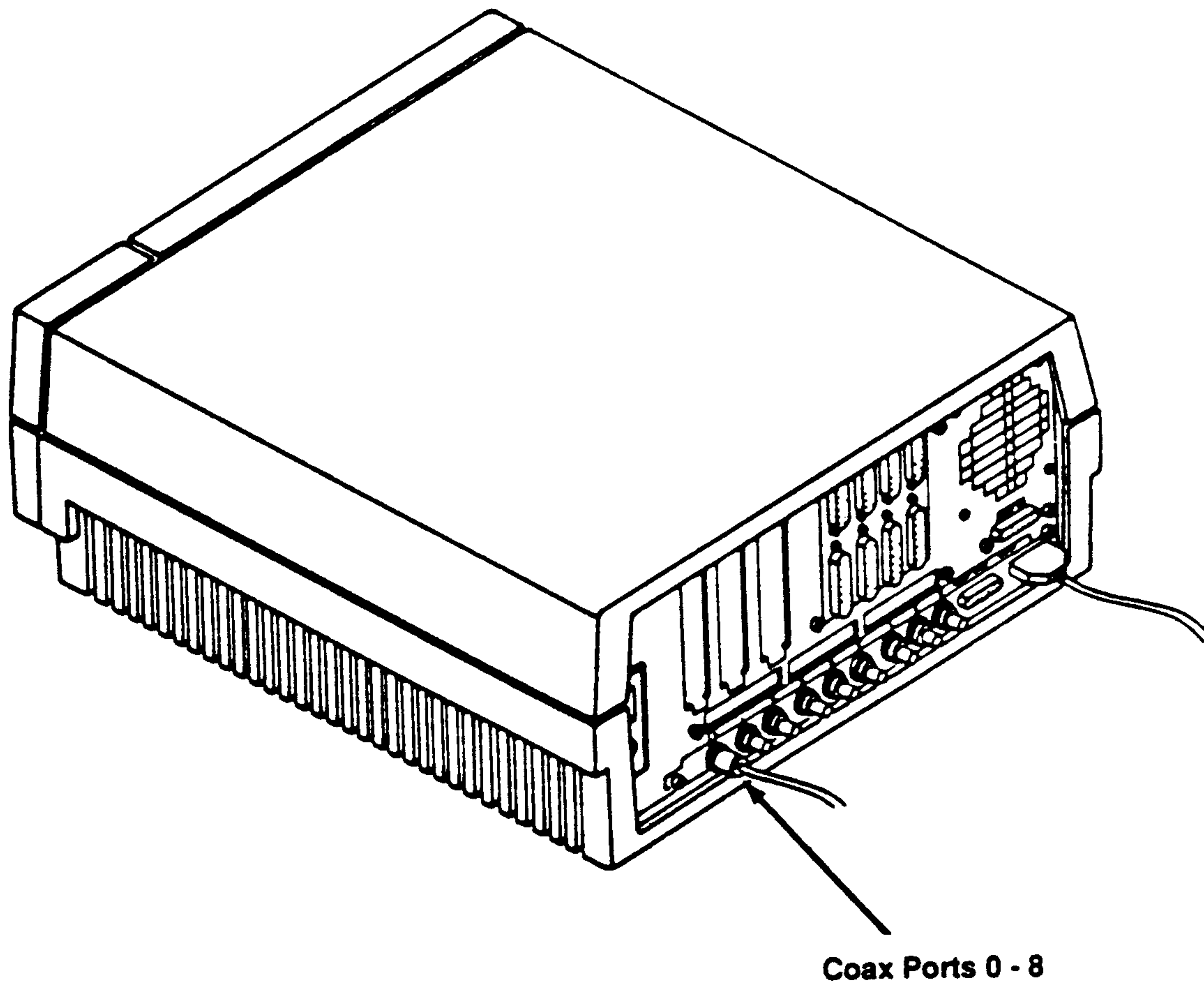

Figure 3-14. 1374 Model 4XR Coax Device Attachment

COAX MULTIPLEXER

The coax multiplexer attaches to 4XR series control units via coax cable, telephone twisted-pair cable, or IBM Cabling System types 1, 3, and 9. The Dual-Purpose Connector (DPC) on the rear of the multiplexer eliminates the need to use baluns, which balance the signals for transmission from terminals and peripherals.

The multiplexer can be attached to any of the ports on the control unit.

DYNAMIC MULTIPLEXER COAX PORT MAPPING

Dynamic Multiplexer Coax Port Mapping allows any port to have either a direct attached device or from two to eight multiplexed devices. The total number of logical ports for the controller is limited to 32. The LCP Configure Multiplexer command (CW) is used to define the logical ports associated with each physical coax connector. The LCP commands continue to use the logical port number as an index into device control blocks and configuration tables.

SITE PLANNING AND MANAGEMENT

In the next figure, the first column of the screen contains the physical port numbers that correspond to the connectors on the controller. These numbers are always displayed sequentially. The number of physical ports displayed is the maximum number connected to the controller, even if there is not a coax extender present on the system. The second column lists all logical ports associated with a physical port. The first logical port in the list can either be directly attached, or connected to address 0 on a multiplexer. Subsequent logical ports on the list are attached to multiplexer at addresses 1, 2, and so on.

A logical port can appear twice on the LCP CW screen, but it can only appear once as the first logical port in a list. When the controller detects a valid device in either of the two locations, the other location for that logical port is disabled. It is possible that there may be physical ports without any logical ports and, conversely, that there are logical ports that are not assigned to a physical port.

```
====>C CW
Modify panel and ENTER, or use PF3 to exit
```

<u>Physical Port</u>	<u>Logical Port(s)</u>	<u>Physical Port</u>	<u>Logical Port(s)</u>
0	0 1 2 3 4 5 6 7	16	16 17 18 19 20 21 22 23
1	1	17	
2	2		
3	3		
4	4		
5	5		
6	6		
7	7		
8	8 9 10 11 12 13 14 15		
9	9		
10	10		
11	11		
12	12		
13	13		
14	14		
15	15		

Figure 3-15. Default Configuration

The next two figures show examples of two possible ways that the logical ports can be configured.

SITE PLANNING AND MANAGEMENT

====> CW
Modify panel and ENTER, or use PF3 to exit

Physical Port	Logical Port(s)	Physical Port	Logical Port(s)
0	0 1 2 3 4 5 6 7	16	
1	8 9 10 11 12 13 14 15	17	
2	16 17 18 19 20 21 22 23		
3	24 25 26 27 28 29 30 31		
4	4		
5	5		
6	6		
7	7		
8			
9			
10			
11			
12			
13			
14			
15			

Figure 3-16. Sample Configuration Ports 0 Through 3

====>C CW
Modify panel and ENTER, or use PF3 to exit

Physical Port	Logical Port(s)	Physical Port	Logical Port(s)
0	0	16	
1	1	17	
2	2		
3	3		
4	4		
5	0 1 2 3 4 5 6 7		
6	8 9 10 11 12 13 14 15		
7	16 17 18 19 20 21 22 23		
8	24 25 26 27 28 29 30 31		
9			
10			
11			
12			
13			
14			
15			

Figure 3-17. Sample Configuration Ports 5 Through 8

SITE PLANNING AND MANAGEMENT

1374 DISKETTES

Control unit operational and diagnostic software, stored on 3.5-inch diskettes, is loaded from the disk drive. The diskette label must be facing up when the diskette is inserted into the disk drive. The system diskette should remain in the drive at all times. Disk drive access occurs only after power-on tests have been successfully completed and the system is initialized. The access light on the disk drive panel lights up during control unit IML.

STANDARD DISKETTES

4XR series control units include the following standard diskettes:

- System: contains network architecture and system protocol
- Utility: provides specialized offline utility programs
- Standard Language: contains non-RPQ languages

The next table shows the diskettes required for each control unit in the 1374-4XR series.

<u>Diskette Type</u>	<u>41R</u>	<u>42R</u>	<u>43R</u>
System			
SNA/SDLC	C	C	
BSC	X		
X.25	C	C	
SNA, LAN Gateway	C	C	
LAN Interface			X
Utility	C	C	C
Standard Language	C	C	C

X = One diskette per model type

C = Common to models indicated

The Dual SNA/SDLC Host option is supported on the SDLC System Diskette.

Table 3-5. Standard Diskettes – 4XR Series

SPECIAL SYSTEM DISKETTES

Certain Dual-Host functions require special system diskettes, which are supplied with the option. These diskettes are:

Diskette Type	4R	42R	43R
Dual Mixed Host (SNA/SDLC and BSC)	X		
Dual SNA/SDLC Host and TR Gateway	X	X	

Table 3-6. Special System Diskettes – 4XR Series

OPTIONAL DISKETTES

The following diskettes are optionally available for 4XR series control units:

Diskette Type	41R	42R	43R
ACS	C	C	C
ACS & Dual Mixed Host (SNA/SDLC and BSC)	X		
Diagnostics	C	C	C
Dump	C	C	C
RPQ Language	C	C	C

Table 3-7. Optional Diskettes – 4XR Series

ACS Diskettes (2): In addition to the dual host and token ring functions listed, the first diskette contains the Asynchronous Communications Support functions used to configure the control unit for Asynchronous/ASCII (A/A) terminal, printer, and host support. The other diskette, which runs on a PC, contains the PC emulation code. The ACS option requires an optional second disk drive.

Diagnostics Diskette: contains the 1374 diagnostics software.

Dump Diskette: contains the software and the space necessary to perform a memory dump of the control unit memory.

RPQ Language Diskette: contains the RPQ languages.

SITE PLANNING AND MANAGEMENT

1374 MODEL 51R/52R/53R

INSTALLATION REQUIREMENTS

The following discussion describes specific physical, environmental, and power requirements to consider before installing the control unit.

PHYSICAL DESCRIPTION

These tabletop control units are designed for computer rooms or office environments. Dimensions and position of the operator panel are shown in the next figure.

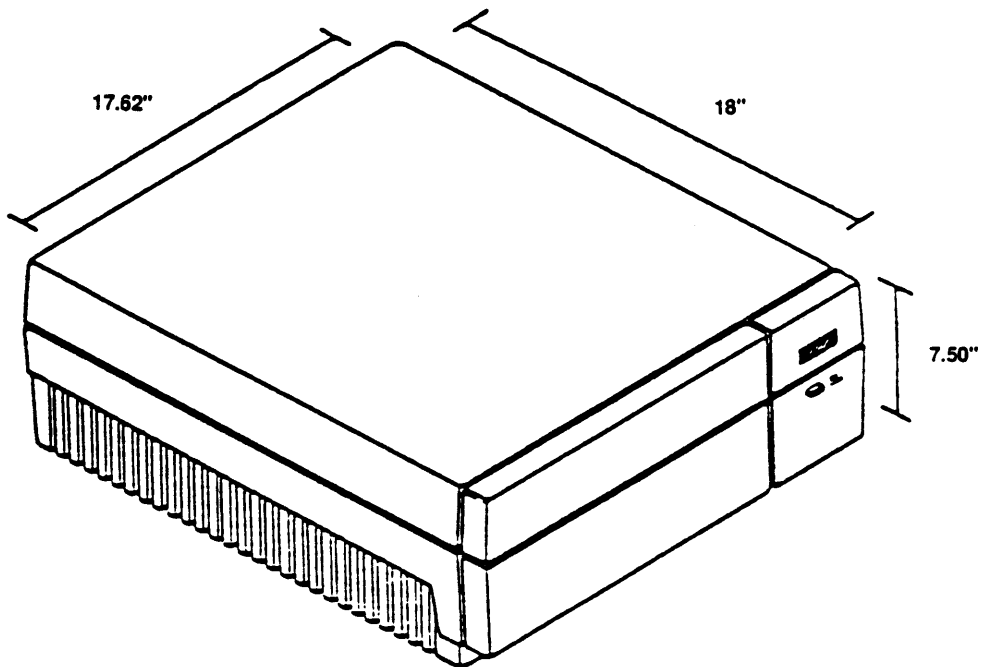

Figure 3-18. 1374 Model 5XR Control Unit

The front panel consists of the power switch, power indicator, and 4-segment status display. The disk drive, diskette storage pocket, and IML switch are located behind the front door. The diskette storage pocket will store up to six diskettes. The front door is hinged at the base and may be opened by firmly pulling the door panel at the top.

OPERATOR CONTROL PANEL

The operator control panel consists of a power switch, and green LED power and status indicators.

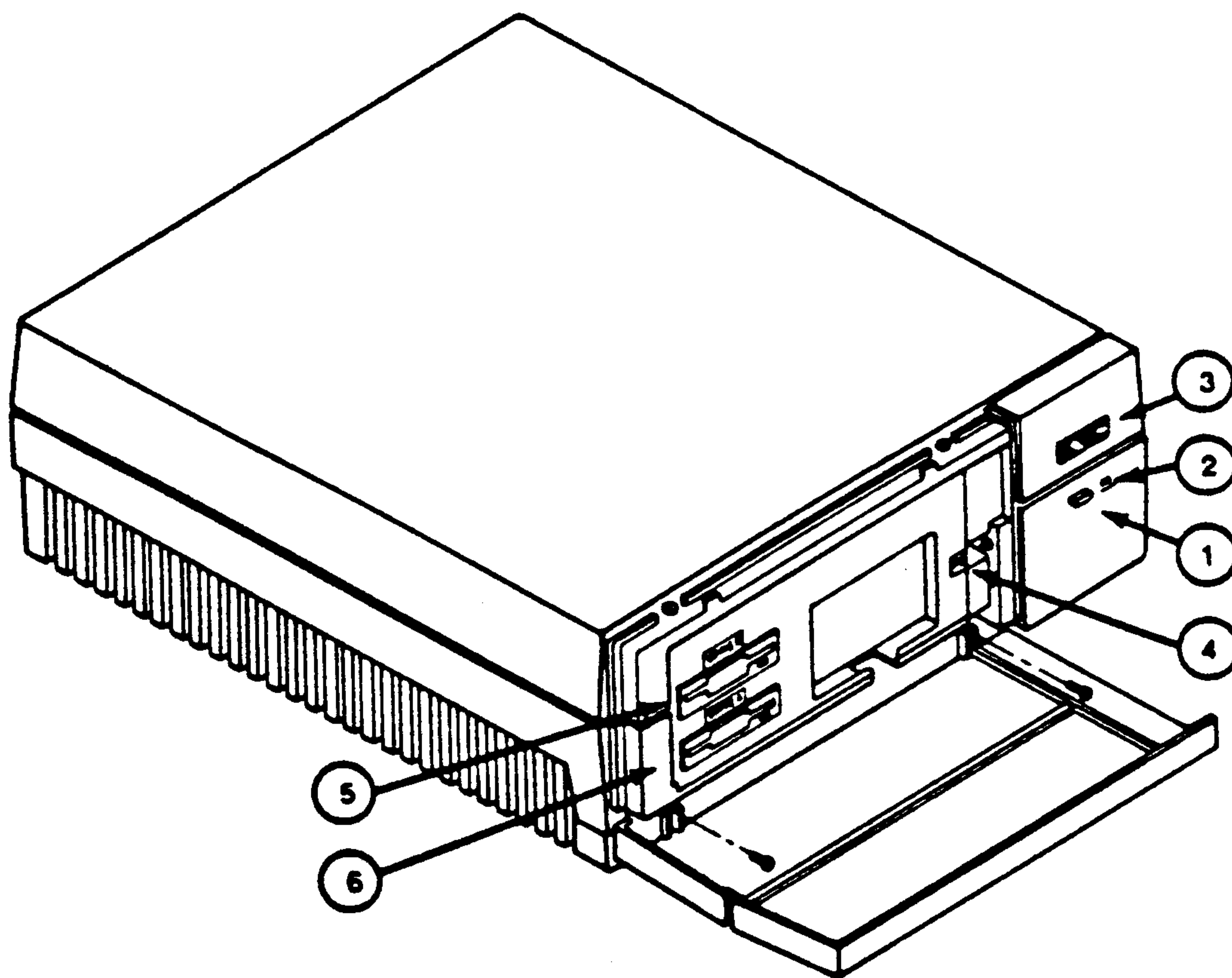

Figure 3-19. 1374 Model 5XR Operator Controls

1. **Power-On Switch:** Press the power-on switch to power the control unit on. Press the power switch again to switch control unit power off. When powered on, the control unit is initialized and conducts self-tests.
2. **Power Indicator:** This green LED lights when power is turned on and the unit is operational.
3. **Four-Digit Alphanumeric Indicator:** This 4-digit LED (e.g., "P080," "P081") indicates progress of power-on tests and system operation. During normal operation the indicators are blank. During power up and IML, the indicators momentarily display test information. If this information remains in the indicators or appears during operation, refer to the *1374 Troubleshooting Guide*.
4. **Initial Microprogram Load (IML) Switch:** This switch initiates power-on reset that includes initialization of hardware, power-on diagnostics, and program load self-testing.
- 5/6. **Diskette Drive:** The Diskette Drive Access Indicator lights when information is read from or written to a diskette.

SITE PLANNING AND MANAGEMENT

The power connector, voltage selector, coax and A/A ports, and host adapter are located on the rear panel.

BACK PANEL

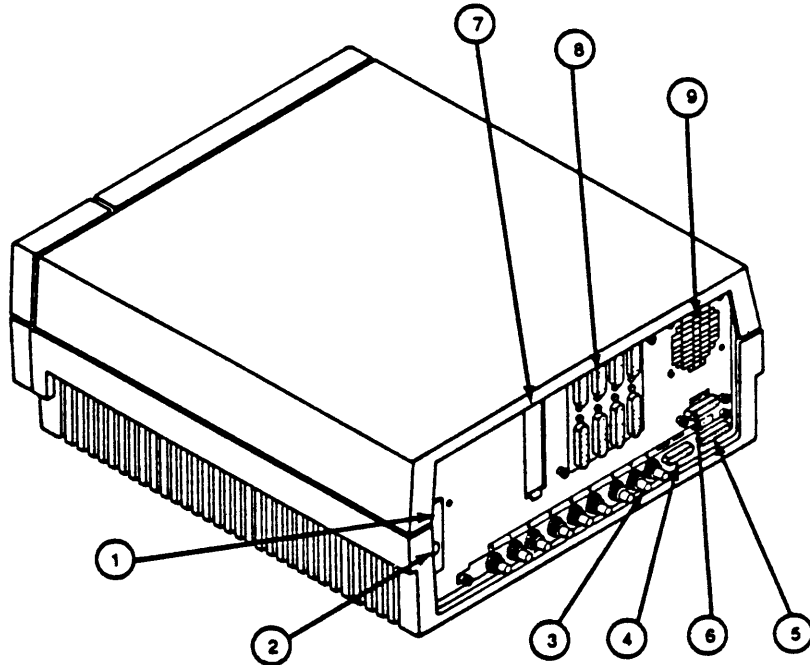

Figure 3-20. Typical 1374 Model 5XR Back Panel

1. **Power Cord Connector**
2. **Voltage Selection Switch**
3. **Coax/Twisted-Pair Cable port**
4. **Maintenance Port**
5. **Host 1**
6. **Host 2**
7. **General-Purpose Option Slot**
8. **Asynchronous Adapter Connector Panel (models 51R/52R)**
9. **Cooling Fan**

CLEARANCES

5XR series control units require a 3-inch left- and right-side and 6-inch rear ventilation and maintenance clearance. Rear clearance must be maintained during normal operations to ensure adequate cooling and space for coax cable attachment.

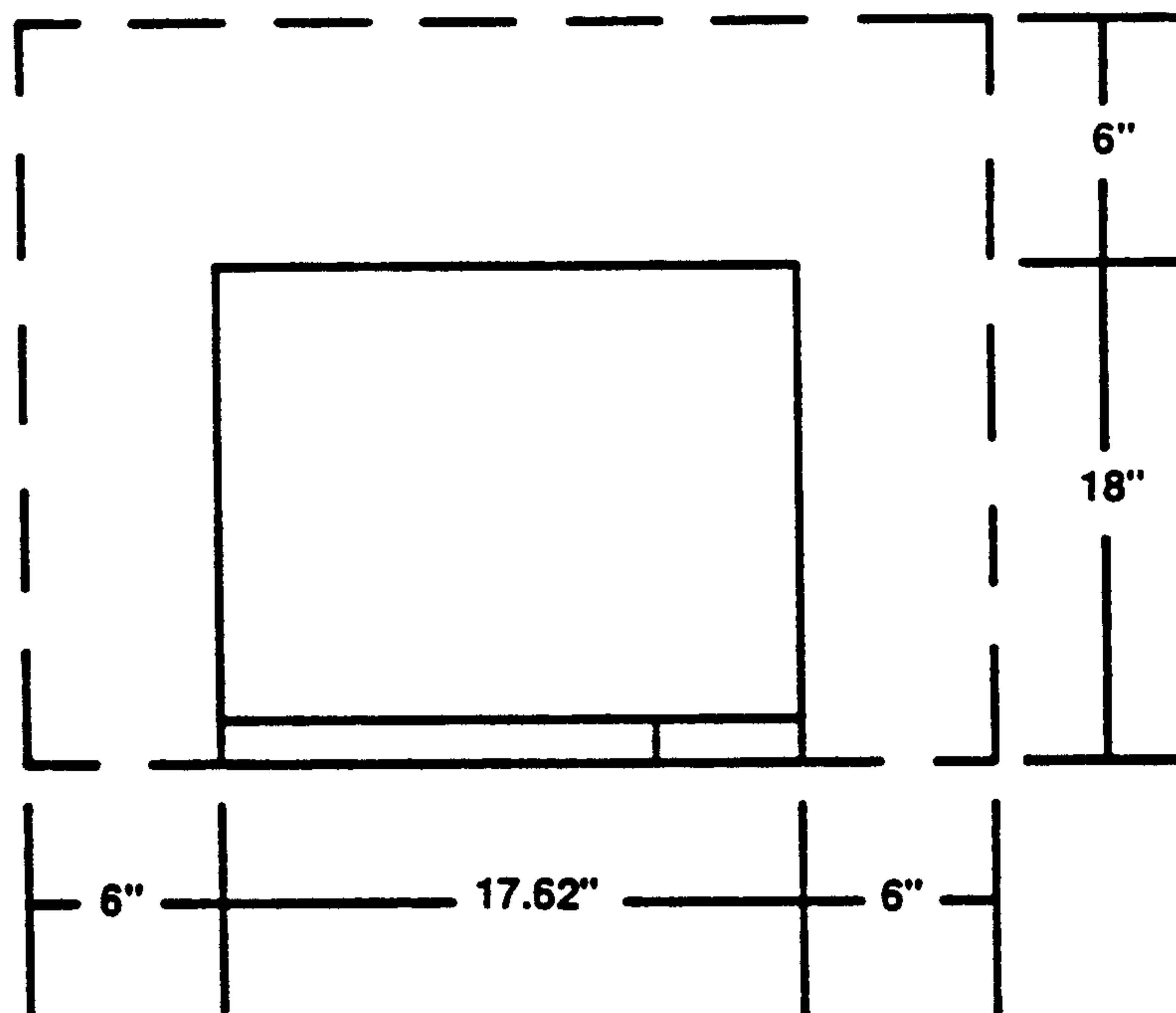

Figure 3-21. 1374 Model 5XR Clearances (Top-Down View)

COOLING

Cooling air is drawn from the right side of the unit through the chassis and then exhausted by a fan through the upper left corner of the rear panel.

ACOUSTIC NOISE

All models produce very limited disk drive and fan noise. The disk drives are accessed only during power up or IML (Initial Microprogram Load). The noise level for each model is less than 55 dB.

ELECTRICAL REQUIREMENTS

POWER PLUGS AND RECEPTACLES

Domestic 120 VAC control units have nonlocking 125V/15A plugs (5-15P, NEMA) and use matching receptacles (5-15R, NEMA).

International 220 VAC control units have nonlocking 250V/15A plugs determined by the country type: Continental Europe, United Kingdom, or Australia.

SITE PLANNING AND MANAGEMENT

Ensure that the correct receptacle is available for the power plug ordered for your control unit.

POWER CORDS

For units set at 120V: Use a UL Listed type SJT cord, 3-conductor, rated 10A, 125V, not to exceed 15 feet in length (7.5-foot cord is shipped with the control unit).

For units set at 220V (domestic): Use a UL Listed type SJT cord, 3-conductor, rated 6A, 250V, not to exceed 15 feet in length.

For units set at 220V (for use outside of U.S.): Use a 3-conductor cord, rated 6A, 250V with appropriate safety approvals for the country in which the equipment is to be installed.

The use of extension cords is not recommended.

HOST SYSTEM REQUIREMENTS

The host system requires specific preparation to support 5XR series control units. If an IBM 3174 or equivalent control unit is being replaced with a 5XR control unit, these host requirements have been completed. If host preparation is required, assign a person familiar with the hardware/software configuration to plan and implement the following items:

1. System generation of terminal addresses

Update the I/O definition of the host system to reflect the addition of new terminals to the system. If a 5XR series control unit is replacing an existing control unit and no other changes are being made, changes are probably not required. If this is a new control unit installation, or if other changes are made (such as attaching A/A devices), a new I/O definition is required. Implement changes prior to installation.

2. **Models 51R/52R:** Control unit address

Non-SNA Operation: The unit requires an 8-bit address, defined to models 51R and 52R as two remote configuration hexadecimal digits. Addresses are determined by the type of operation (SDLC or BSC).

Any *valid* address except FF hex may be used as the first terminal address on the control unit. Assign contiguous terminal addresses, including the beginning address, for the models' devices.

SNA Operation: Only a control unit address is required since terminal addresses are included in the SNA data stream. *Do not use FF hex.*

3. Model 53R: Control unit address

The LAN address is a 6-byte, 12-digit address. *Do not use FF hex.*

SETUP AND INSTALLATION PROCEDURES

The control unit arrives with standard (or specified) cables and documentation. After unpacking the control unit, complete the setup instructions required to install the control unit, attach the device cables, and begin configuration procedures.

Unpacking instructions are included in Appendix D. These instructions are also be attached to the outside of the shipping container. Setup instructions are packed inside the shipping container.

HOST ATTACHMENT

The customer is responsible for the installation of required modems and communication line facilities. These components must be compatible with the selected operating mode.

COMMUNICATION ATTACHMENT

The following items should be considered: line speed, full-duplex/half-duplex, and Non-Return to Zero (NRZ)/Non-Return to Zero Inverted (NRZI). Specialists for the communication facility and control unit can assist in planning for these requirements.

Table 2-1 in this manual lists remote configurations for models 51R, and 52R.

NOTE: Model 51R is compatible with IBM's implementation of combined RS 232C and V.35 (EIA/V.35) signals. For proper operation, use the communications cable supplied with the control unit.

MODEM SUPPORT

Modems are not supplied with the control units. Any modem that meets 3270 specifications may be used. The customer is responsible for maintaining the modems and all attached communications lines.

A standard 20-foot communications cable is supplied with these models for modem attachment. Alternative lengths of 10, 30, and 40 feet may be specified. Only these modem cables should be attached to the control unit. Do not use a cable longer than 40 feet.

Instructions detailing how to attach the modem cable to the control unit are included in the Setup Instructions.

SITE PLANNING AND MANAGEMENT

COAX DEVICE ATTACHMENT

Coax displays and printers are attached to 1374 control units with dual-purpose BNC connectors that support standard coaxial connections or connections to the IBM cabling system. Any supported device that has been connected to an IBM 3174 or compatible control unit may be attached to a 5XR control unit.

COAX CABLE REQUIREMENTS

The required device cable is commercially designated as RG 62A/U. Local regulations may require a special type of outside covering such as outdoor/weather-proof, fire-retardant, and/or plenum rated fire-/smoke-retardant. For additional information, refer to the installation manuals for the attached devices or to related IBM documentation.

Devices may be installed up to 4,920 feet (1,500 meters) from the control unit. The customer is responsible for procuring, installing, and maintaining coaxial cables and connectors.

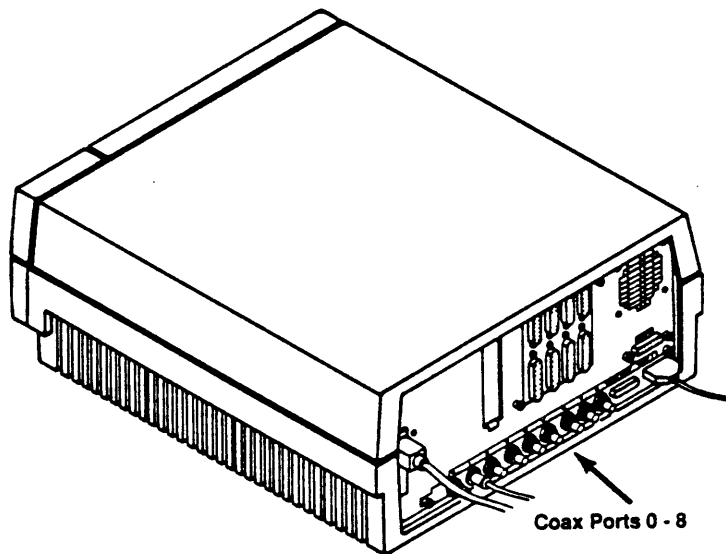

Figure 3-22. Typical 1374 Model 5XR Coax Device Attachment

COAX MULTIPLEXER

The coax multiplexer attaches to 5XR series control units via coax cable, telephone twisted-pair cable, or IBM Cabling System types 1, 3, and 9. The Dual-Purpose Connector (DPC) on the rear of the multiplexer eliminates the need to use baluns, which balance the signals for transmission from terminals and peripherals.

The multiplexer can be attached to any of the ports on the control unit.

DYNAMIC MULTIPLEXER COAX PORT MAPPING

Dynamic Multiplexer Coax Port Mapping allows any port to have either a direct-attached device or from two to eight multiplexed devices. The total number of logical ports for the controller is limited to 16. The LCP Configure Multiplexer command (CW) is used to define the logical ports associated with each physical coax connector. LCP commands continue to use the logical port number as an index into device control blocks and configuration tables.

In the next figure, the first column of the screen contains the physical port numbers that correspond to the connectors on the controller. These numbers are always displayed sequentially. The number of physical ports displayed is the maximum number connected to the controller, even if there is not a coax extender present on the system. The second column is a list of all logical ports associated with a physical port. The first logical port in the list can either be directly attached, or connected to address 0 on a multiplexer. Subsequent logical ports on the list are attached to multiplexer at addresses 1, 2, and so on.

A logical port can appear twice on the LCP CW screen, but it can only appear once as the first logical port in a list. When the controller detects a valid device in either of the two locations, the other location for that logical port is disabled. It is possible that there may be physical ports without any logical ports and, conversely, that there are logical ports that are not assigned to a physical port.

```
====>C CW
Modify panel and ENTER, or use PF3 to exit
```

<u>Physical Port</u>	<u>Logical Port(s)</u>
0	0 1 2 3 4 5 6 7
1	1
2	2
3	3
4	4
5	5
6	6
7	7
8	8 9 10 11 12 13 14 15

Figure 3-23. Default Configuration

SITE PLANNING AND MANAGEMENT

The next two figures show examples of two possible ways that the logical ports can be configured.

```
====> CW
Modify panel and ENTER, or use PF3 to exit

-----

Physical
Port      Logical Port(s)
0         0 1 2 3 4 5 6 7
1         8 9 10 11 12 13 14 15
2         2
3         3
4         4
5         5
6         6
7         7
8
```

Figure 3-24. Sample Configuration Ports 0 and 1

```
====>C CW
Modify panel and ENTER, or use PF3 to exit

-----

Physical
Port      Logical Port(s)
0         0
1         1
2         2
3         3
4         4
5         0 1 2 3 4 5 6 7
6         8 9 10 11 12 13 14 15
7
8
```

Figure 3-25. Sample Configuration Ports 5 and 6

1374 DISKETTES

Control unit operational and diagnostic software, stored on 3.5-inch diskettes, is loaded from the disk drive. The diskette label must be facing up when the diskette is inserted into the disk drive. The system diskette should remain in the drive at all times. Disk drive access occurs only after power-on tests have been successfully completed and the system is initialized.

STANDARD DISKETTES

5XR series control units include the following standard diskettes:

- System: contains network architecture and system protocol
- Utility: provides specialized offline utility programs
- Standard Language: contains non-RPQ languages

The next table shows the diskettes required for each 1374 model.

Diskette Type	51R	52R	53R
System			
SNA/SDLC	C	C	
BSC	X		
X.25	C	C	
SNA, LAN Gateway	C	C	
LAN Interface			X
Utility			
	C	C	C
Standard Language			
	C	C	C

X = One diskette per model type
 C = Common to models indicated

The Dual SNA/SDLC Host option is supported on the SDLC System Diskette.

Table 3-8. Standard Diskettes – 5XR Series

SITE PLANNING AND MANAGEMENT

SPECIAL SYSTEM DISKETTES

The Dual SNA/SDLC Host and Token-Ring Gateway options require a special system diskette. The diskette is supplied with the option.

<u>Diskette Type</u>	<u>51R</u>	<u>52R</u>	<u>53R</u>
Dual SNA/SDLC Host and TR Gateway	C	C	

Table 3-9. Special System Diskettes – 5XR Series

OPTIONAL DISKETTES

The following diskettes are optionally available for 5XR series control units:

<u>Diskette Type</u>	<u>51R</u>	<u>52R</u>	<u>53R</u>
ACS	C	C	C
Diagnostics	C	C	C
Dump	C	C	C
RPQ Language	C	C	C

Table 3-10. Optional Diskettes – 5XR Series

ACS Diskettes (2): In addition to the functions listed, the first diskette contains the Asynchronous Communications Support functions used to configure the control unit for Asynchronous/ASCII (A/A) terminal, printer, and host support. The other diskette, which runs on a PC, contains the PC emulation code. The ACS option requires an optional second disk drive.

Diagnostics Diskette: contains the 1374 diagnostics software.

Dump Diskette: contains the software and the space necessary to perform a memory dump of the control unit memory.

RPQ Language Diskette: contains RPQ languages.

1374 MODEL 61R

INSTALLATION REQUIREMENTS

The following section describes specific physical, environmental, and power requirements to consider before installing the control unit.

PHYSICAL DESCRIPTION

This tabletop controller normally operates in office environments. The next figure shows enclosure dimensions, diskette drive, front power switch, and LED power and status indicator lights.

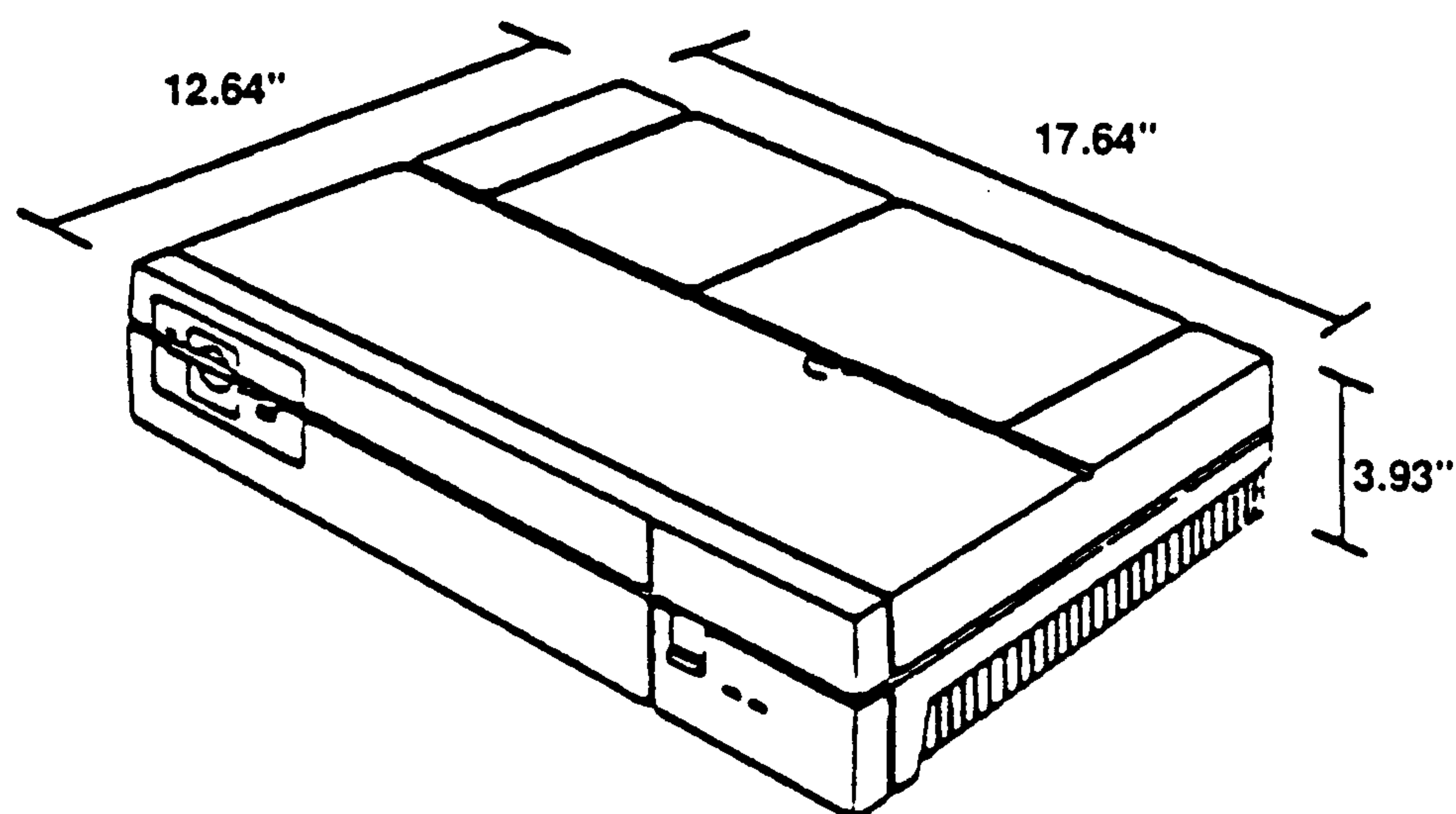

Figure 3-26. 1374 Model 61R

Device, host, maintenance, and power connectors are at the rear. The next figure shows the rear panel of the unit. During normal operation the top cover and backplate should not be removed.

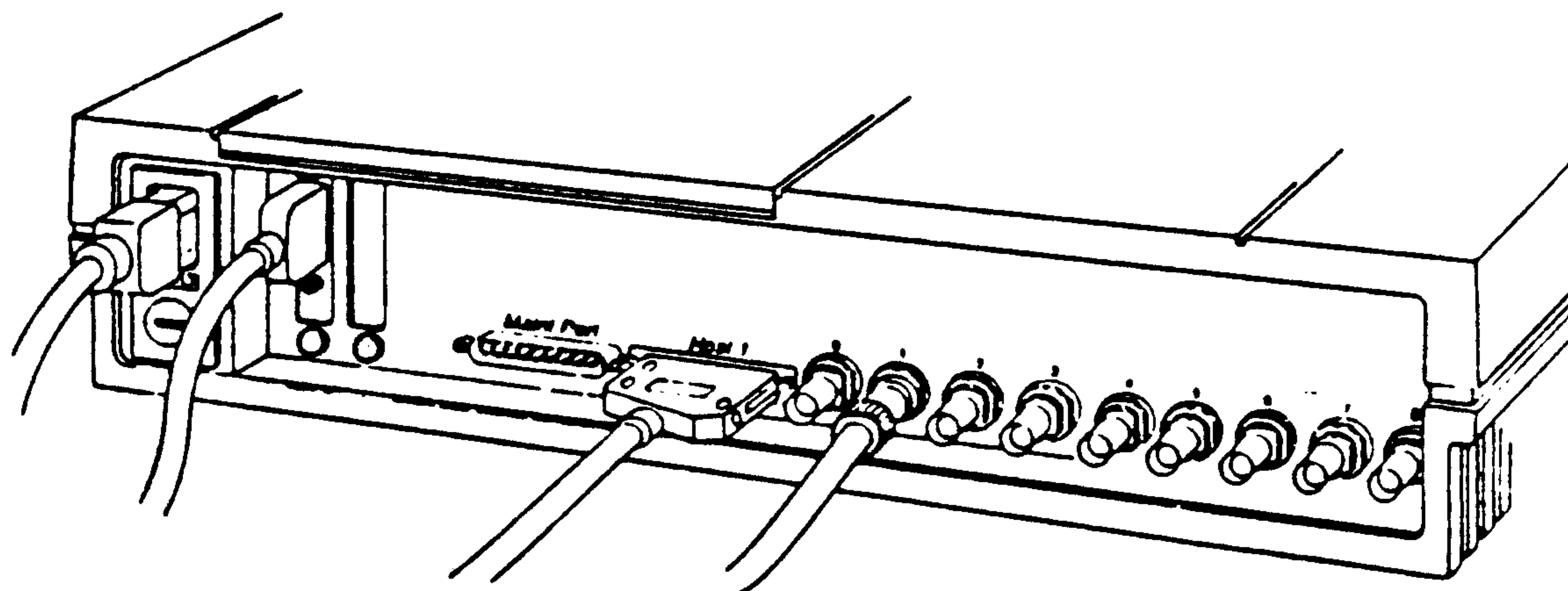

Figure 3-27. 1374 Model 61R Rear Panel

SITE PLANNING AND MANAGEMENT

The diskette storage area and option slot filler panels are housed under the control unit access door.

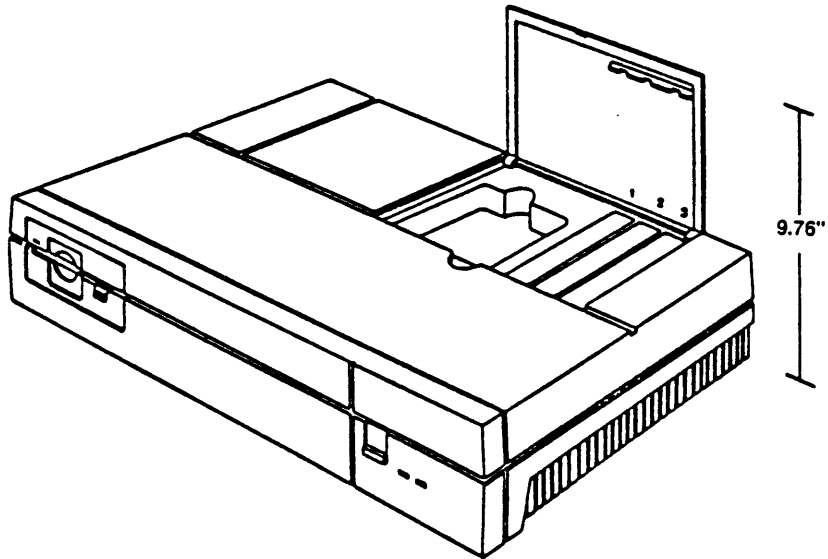

Figure 3-28. 1374 Model 61R Top View

CLEARANCES

The 61R control unit is a tabletop unit and can be easily moved for maintenance. It requires a rear clearance for cables and a side clearance for air intake and cooling. The clearance requirement is six inches in the rear and three inches on either side of the control unit. To maintain access to the diskette storage area and PCB slots, do not place materials on top of the unit.

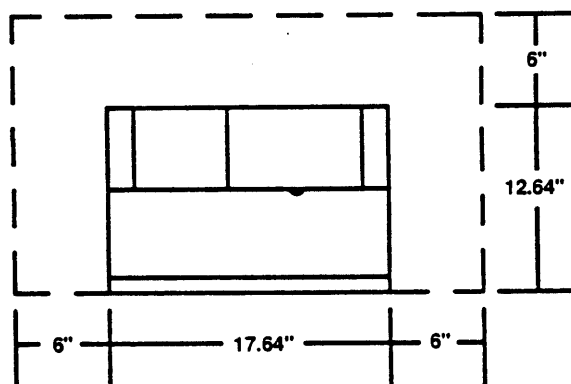

Figure 3-29. 1374 Model 61R Clearance Requirements

SITE PLANNING AND MANAGEMENT

COOLING

Cooling air, drawn from the right side of these units by a single fan, passes through the PCB assemblies and power supply, and exits the left side. To keep the cooling vents free of obstruction, do not place papers under or around the control unit.

ACOUSTIC NOISE

This model produces very limited disk drive and fan noise. The disk drive is accessed during power-up or IML (Initial Microprogram Load), DSL terminal microcode loading, and during periodic exercise by the software. The noise level for the model is less than 55 dB.

ELECTRICAL REQUIREMENTS

POWER PLUGS AND RECEPTACLES

Domestic 120 VAC control units have nonlocking 125V/15A plugs (5-15P, NEMA) and use matching receptacles (5-15R, NEMA).

International 220 VAC control units have nonlocking 250V/15A plugs determined by the country type: Continental Europe, United Kingdom, or Australia.

Ensure that the correct receptacle is available for the power plug ordered for your control unit.

POWER CORDS

For units set at 120V: Use a UL Listed type SJT cord, 3-conductor, rated 10A, 125V, not to exceed 15 feet in length (7.5-foot cord is shipped with the control unit).

For units set at 220V (domestic): Use a UL Listed type SJT cord, 3-conductor, rated 6A, 250V, not to exceed 15 feet in length.

For units set at 220V (for use outside the U.S.): Use a 3-conductor cord, rated 6A, 250V with appropriate safety approvals for the country in which the equipment is to be installed.

The use of extension cords is not recommended.

SITE PLANNING AND MANAGEMENT

HOST SYSTEM REQUIREMENTS

The host system requires specific preparation to support the model 61R control unit. If an IBM 3174 or equivalent controller is being replaced with a model 61R, these host requirements have been completed. If host preparation is required, assign a person familiar with the hardware/software configuration to plan and implement the following items:

1. System Generation of terminal addresses

Update the I/O definition of the host system to reflect the addition of new terminals to the system. If a model 61R is replacing an existing controller and no other changes are being made, changes are probably not required. If this is a new controller installation, or if other changes are made, a new I/O definition is required. Coordinate any changes with the installation.

2. Controller address

Non-SNA Operation: The unit requires an 8-bit address, defined to the 61R control unit as two remote configuration hexadecimal digits. Addresses are determined by the type of operation (BSC).

Any *valid* address except FF hex may be used as the first terminal address on the controller. Assign contiguous terminal addresses, including the beginning address, for model 61R devices. The Configure Logical Units (CL) LCP command is used to configure host addresses.

SNA Operation: Only a controller address is required since terminal addresses are included in the SNA data stream. *Do not use FF hex.*

SETUP AND INSTALLATION PROCEDURES

The control unit arrives with standard (or specified) cables and documentation. After unpacking the machine, complete the setup instructions to physically install the control unit, attach device cables, and begin the configuration procedure.

Unpacking instructions are included in Appendix D. These instructions are also shown on the outside of the shipping container. Setup instructions are packed inside the container.

HOST ATTACHMENT

COMMUNICATION ATTACHMENT

Install the required modems and communication line facilities. These components must be compatible with the selected operating mode.

The following items should be considered: line speed, full-duplex/half-duplex, and Non-Return to Zero (NRZ)/Non-Return to Zero Inverted (NRZI). Specialists for the communication facility and control unit can assist in planning for these requirements.

Table 2-1 in this manual lists remote configurations for model 61R.

MODEM SUPPORT

Modems are not supplied with the control units. Any modem that meets 3274 specifications may be used.

A standard 20-foot communications cable is supplied with these remote models for modem attachment. Alternate lengths of 10, 30, and 40 feet may be specified. Only these modem cables should be attached to the control unit. Do not use a cable longer than 40 feet.

Instructions detailing how to attach the modem cable to the control unit are included in the Setup Instructions. The next figure shows the communications cable connected to Host 1. (Maint Port is used for diagnostic testing and may be connected to a local terminal, or a modem for remote testing.)

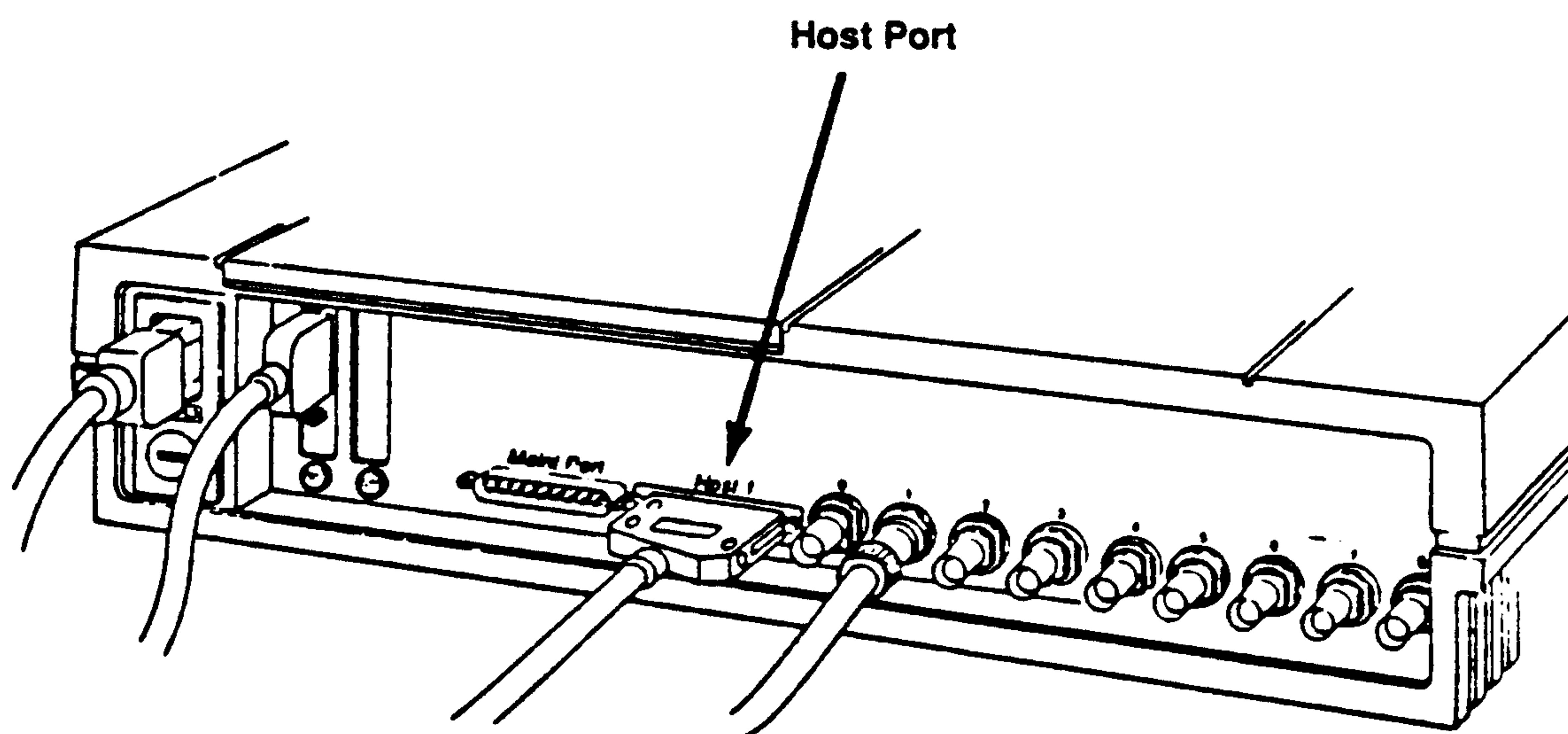

Figure 3-30. Host Cable Setup – Model 61R

SITE PLANNING AND MANAGEMENT

DEVICE ATTACHMENT

Category A displays and coax printers attach to control units via standard coaxial cable with BNC connectors. Any supported device that has been connected to an IBM 3174 or compatible control unit may be attached to the control unit.

Cabling to terminals is via direct attachment to the IBM cabling system when using 61R control units with IBM data-grade cabling. A balun cable assembly is not required at the control unit end of the cable.

The cables that connect Asynchronous/ASCII (A/A) displays and printers to 61R control units have special wiring requirements, and must meet specific requirements. Refer to the *1374 ACS Operations Manual* for detailed information.

COAX CABLE REQUIREMENTS

The required device cable is commercially designated as RG 62A/U. Local regulations may require a special type of outside covering such as outdoor-/weather-proof, fire-retardant, and/or plenum rated fire-/smoke-retardant. For additional information, refer to the installation manuals for the attached devices or to related IBM documentation.

Devices may be installed up to 4,920 feet (1,500 meters) from the control unit. Coaxial cables and connectors are not supplied with the control unit.

Category A device cables are attached to rear connectors, as shown in next.

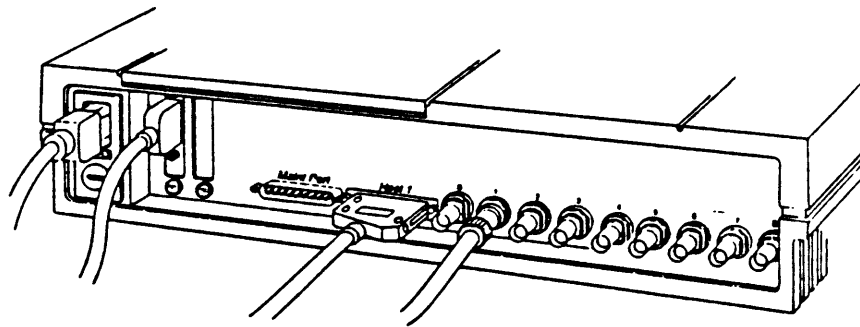

Figure 3-31. Model 61R Coax and A/A Device Attachment

SITE PLANNING AND MANAGEMENT

ASYNCHRONOUS/ASCII CABLE REQUIREMENTS

Asynchronous/ASCII (A/A) devices attached to the control unit via the Serial Port Option PCB have specific wiring requirements. Refer to the *1374 ACS Operations Manual* for detailed information on serial cable specifications. Use 24-gauge cable material with at least eight conductors. The maximum cable length, as specified by the RS 232C standard, is 50 feet. User-defined printers may require unique pin assignments.

Use a standard Centronics parallel interface cable to connect a parallel interface printer to the control unit via the Parallel Port Option PCB.

A/A device cables are attached to the serial port or the parallel port.

COAX MULTIPLEXER

The coax multiplexer attaches to 61R control unit via coax cable, telephone twisted-pair cable, or IBM cabling system types 1, 3, and 9. The Dual-Purpose Connector (DPC) on the rear of the multiplexer eliminates the need to use baluns, which balance the signals for transmission from terminals and peripherals.

The multiplexer can be attached to any of the ports on the control unit.

DYNAMIC MULTIPLEXER COAX PORT MAPPING

Dynamic Multiplexer Coax Port Mapping allows any port to have either a direct-attached device or from two to eight multiplexed devices. The total number of logical ports for the controller is limited to 16. A new LCP Configure Multiplexer command (CW) is used to define the logical ports associated with each physical coax connector. LCP commands continue to use the logical port number as an index into device control blocks and configuration tables.

In the next figure, the first column of the screen contains the physical port numbers that correspond to the connectors on the controller. These numbers are always displayed sequentially. The number of physical ports displayed is the maximum number connected to the controller, even if there is not a coax extender present on the system. The second column is a list of all logical ports associated with a physical port. The first logical port in the list can either be directly attached, or connected to address 0 on a multiplexer. Subsequent logical ports on the list are attached to multiplexer at addresses 1, 2, and so on.

A logical port can appear twice on the LCP CW screen, but it can only appear once as the first logical port in a list. When the controller detects a valid device in either of the two locations, the other location for that logical port is disabled. It is possible that there may be physical ports without any logical ports and, conversely, that there are logical ports that are not assigned to a physical port.

SITE PLANNING AND MANAGEMENT

```
====>C CW  
Modify panel and ENTER, or use PF3 to exit
```

<u>Physical Port</u>	<u>Logical Port(s)</u>
0	0 1 2 3 4 5 6 7
1	1
2	2
3	3
4	4
5	5
6	6
7	7
8	8 9 10 11 12 13 14 15

Figure 3-32. Default Configuration

The next two figures show examples of two possible ways that the logical ports can be configured.

```
====> CW  
Modify panel and ENTER, or use PF3 to exit
```

<u>Physical Port</u>	<u>Logical Port(s)</u>
0	0 1 2 3 4 5 6 7
1	8 9 10 11 12 13 14 15
2	2
3	3
4	4
5	5
6	6
7	7
8	

Figure 3-33. Sample Configuration Ports 0 and 1

```
====>C CW  
Modify panel and ENTER, or use PF3 to exit
```

<u>Physical Port</u>	<u>Logical Port(s)</u>
0	0
1	1
2	2
3	3
4	4
5	0 1 2 3 4 5 6 7
6	8 9 10 11 12 13 14 15
7	
8	

Figure 3-34. Sample Configuration Ports 5 and 6

1374 DISKETTES

Control unit operational and diagnostic software, stored on 3.5-inch diskettes, is loaded from the disk drive. The diskette label must be facing up when the diskette is inserted into the disk drive. The system diskette should remain in the drive at all times. Disk drive access occurs only after power-on tests have been successfully completed and the system is initialized.

STANDARD DISKETTES

The model 61R control unit includes the following standard diskettes:

- System: contains network architecture and system protocol
- Utility: provides specialized offline utility programs
- Standard Language: contains non-RPQ languages

The next table shows the diskettes required for each model.

SITE PLANNING AND MANAGEMENT

Diskette Type

System
SNA/SDLC
BSC
X.25

Utility

Standard Language

The IBM Dual SDLC Host option is supported on the SDLC System Diskette.

Table 3-11. Standard Diskettes – 61R

OPTIONAL DISKETTES

The following diskettes are optionally available for 61R control units:

Diskette Type

ACS

Diagnostics

Dump

RPQ Language

Table 3-12. Optional Diskettes – 61R

ACS Diskettes (2): In addition to the functions listed, the first diskette contains the Asynchronous Communications Support functions used to configure the control unit for Asynchronous/ASCII (A/A) terminal, printer, and host support. The other diskette, which runs on a PC, contains the PC emulation code.

Diagnostics Diskette: contains the 1374 diagnostics software.

Dump Diskette: contains the software and the space necessary to perform a memory dump of the control unit memory.

RPQ Language: contains the RPQ languages.

1374 MODEL 71R/72R/73R

INSTALLATION REQUIREMENTS

The following section describes specific physical, environmental, and power requirements to consider before installing the control unit.

PHYSICAL DESCRIPTION

These tabletop controllers normally operate in office environments. The next figure shows enclosure dimensions, diskette drive, front power switch, and LED power and status indicator lights.

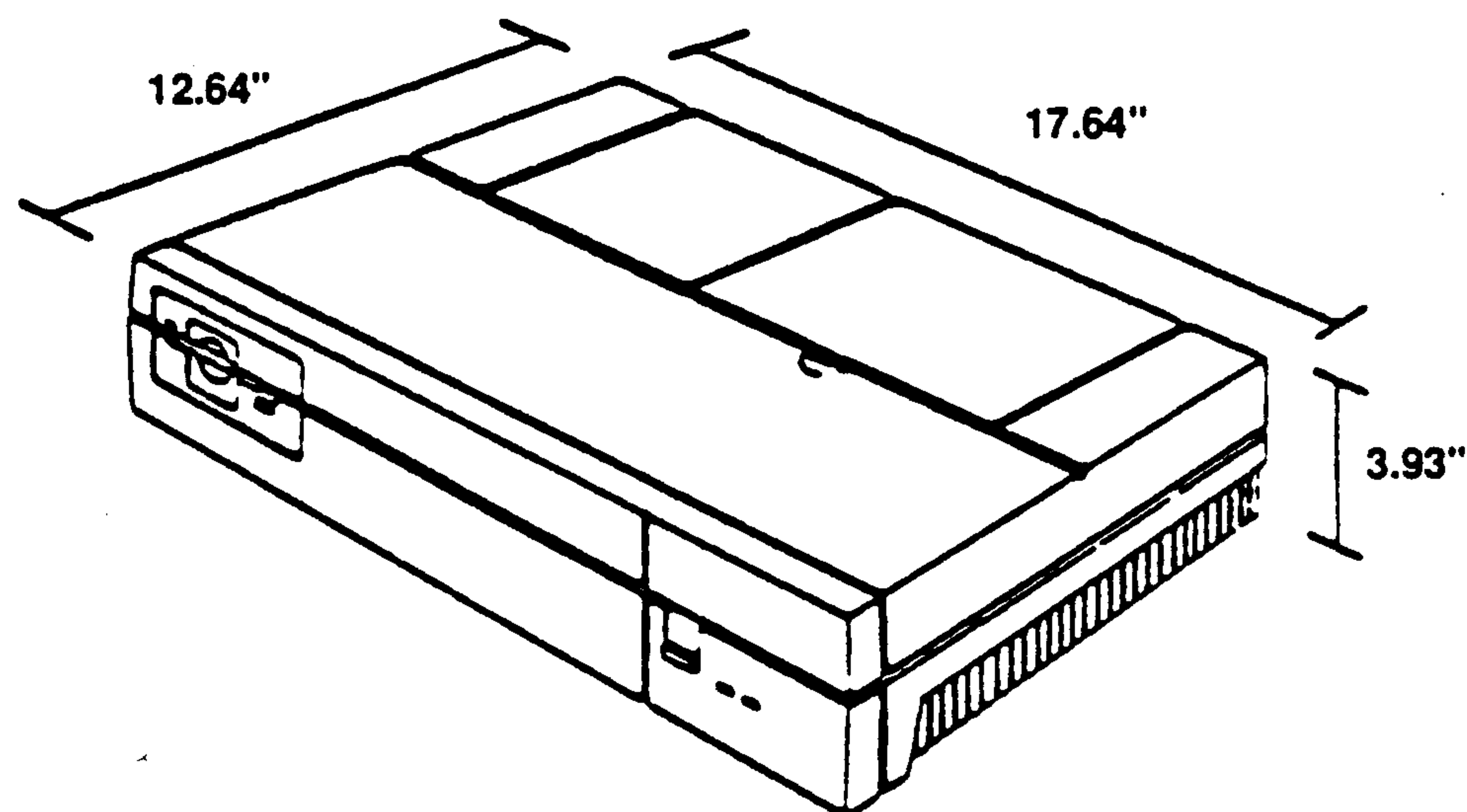

Figure 3-35. 1374 Model 7XR

Device, modem, diagnostic, and power connectors are at the rear. The next figure shows the rear panel of the unit. During normal operation the top cover and backplate should not be removed.

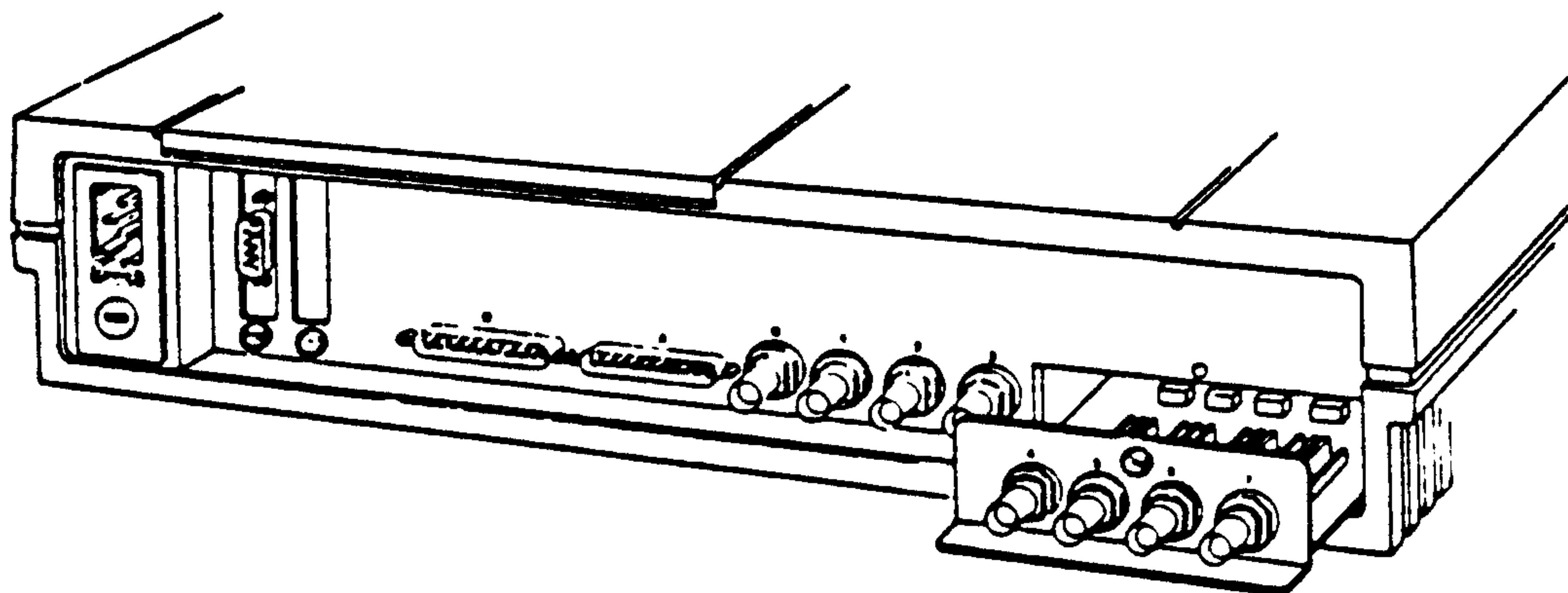

Figure 3-36. Typical 1374 Model 7XR Rear Panel

SITE PLANNING AND MANAGEMENT

NOTE: Port A is a 25-pin D-sub connector on model 71R, a 15-pin D-sub connector on model 72R, and a 9-pin D-sub connector on model 73R.

The diskette storage area and option slot filler panels are housed under the control unit access door.

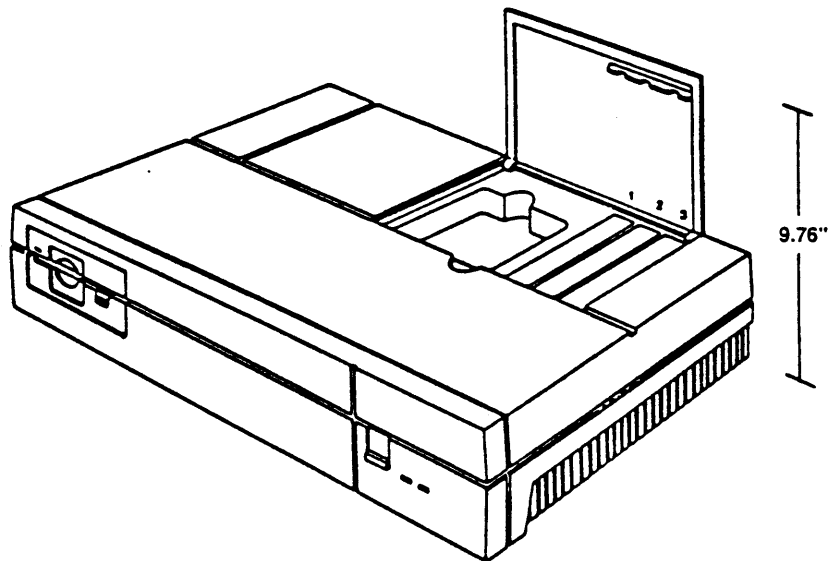

Figure 3-37. 1374 Model 7XR Top View

CLEARANCES

7XR control units are tabletop units and can be easily moved for maintenance. They require a rear clearance for cables and a side clearance for air intake and cooling. The clearance requirement is six inches in the rear and three inches on either side of the control unit. To maintain access to the diskette storage area and PCB slots, do not place materials on top of the unit.

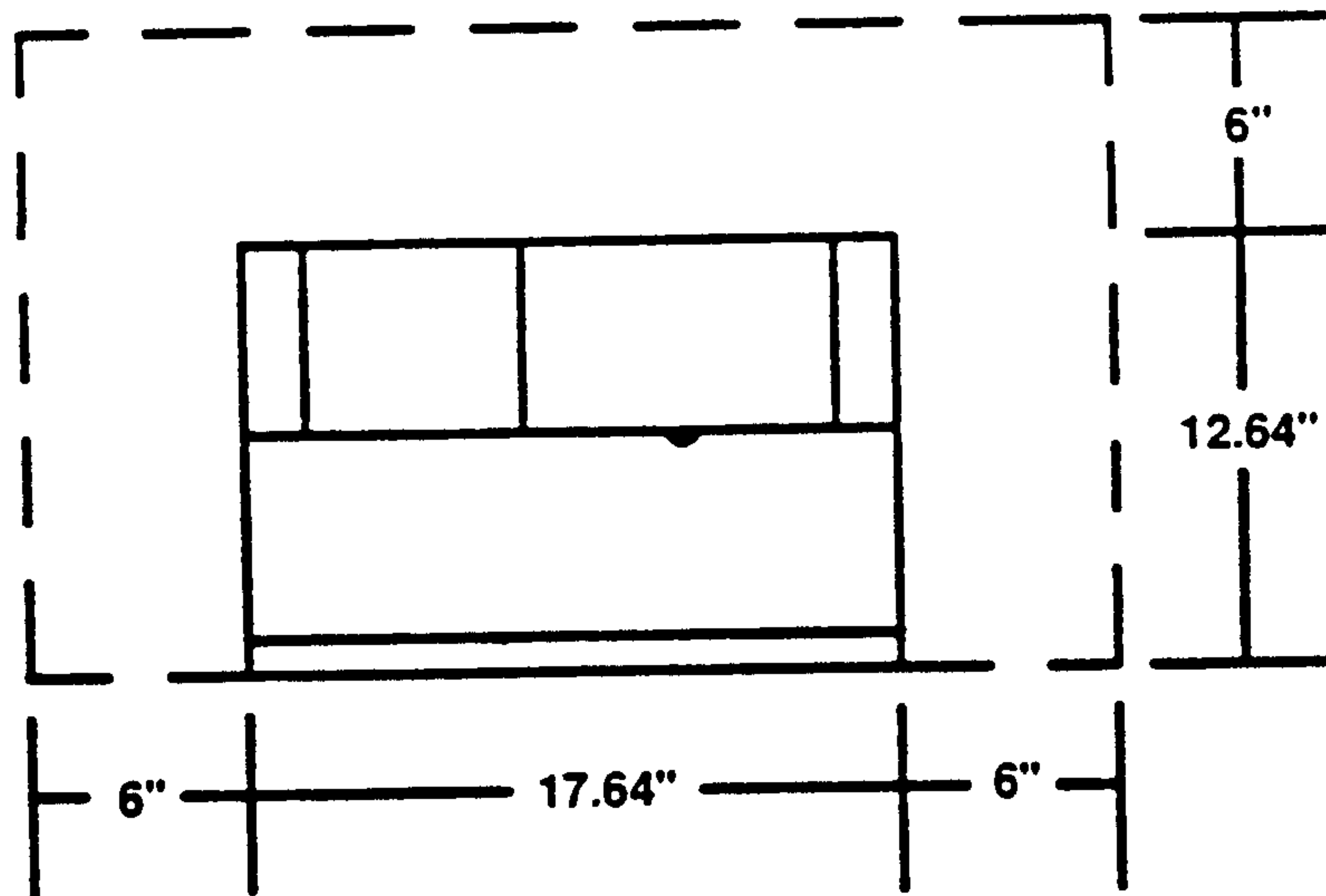

Figure 3-38. 1374 Model 7XR Clearance Requirements

COOLING

Cooling air, drawn from the right side of these units by a single fan, passes through the PCB assemblies and power supply, and exits the left side. To keep the cooling vents free of obstruction, do not place papers under or around the control unit.

ACOUSTIC NOISE

All models produce very limited disk drive and fan noise. The disk drive is accessed during powerup or IML (Initial Microprogram Load), DSL terminal microcode loading, and during periodic exercise by the software. The noise level for each model is less than 55 dB.

ELECTRICAL REQUIREMENTS

POWER PLUGS AND RECEPTACLES

Domestic 120 VAC control units have nonlocking 125V/15A plugs (5-15P, NEMA) and use matching receptacles (5-15R, NEMA).

International 220 VAC control units have nonlocking 250V/15A plugs determined by the country type: Continental Europe, United Kingdom, or Australia.

Ensure that the correct receptacle is available for the power plug ordered for your control unit.

POWER CORDS

For units set at 120V: Use a UL Listed type SJT cord, 3-conductor, rated 10A, 125V, not to exceed 15 feet in length (7.5-foot cord is shipped with the control unit).

SITE PLANNING AND MANAGEMENT

For units set at 220V (domestic): Use a UL Listed type SJT cord, 3-conductor, rated 6A, 250V, not to exceed 15 feet in length.

For units set at 220V (for use outside the U.S.): Use a 3-conductor cord, rated 6A, 250V with appropriate safety approvals for the country in which the equipment is to be installed.

The use of extension cords is not recommended.

HOST SYSTEM REQUIREMENTS

The host system requires specific preparation to support models 7XR series control units. If an IBM 3174 or equivalent controller is being replaced with a model 71R or 72R, these host requirements have been completed. If host preparation is required, assign a person familiar with the hardware/software configuration to plan and implement the following items:

1. System Generation of terminal addresses

Update the I/O definition of the host system to reflect the addition of new terminals to the system. If a model 71R or 72R is replacing an existing controller and no other changes are being made, changes are probably not required. If this is a new controller installation, or if other changes are made, a new I/O definition is required. Coordinate any changes with the installation.

2. Controller address

Non-SNA Operation: The unit requires an 8-bit address, defined to the 7XR control unit as two remote configuration hexadecimal digits. Addresses are determined by the type of operation (BSC).

Any *valid* address except FF hex may be used as the first terminal address on the controller. Assign contiguous terminal addresses, including the beginning address, for models 71R, 72R, and 73R devices. The Configure Logical Units (CL) LCP command is used to configure host addresses.

SNA Operation: Only a controller address is required since terminal addresses are included in the SNA data stream. *Do not use FF hex.*

SETUP AND INSTALLATION PROCEDURES

The control units arrive with standard (or specified) cables and documentation. After unpacking the machine, complete the setup instructions to physically install the control unit, attach device cables, and begin the configuration procedure.

Unpacking instructions are included in Appendix D. These instructions are also shown on the outside of the shipping container. Setup instructions are packed inside the container.

HOST ATTACHMENT

COMMUNICATION ATTACHMENT

Install the required modems and communication line facilities. These components must be compatible with the selected operating mode.

The following items should be considered: line speed, full-duplex/half-duplex, and Non-Return to Zero (NRZ)/Non-Return to Zero Inverted (NRZI). Specialists for the communication facility and control unit can assist in planning for these requirements.

Table 2-1 in this manual lists remote configurations for models 71R and 72R.

MODEM SUPPORT

Modems are not supplied with the control units. Any modem that meets 3174 specifications may be used.

A standard 20-foot communications cable is supplied with these remote models for modem attachment. Alternative lengths of 10, 30, and 40 feet may be specified. Only these modem cables should be attached to the control unit. Do not use a cable longer than 40 feet.

Instructions detailing how to attach the modem cable to the control unit are included in the Setup Instructions. The next figure shows the communications cable connected to port A on models 71R and 72R. (Port B is used for diagnostic testing and may be connected to a local terminal, or a modem for remote testing.)

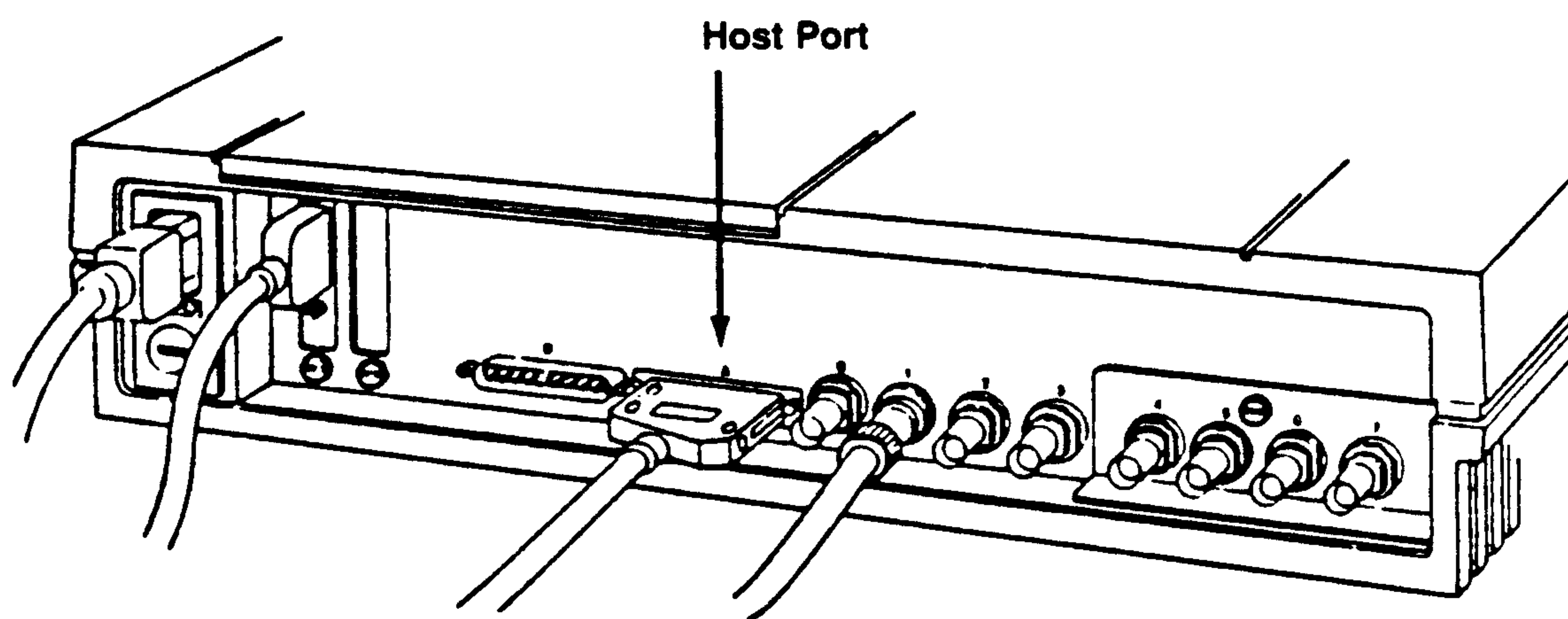

Figure 3-39. Host Cable Setup – Models 71R and 72R

SITE PLANNING AND MANAGEMENT

DEVICE ATTACHMENT

Category A displays and coax printers attach to Memorex Telex control units via standard coaxial cable with BNC connectors. Any supported device that has been connected to an IBM 3174 or compatible control unit may be attached to a 7XR control unit.

Cabling to terminals is via direct attachment to the IBM cabling system when using 7XR control units with IBM data-grade cabling. A balun cable assembly is not required at the control unit end of the cable.

The cables that connect Asynchronous/ASCII (A/A) displays and printers to 7XR series control units have special wiring requirements, and must meet specific requirements. Refer to the *1374 ACS Operations Manual* for detailed information.

COAX CABLE REQUIREMENTS

The required device cable is commercially designated as RG 62A/U. Local regulations may require a special type of outside covering such as outdoor-/weather-proof, fire-retardant, and/or plenum rated fire-/smoke-retardant. For additional information, refer to the installation manuals for the attached devices or to related IBM documentation.

Devices may be installed up to 4,920 feet (1,500 meters) from the control unit. Coaxial cables and connectors are not supplied with the control unit.

Category A device cables are attached to rear connectors, as shown next.

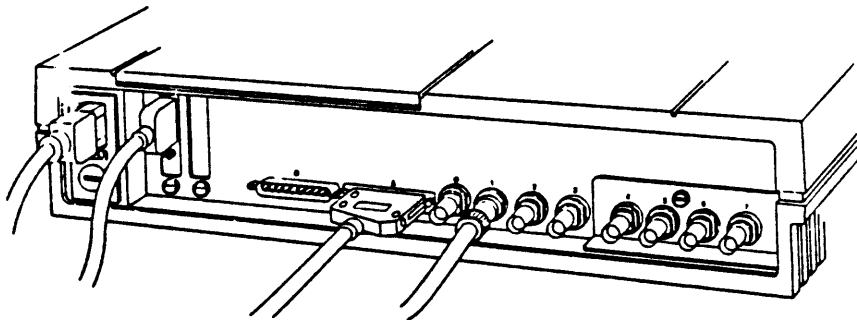

Figure 3-40. Model 7XR Coax and A/A Device Attachment

ASYNCHRONOUS/ASCII CABLE REQUIREMENTS

Asynchronous/ASCII (A/A) devices attached to the control unit via the Serial Port Option PCB have specific wiring requirements. Refer to the *1374 ACS Operations Manual* for detailed information on serial cable specifications. Use 24-gauge cable material with at least eight conductors. The maximum cable length, as specified by the RS 232C standard, is 50 feet. User-defined printers may require unique pin assignments.

Use a standard Centronics parallel interface cable to connect a parallel interface printer to the control unit via the Parallel Port Option PCB.

A/A device cables are attached to the serial port or the parallel port.

1374 DISKETTES

Control unit operational and diagnostic software, stored on 3.5-inch diskettes, is loaded from the disk drive. The diskette label must be facing up when the diskette is inserted into the disk drive. The system diskette should remain in the drive at all times. Disk drive access occurs only after power-on tests have been successfully completed and the system is initialized.

STANDARD DISKETTES

7XR series control units include the following standard diskettes:

- System: contains network architecture and system protocol
- Utility: provides specialized offline utility programs
- Standard Language: contains non-RPQ languages

The next table shows the diskettes required for each model.

Diskette Type	71R	72R	73R
System			
SNA/SDLC	C	C	
BSC	X		
X.25	C	C	
LAN Interface			X
Utility	C	C	C
Standard Language	C	C	C

X = One diskette per model type
 C = Common to models indicated

Table 3-13. Standard Diskettes – 7XR Series

SITE PLANNING AND MANAGEMENT

OPTIONAL DISKETTES

The following diskettes are optionally available for 7XR series control units:

<u>Diskette Type</u>	<u>71R</u>	<u>72R</u>	<u>73R</u>
ACS	C	C	C
Diagnostics	C	C	C
Dump	C	C	C
RPQ Language	C	C	C

Table 3-14. Optional Diskettes – 7XR Series

ACS Diskettes (2): In addition to the functions listed, the first diskette contains the Asynchronous Communications Support functions used to configure the control unit for Asynchronous/ASCII (A/A) terminal, printer, and host support. The other diskette, which runs on a PC, contains the PC emulation code.

Diagnostics Diskette: contains the 1374 diagnostics software.

Dump Diskette: contains the software and the space necessary to perform a memory dump of the control unit memory.

RPQ Language Diskette: contains RPQ languages.