

Appendix A

Electrostatic Discharge

A discharge of static electricity from a finger or other conductor can damage printed circuit boards or other static-sensitive devices. This type of damage may reduce the life expectancy of the device.

Preventing Electrostatic Damage

To prevent electrostatic damage, observe the following precautions:

- Avoid hand contact by transporting and storing parts in static-safe containers.
- Keep electrostatic-sensitive parts in their containers until they arrive at static-free work stations.
- Place parts on a grounded surface before removing them from their container.
- Avoid touching pins, leads, or circuitry.
- Always be properly grounded when touching a static-sensitive component or assembly.

Grounding Methods

There are several methods for grounding. Use one or more of the following measures when handling or installing electrostatic-sensitive parts:

- Use a wrist strap connected by a ground cord to a grounded workstation or the computer chassis. Wrist straps are flexible straps with a minimum of 1 megohm +/- 10 percent resistance in the ground cords.
- Use heel straps, toe straps, or bootstraps at standing workstations. Wear the straps on both feet when standing on conductive floors or dissipating floor mats.
- Use conductive field service tools.
- Use a portable field service kit with a folding static-dissipating work mat.

If you do not have any of the suggested equipment for proper grounding, have an Authorized Compaq Service Provider install the part.

NOTE: For additional information on static electricity, or assistance with the installation of this product, contact your Authorized Compaq Service Provider or refer to the Server Maintenance and Service Guide.

Appendix B

Specifications

This appendix provides physical, operating, and performance specifications for the Smart Array 3200 Controller.

Table B-1
Smart Array 3200 Controller Specifications

Dimensions	English	International
Height	3.9 in	9.9 cm
Length	13.75 in	34.9 cm
Thickness (including Array Accelerator)	0.60 in	1.5 cm
Total Weight (including Array Accelerator)	N/A	N/A
Temperature Range		
Operating	50° to 95°F	10° to 35°C
Shipping	-22° to 140°F	-30° to 60°C
Relative Humidity (non condensing)		
Operating	20% to 80%	20% to 80%
Non-operating	5% to 90%	5% to 90%
Power Required		
+5V	2.6 amp	
+12V	20 mA	
-12V	20 mA	
Heat Dissipated (maximum)	13.5 watts	
SCSI Channels	2	
Drives Supported (maximum, internal and external)	15	
Data Transfer Method	32-Bit Bus Master	
SCSI Bus Transfer Rate (maximum)	40 MB/s (20 MHz) per channel	
PCI Bus Transfer Rate (maximum)	132 MB/s	
SCSI Bus Termination	Required	
SCSI Port Connectors (internal and external)	68-pin Wide-Ultra SCSI/Fast-Wide SCSI-2 (Wide SCSI)	

Wide SCSI Connector Pin Assignments

Figure B-1 and Table B-2 identifies the pin assignments of the 68-pin internal and external Wide SCSI connectors.

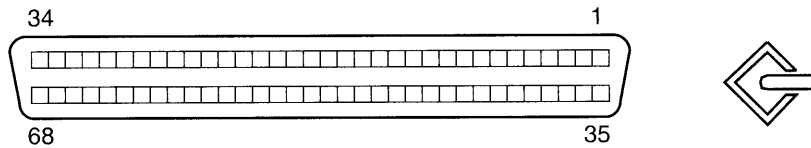

Figure B-1. Wide SCSI Connector

Table B-2
68-Pin Wide SCSI Connector Pin Assignments

Pin	Signal	Pin	Signal
1	N/C	35	DB12*
2	Ground	36	DB13*
3	Ground	37	DB14*
4	Ground	38	DB15*
5	Ground	39	DB Parity 2*
6	Ground	40	DB0*
7	Ground	41	DB1*
8	Ground	42	DB2*
9	Ground	43	DB3*
10	Ground	44	DB4*
11	Ground	45	DB5*
12	Ground	46	DB6*

continued

68-Pin Wide SCSI Connector Pin Assignments *continued*

Pin	Signal	Pin	Signal
13	Ground	47	DB7*
14	Ground	48	DB Parity*
15	Ground	49	Ground
16	Ground	50	Ground
17	TERMPWR	51	TERMPWR
18	TERMPWR	52	TERMPWR
19	N/C	53	Int_Out*
20	Ground	54	Ground
21	Ground	55	ATN*
22	Ground	56	Ground
23	Ground	57	BSY*
24	Ground	58	ACK*
25	Ground	59	RESET*
26	Ground	60	MSG*
27	Ground	61	SEL*
28	Ground	62	C/D*
29	Ground	63	REQ*
30	Ground	64	I/O*
31	Ground	65	DB8*
32	Ground	66	DB9*
33	Ground	67	DB10*
34	Ground	68	DB11*

* - Active low signals



Appendix C

Things You Should Know

This appendix covers general information for the following topics:

- Option Kit Contents
- SCSI Termination
- SCSI IDs
- SCSI Cabling
- SCSI Cable Connectors
- Migrating to/from other controllers

Smart Array 3200 Controller Option Kit Contents

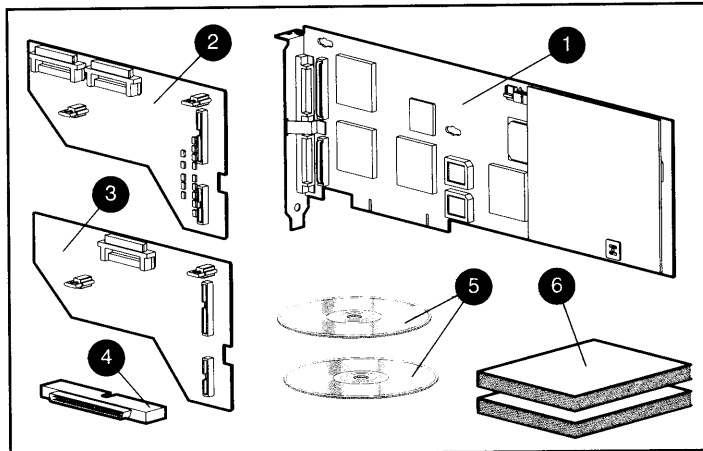

Figure C-1. Smart Array 3200 Option Kit contents

- ① Smart Array 3200 Controller
Option Kit PN 340862-001
- ② Optional daughter board
- ③ Optional daughter board
- ④ SCSI Cable Adapter
- ⑤ Compaq SmartStart and Support Software CD and Storage and Options
Documentation Library CD
- ⑥ Smart Array 3200 Controller Reference Guide and Installation Guide

SCSI Termination

All SCSI buses require termination on both ends of the bus to prevent signal degradation. The Smart Array 3200 Controller supplies the termination on the origination end of the SCSI bus. All internal SCSI cabling recommended for Compaq servers provides the necessary termination for the opposite end of the bus. Therefore, individual SCSI drives in Compaq servers should not contain bus termination.

External SCSI devices must also provide termination for the SCSI bus. This is supplied in Compaq external storage systems such as the ProLiant Storage System or SCSI Storage Expander. Therefore, individual SCSI drives in Compaq storage systems should not contain bus termination.

SCSI IDs

The Smart Array 3200 contains two SCSI buses (ports), each of which supports up to 15 drives. The internal and external connectors reside on separate SCSI buses; peripherals attached to either connector must have a unique SCSI ID in the range of 0 to 6, 8 to 15. SCSI IDs on all peripherals are set manually with switches or jumpers on the device itself or set automatically on Compaq products that support hot-pluggable drives. The SCSI ID determines the device's priority when attempting to use the SCSI bus. The highest priority, SCSI ID 7, is reserved for use by the controller.

SCSI Cabling

The cables available from Compaq that connect your Smart Array 3200 Controller option board to SCSI drives in any Compaq server or external SCSI product can be found:

- in the *Smart Array 3200 Controller Installation Guide*, or
- at www.compaq.com/products/servers/servername/scsicableguide.html, or
- in the Setup and Installation Guide or Reference Guide that accompanied your server.

Use this information to determine your cabling requirements and order the cable option kit number from your local Compaq Reseller or Authorized Compaq Service Provider.

SCSI Cable Connectors

To help identify the SCSI cables required for a Smart Array 3200 Controller installation in the various configurations of Compaq servers, refer to Figure C-2. Keep in mind these characteristics of SCSI cables:

- External SCSI cables have a round wire with securable connectors.
- Internal SCSI cables have a flat ribbon wire with push-on connectors.

C-4 Things You Should Know

- Compaq SCSI cables are keyed so they cannot be installed incorrectly.
- Fast-Wide SCSI-2 and Wide-Ultra SCSI (Wide SCSI) internal ribbon cables are physically narrower than Fast-SCSI-2 (standard SCSI) cables.

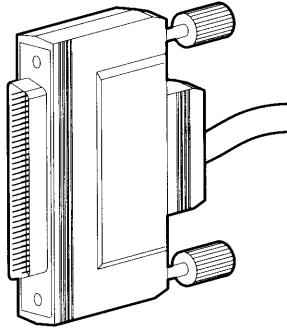

External Wide-Ultra SCSI/Fast-Wide SCSI-2
(Wide SCSI) 68-Pin

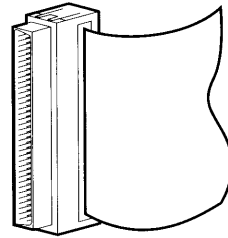

Internal Wide-Ultra SCSI/Fast-Wide SCSI-2
(Wide SCSI) 68-Pin

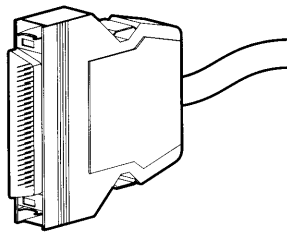

External Fast-SCSI-2
(Standard SCSI) 50-Pin

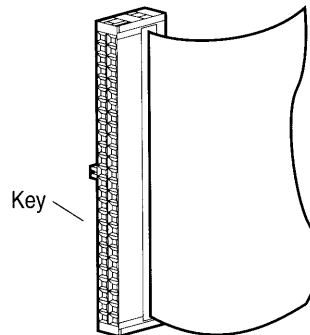

Internal Fast-SCSI-2
(Standard SCSI) 50-Pin

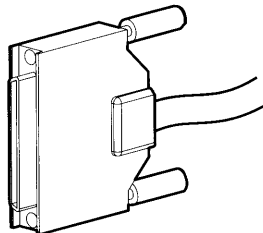

VHDCI Cable

Figure C-2. Identifying SCSI cable connectors

Migrating to/from Other Controllers

The table below indicates what actions, if any, are required when migrating from one array controller type to another.

NOTE: It is recommended that any time you move drive arrays or change your configuration, you should back up data.

Table C-1
Migrating to/from Other Controllers

TO	SMART-1	SMART-2/E	SMART-2/P	SMART-2SL	SMART-2DH	3100ES and 3200
FROM						
SMART-1	X	X	X	X	X	X
SMART-2/E	BU/Restore	X	X	X	X	X
SMART-2/P	BU/Restore	X	X	X	X	X
SMART-2SL	BU/Restore	FW Upgrade	FW Upgrade	X	X	X
SMART-2DH	BU/Restore	FW Upgrade	FW Upgrade	X	X	X
3100ES 3200	BU/Restore	BU/Restore	BU/Restore	BU/Restore	BU/Restore	X

LEGEND:

X: No action required; backup of data is recommended prior to migrating to another controller.

BU/Restore: Backup and restore of data is mandatory to prevent data loss.

FW Upgrade: Upgrade of SMART-2/E or SMART-2/P Controller FW to v1.90 or later is recommended to allow connection of drive arrays to either SCSI bus. However, if a logical volume spans both ports, the drives must be connected to the same port as they were with the original controller. In all cases, drives within a volume maintain their same relative order.



Appendix D

Understanding Drive Arrays

This chapter explains drive array concepts, data protection methods (including fault tolerance options), and data reliability features of the Smart Array 3200 Controller. The following general information will help you understand terms and concepts required for configuration.

What is a Drive Array?

A drive array is a collection of hard disk drives or *physical drives* that are grouped together to create an *array* of physical drives. An array is made up of one or more subsets called *logical drives* (sometimes called logical volumes), which are spread across all physical drives in the array. Operating systems view logical drives as a single, contiguous storage space, although it is made up of parts of several physical drives.

The generic drive array illustrated in Figure D-1 consists of two logical drives spread across three physical drives. Figures D-2 through D-4 illustrate other drive array configurations.

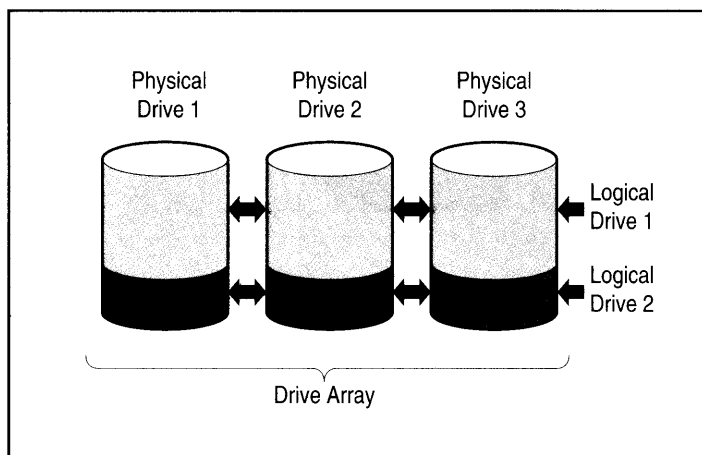

Figure D-1. Drive array with two logical drives

A drive array can also consist of a single logical drive, as illustrated in Figure D-2.

D-2 Understanding Drive Arrays

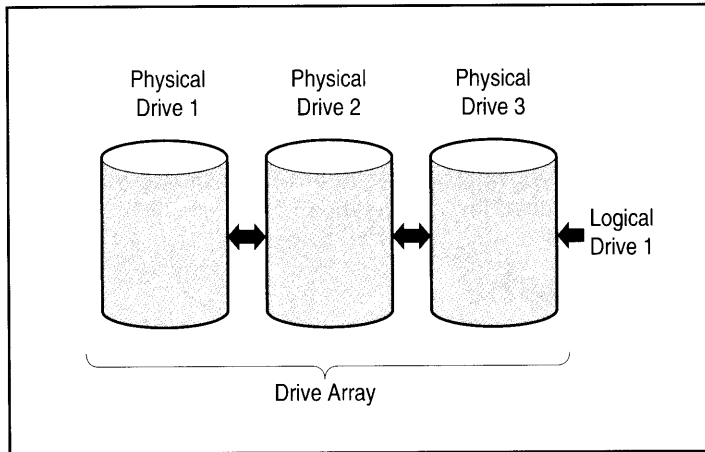

Figure D-2. Drive array with one logical drive

Figure D-3 illustrates a larger array with two logical drives across six physical drives.

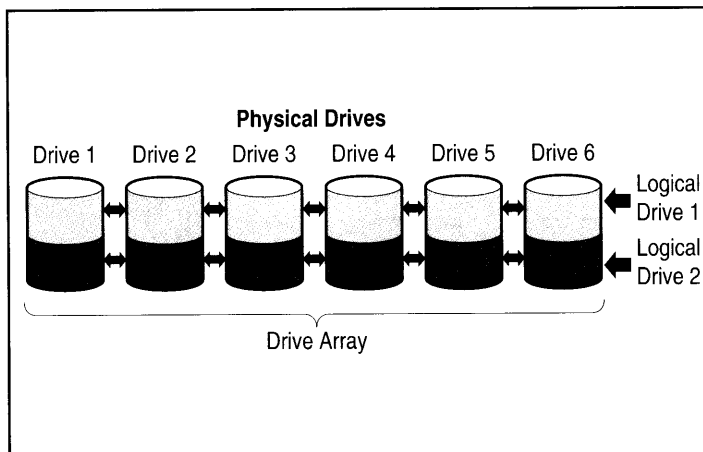

Figure D-3. Drive array with six physical drives and two logical drives

The same physical drives may also be arranged into separate arrays, as illustrated in Figure D-4. Both arrays may be handled by the same controller.

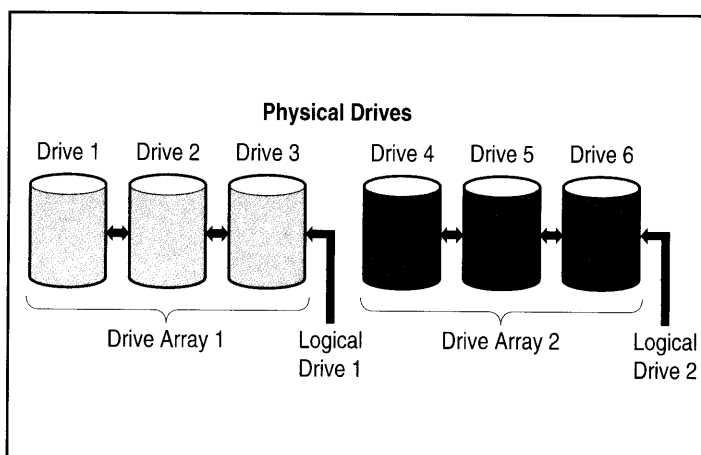

Figure D-4. Two drive arrays with six physical drives

Drive Arrays

Important drive array characteristics of the Smart Array 3200 include:

- A single array cannot span more than one Smart Array 3200 Controller.
- A single Smart Array 3200 Controller can control multiple arrays.
- Arrays must have at least one and may have up to 30 physical drives. (The maximum number of drives is limited to the number of drives that can be installed with the controller.)
- Arrays consist of at least one and may have up to 32 logical drives (maximum 32 logical drives per controller).
- For maximum space efficiency, all drives in a single array should be the same capacity.

Logical Drives

A logical drive is storage space that is distributed across *all* physical drives in an array (except for online spares)—see Figure D-3. Distributing the storage space provides these advantages:

- Data can be accessed on all the physical drives at once, resulting in much higher performance data storage and retrieval.
- Fault tolerance methods may be used to protect your data against hardware failures.

An array can consist of several logical drives, each spanning all of the physical drives in the array. It is important to note that the part of any one logical drive residing on each physical drive is the same size. This means that for maximum space efficiency, all physical drives in each array should also be the same size.

The following are important characteristics of logical drives:

- There must be at least one and up to 32 logical drives in an array (maximum 32 logical drives per controller).
 - Logical drives in an array may be different sizes.
 - Logical drives in an array may use different fault tolerance methods (RAID levels).
 - The portion of a logical drive on each physical drive is the same size.
-

Drive Array Benefits

Using drive arrays with the Smart Array 3200 Controller has several important benefits:

- Data Protection
- Performance Enhancement
- Capacity Changes
- Data Reliability

Data Protection

The Smart Array 3200 Controller provides several options to produce data redundancy for a more reliable system including distributing data, fault tolerance methods, assigning online spares, and rebuilding data.

Fault Tolerance (RAID) Options

During configuration, you will make RAID (Redundant Arrays of Independent Disks) level choices. RAID is the term used for an array technology that provides data redundancy to increase system reliability and performance.

RAID levels range from RAID-5 to RAID-0. The Smart Array 3200 Controller supports the following levels of RAID:

- RAID 5 - distributed data guarding
- RAID 4 - data guarding
- RAID 1 - drive mirroring (also RAID 0+1, or RAID 10)
- RAID 0 - no fault tolerance (data striping only)

The fault tolerance method you choose affects the amount of available disk storage capacity and performance of your drive array. Table D-1 lists the supported RAID levels and illustrates how the fault tolerance methods affect performance and capacity.

**Table D-1
RAID Level Characteristics**

	Distributed Data Guarding (RAID 5)	Data Guarding (RAID 4)	Mirroring (RAID 1)	No Fault Tolerance (RAID 0)
Usable Disk Space*	67% to 97%	67% to 97%	50%	100%
Disk Space Formula (n = no. of drives)	$(n-1)/n$	$(n-1)/n$	$n/2$	n
Parity and Data Redundancy	Parity distributed over each drive	Dedicated parity drive	Duplicate data	None
Minimum Number of Drives	3	3	2	1
Comments	Tolerant of single drive failures. Higher performance than RAID 4. Uses the least amount of storage capacity for fault tolerance.	Tolerant of single drive failures. Like RAID 5, uses the least amount of storage capacity for fault tolerance.	Tolerant of multiple, simultaneous drive failures. Higher performance than RAID 4 or 5. Uses the most storage capacity for fault tolerance. Requires an even number of drives.	Best performance, but data is lost if any drive in the logical drive fails. Uses no storage space for fault tolerance.

* All drives are the same capacity

If you require a fault-tolerant system for critical data, Compaq recommends using RAID 5 for maximum storage space efficiency or RAID 1 if I/O performance is more important.

If you store non-critical data, and space and performance are both important, RAID 0 offers the best of both parameters. However, RAID 0 has no data protection and you will have to rely on backups in case of hardware failure.

Distributed Data Guarding (RAID 5)

Distributed data guarding, also called RAID 5, stores parity data across all the drives in the array. Spreading the parity across all the drives allows more simultaneous read operations and higher performance than data guarding (RAID 4). If a drive fails, the controller uses the parity data and the data on the remaining drives to reconstruct data from the failed drive. This allows the system to continue operating with a slightly reduced performance until you replace the failed drive.

Distributed data guarding requires an array with a minimum of three physical drives and allows a maximum of 30 drives. Therefore, in an array containing three physical drives, distributed data guarding uses only 33 percent of the total logical drive storage capacity for fault tolerance; a 14-drive configuration uses only 7 percent, and a 30-drive configuration uses only 3 percent.

NOTE: Given the reliability of a particular generation of hard drive technology, the probability of an array experiencing a drive failure increases with the number of drives in an array. Compaq recommends the number of drives in an array be limited to 15.

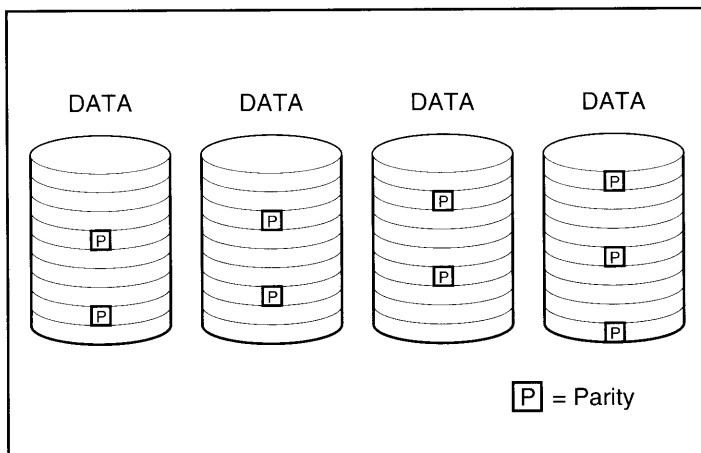

Figure D-5. Distributed Data Guarding distributes the redundant data [P] throughout the physical drives

Data Guarding (RAID 4)

Data guarding, also called RAID 4, assures data reliability while using only a small percentage of the logical drive storage capacity. A designated, single drive contains parity data. If a drive fails, the controller uses the data on the parity drive and the data on the remaining drives to reconstruct data from the failed drive. This allows the system to continue operating with slightly reduced performance until you replace the failed drive.

Data guarding requires a minimum of three drives (two data drives and one parity drive) in an array and allows a maximum of 30 drives (29 data drives and one parity drive). For example, in an array containing three physical drives, data guarding uses only 33 percent of the total logical drive storage capacity for fault tolerance. A 14-drive configuration (13 data drives, one parity drive) uses only 7 percent; a 30-drive configuration (29 data drives, one parity drive) uses only 3 percent.

NOTE: Given the reliability of a particular generation of hard drive technology, the probability of an array experiencing a drive failure increases with the number of drives in an array. Compaq recommends the number of drives in an array be limited to 15.

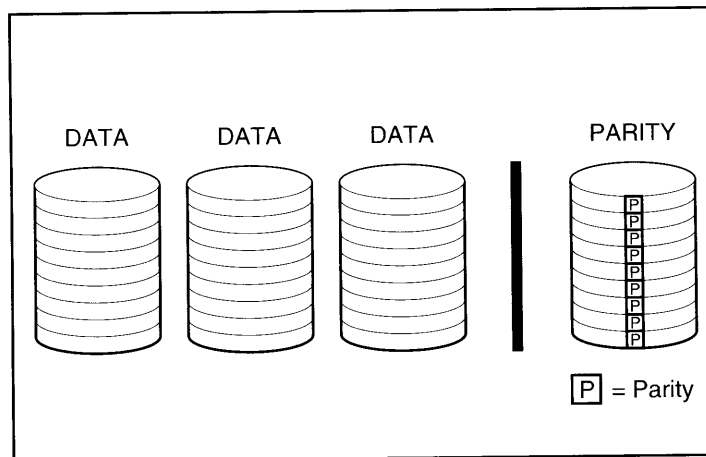

Figure D-6. Data Guarding stores redundant data [P] on a separate drive

The Smart Array 3200 supports RAID 4 for backward compatibility. Because RAID 5 provides the same benefits with higher performance, Compaq recommends using RAID 5 instead of RAID 4.

Drive Mirroring (RAID 1)

Drive mirroring, also called RAID 1, is the highest-performance fault tolerance method. RAID 1 is the only method for fault tolerance protection if only two drives are installed or selected for an array. Drive mirroring creates fault tolerance by storing two sets of duplicate data on a pair of disk drives. Therefore, RAID 1 is the most expensive fault tolerance method because 50 percent of the drive capacity is used to store the redundant data. RAID 1 always requires an even number of drives. To improve performance in configurations with more than two drives, the data is striped across the drives. This is also referred to as RAID 0+1 or RAID 10.

If a drive fails, the mirror drive provides a backup copy of the files and normal system operations are not interrupted. The mirroring feature requires a minimum of two drives and, in a multiple drive configuration (four or more drives), mirroring can withstand multiple simultaneous drive failures as long as the failed drives are not mirrored to each other.

IMPORTANT: If two drives being mirrored to each other fail, the volume is failed and data loss may occur.

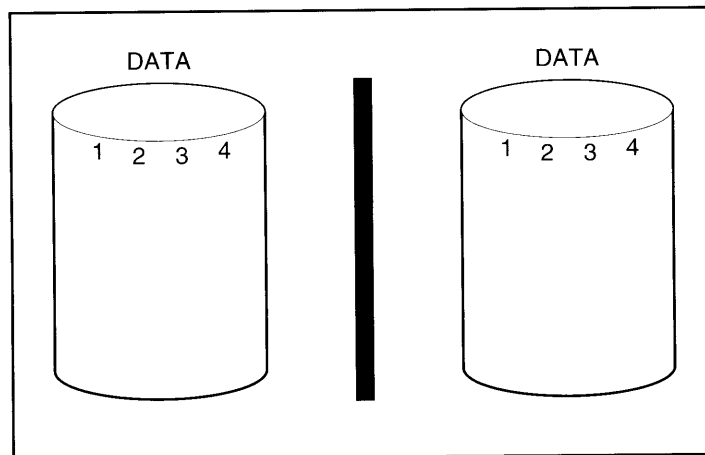

Figure D-7. Drive mirroring stores identical copy of the data

No Fault Tolerance (RAID 0)

RAID 0 does not provide fault tolerance. This level of RAID stripes data across all the drives of the array, but it does not incorporate a method to create redundant data. Therefore, if you choose this RAID option for any of your logical drives, you will experience data loss for that logical drive if one physical drive fails.

However, because none of the capacity of the logical drives is used for redundant data, RAID 0 offers the best processing speed and capacity. For this reason, you may consider assigning RAID 0 to drives that require large capacity and high speed but do not contain critical data.

Before choosing the RAID 0 option, be sure to consider the following:

- Disk failure will result in data loss for all RAID 0 logical drives.
- You cannot assign an online spare to an array containing a RAID 0 logical drive.

Online Spare

During configuration, consider assigning an online spare to further improve your system's fault tolerance. An online spare (sometimes called a hot-spare) is a drive the controller uses when a drive failure occurs. If a drive fails, the controller rebuilds the data that was on the failed drive onto the online spare. The controller also sends data that it would normally store on the failed drive directly to the online spare.

The online spare improves the overall system fault tolerance by automatically replacing a failed drive and quickly restoring the system to full RAID fault tolerance protection. During the time the system is operating in interim recovery mode with the failed drive, the system is vulnerable to an additional drive failure.

You can install up to four online spares for each Smart Array 3200 Controller. To provide an online spare, you must have at least one installed but unassigned physical drive and the system must be running some type of fault tolerance method (RAID 1, RAID 4, or RAID 5).

Spare drives are assigned automatically to all volumes in an array and can be assigned to multiple arrays connected to the same controller.

Performance Enhancement

Drive arrays allow data access performance to be dramatically enhanced over non-arrayed drives. In addition, the Smart Array 3200 has several other performance enhancement features that are discussed in this section.

Distributing Data and Data Striping

Distributing data makes it possible to access data concurrently from multiple drives in an array. This yields I/O rates many times faster than non-arrayed drives. Distributing data allows data striping.

Data striping is automatically generated on an array controller in order to store user data. A stripe is a collection of contiguous data that is distributed evenly across all physical drives in a logical drive. The width of the stripe (the amount stored on each physical drive) is selected to optimize the performance of the operating system.

For example, consider an operating system that typically requests data in 32-sector blocks (a sector contains 512 bytes of data). The Smart Array 3200 distributes the data so that the first 32 sectors of data are on the first drive in the array. The Smart Array 3200 continues distributing the next 32 sectors on the second drive, the next 32 sectors on the third drive, and so on. Evenly distributed user data across all drives in an array results in improved performance by allowing data access to all drives simultaneously.

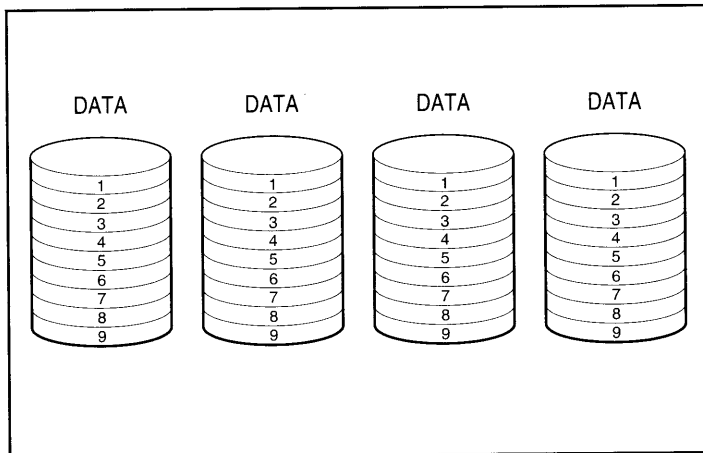

Figure D-8. Data Striping distributes data across all physical drives

User Selectable Stripe-size

You may change stripe-size either during the initial configuration of the system, or later after the system has been in use for some time. In both cases this must be performed offline. See Chapter 5 for instructions to set or change stripe-size. Table D-2 lists the set of valid stripe sizes for each RAID level highlighting the default values.

Table D-2
Stripe Sizes

Fault Tolerance Level	Default (KB)	Default (Sectors)	Valid Stripe Sizes (Sectors)
RAID 0	128 *	256	16, 32, 64, 128, 256*, 512
RAID 1	128 *	256	16, 32, 64, 128, 256*, 512
RAID 4	16 *	32	16, 32*, 64, 128
RAID 5	16 *	32	16, 32*, 64, 128
* Default			

*RAID 4 and 5 do not support stripe sizes larger than 64-KB per drive.

Because data is re-written to the drives in a different format, the Write cache must be enabled (batteries charged) to protect the data in the event of power loss during the change. Also, the Array Accelerator memory must be large enough to support the least common multiple of the two different full stripe sizes. During an expand/stripe-size change from an 11-drive RAID 5 volume (default, 32 sectors; full stripe = 320 sectors) to a 14-drive RAID 1 volume (default, 256 sectors; full stripe = 1792 sectors), the least common multiple of a full stripe would require 8960 sectors (4480 KB) available in the Array Accelerator.

The number of sectors on the physical drives may not be increased. This can occur as a result of a request to increase stripe-size; the newly selected stripe-size would not be allowed. For example, if the user desires to change the stripe-size from 32 to 256 sectors, there may not be enough sectors at the end of the disks for a complete stripe of the larger size. Since a partial stripe cannot be supported, the request would not be allowed. In a new configuration, the area at the end of the disks is not used if there are not enough sectors left for that particular stripe-size. To select the new stripe-size, the current configuration would have to be deleted and the array configured with the new stripe-size. Since the data would be destroyed, you would need to backup the data and restore it after the array was reconfigured.

Array Accelerator

By serving as a posted write cache and read-ahead cache, the Smart Array 3200 Array Accelerator dramatically improves the performance of read and write commands. The Array Accelerator is particularly useful for increasing performance in database and fault-tolerant configurations.

Performance

The Array Accelerator increases performance by having the Smart Array 3200 write data to the cache memory on the Array Accelerator rather than directly to the drives. The system can access this cache memory more than 100 times faster than accessing disk storage. The Smart Array 3200 writes the data in the Array Accelerator to the drive array at a later time, when the controller is otherwise idle.

The controller also uses the Array Accelerator to increase performance by anticipating requests. The Array Accelerator uses a multi-threaded algorithm to predict the next likely read operation for the array. That data is read into the Array Accelerator and, therefore, is ready before you access it. When the Smart Array 3200 receives a read request for the cached data, it can be burst immediately into system memory at PCI bus speeds.

Data Protection

The Array Accelerator was designed to protect data integrity. Batteries and ECC memory protect the cache memory. This allows users to take full advantage of the performance without sacrificing reliability.

The Array Accelerator is also removable. This, along with its integrated batteries, means the Array Accelerator may be removed from one Smart Array 3200 Controller and installed on another. If there is any data in the Array Accelerator that has not been written to the hard drive, it can be transferred to another Smart Array 3200 Controller. This might happen if the Smart Array 3200 Controller or server failed before the cached data could be stored on a drive.

ECC Memory

To assure further data integrity, the Array Accelerator cache is made up of Error Checking and Correcting (ECC) memory. ECC memory detects and corrects all single-bit memory errors in multiple DRAMs. It also detects all two-bit memory errors in any position and most three- and four-bit memory errors in a single DRAM. An entire DRAM can also fail without data loss. This ensures the correction of common memory errors without interrupting system operation.

Batteries

The Array Accelerator contains batteries that maintain any data cached there if a system power failure occurs. The batteries can preserve data in the Array Accelerator for up to four days. When power is restored to the system, an initialization process writes the preserved data to the disk drives.

The cells used in the Array Accelerator batteries are recharged via a “trickle” charge applied while system power is present. If posted writes were stored in the memory of the Array Accelerator and power loss occurs, you must reinstate power within approximately four days or the data stored in the memory will be lost; this depends on the present condition of the Array Accelerator batteries.



IMPORTANT: It is possible for the batteries to be depleted when you install a new Smart Array 3200. It can take up to 36 hours of system operation to charge the batteries fully. In this case, only the Array Accelerator is affected; your system will continue to run without interruption.

During Power-On Self-Test (POST), the Smart Array 3200 checks the batteries. If the battery charge is low or depleted, a 1794 POST error message displays, indicating that the Array Accelerator is disabled. The controller temporarily disables the Array Accelerator until the batteries reach 90 percent charge. The board continues to function properly, at a slightly lower performance, until the batteries reach 90 percent charge. At this point, the Array Accelerator is enabled automatically.

Concurrent I/O Request Servicing

The Smart Array 3200 can service hundreds of I/O requests at a time. For example, if you request data that resides on the first drive and another user requests data that resides on the second drive, the controller delivers both pieces of information concurrently. Figure D-9 illustrates concurrent request servicing.

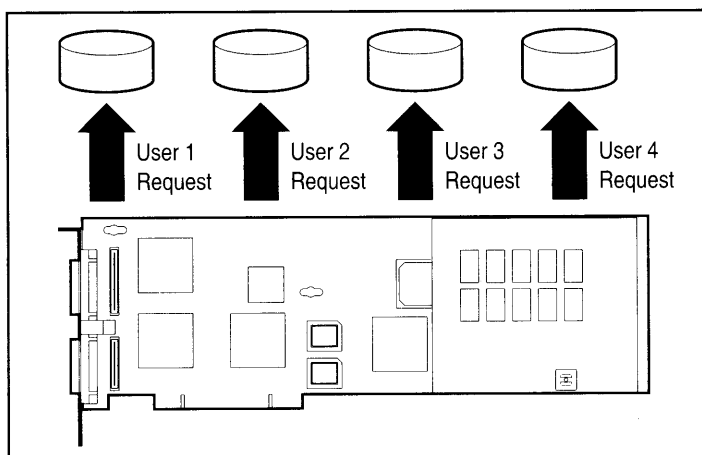

Figure D-9. Concurrent Request Servicing handles several I/O requests

Optimized Request Management

Optimized Request Management, also known as elevator trend sorting, is another performance enhancement feature provided by the Smart Array 3200. The controller receives and queues multiple data requests from the operating system. The controller then rearranges the requests in an order that optimizes performance.

For example, the Smart Array 3200 receives a request for a physical drive that is not currently active. The controller schedules the request immediately ahead of previously received requests already queued to other active drives within the array. This request management process operates concurrently with drive operations. The benefits of optimized request management increase as greater demands are made on the drive subsystem.

Bus Master Data Transfers

The Smart Array 3200 Controller is a bus master device that takes control of the PCI bus during high-speed transfers. This allows the system processor to handle application processing or other types of tasks. Data transfer occurs at rates of up to 133 megabytes per second for the PCI bus. Bus master high-speed transfers are particularly important when the supported models are used in conjunction with multiple expansion boards such as network interface controllers (NICs).

Expanding Storage Capacity

The Smart Array 3200 allows the configuration of one or more separate logical drives into a single drive array. An existing drive array can be expanded by adding one or more logical drives to the array. To create the room for the additional logical drives, more physical drives must be added. See Figure D-10.

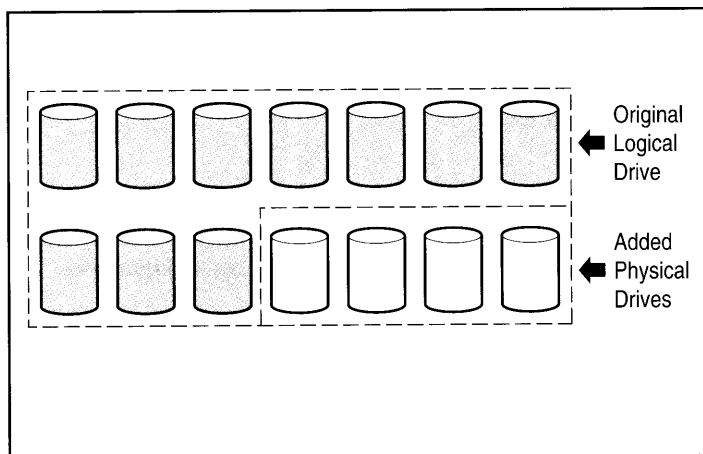

Figure D-10. Begin capacity expansion by adding more physical drives

When initiated by the Array Configuration Utility, the Smart Array 3200 automatically redistributes the data in the original logical drive to a logical drive that spans all of the physical drives in the array, including the added drives. The room left over is used to create additional logical drives, also spanning all physical drives. Both logical drives are then included in the drive array with expanded storage capacity. See Figure D-11.

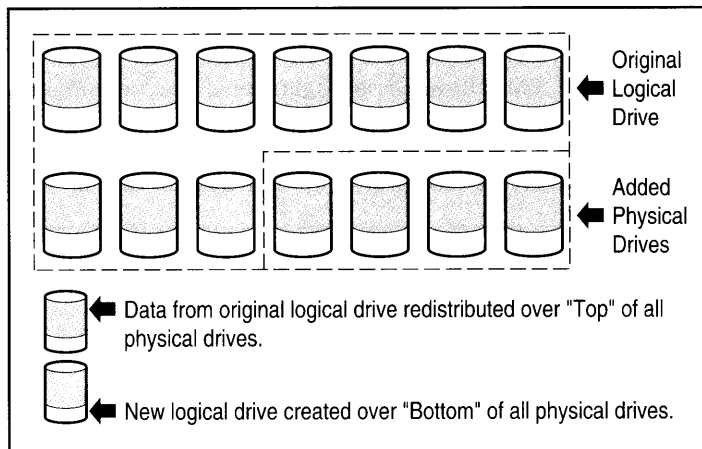

Figure D-11. Expanded array storage capacity with a second logical drive

Example: Assume you have two ProLiant Storage Systems with a total of 10 drives and you want to expand this to 14 drives (the Smart Array 3200 supports up to 30 drives). With Array Configuration Utility running, simply install four matching drives in the empty drive bays. At this point your array will resemble Figure D-10, with the original data (original logical drive) represented by the gray shaded drives and the new drives unshaded. Run the Array Configuration Utility, which is located on the Compaq SmartStart and Support Software CD, to start the expansion process described in Chapter 5.

The Smart Array 3200 redistributes the data to an equal portion of all the drives, using the same fault tolerance method as the original configuration. The first logical drive remains first, but it now spans 14 drives instead of 10. The Array Configuration Utility also detects the unused space on each drive (because each drive contains 10/14ths of the data that it used to) and helps you configure it into a second logical drive with its own fault tolerance, distributed over the extra space of all the drives.

When this process is finished both logical drives, one containing the original data and the new empty one, will be configured into a single array with more total capacity than the original one. Now your array will resemble Figure D-11, using the same shading scheme to represent the logical drives.

It is not necessary for all *logical drives* in an array to be the same size or even have the same fault-tolerant configuration. Each logical drive is treated as a separate entity no matter how many physical drives it crosses. Each may be configured as best suits your needs.

It is important to remember that all *physical drives* in an array should be the same size (capacity). This is because each drive contains an equal portion of one or more logical drives and the portion sizes can only total the size of the smallest drive. While you are not prevented from expanding storage capacity with larger drives, the extra space cannot be used.

During expansion of an array that initially has two or more logical drives, the redistribution of data takes place one logical drive at a time. When the capacity expansion has completed, any newly created logical drive will become available. Under Windows NT and NetWare, the new logical drive can then be appended to your existing logical volume.

Online Capacity Expansion

In certain cases, the Smart Array 3200 and the Array Configuration Utility also support making storage capacity changes online, without downing the server or storage system. These cases are:

- Windows NT or NetWare operating system (NetWare 3.11 not supported)

and

- Hot-Plug drives

Because the Array Configuration Utility reconfigures the Smart Array 3200, online reconfiguration can only take place if Array Configuration Utility is running in the same environment as the normal server applications.

Hot-plug drives are required for online storage changes because non-hot-plug drives require that the server be powered down to add or remove the drive. All ProLiant Servers and Storage Systems support hot-plug drives.

Disk Drive Upgrades

Additional storage space can be gained with the same number of physical drives *in a fault-tolerant configuration* by replacing these drives with higher-capacity drives. By replacing the drives one at a time, the data on the new drive is recreated from redundant information on the remaining drives. After each new drive has been rebuilt, the next can be replaced. After all drives have been replaced and rebuilt, the additional capacity on each drive can be utilized by adding a new logical drive. The Array Configuration Utility automatically recognizes the unused space and guides you through the procedures to use it.

Other Fault Management Features

The Smart Array 3200 and the network operating system support several other fault management and data reliability features. These features include:

- Auto reliability monitoring
- Dynamic sector repairing
- Drive parameter tracking
- Drive failure alert features
- Interim data recovery
- Automatic data recovery
- Hot-plug drives (Compaq ProLiant Storage System, Compaq ProLiant Server, Rack-Mountable Compaq ProLiant Storage System or Rack-Mountable Compaq ProLiant Server)

The following functions are not Smart Array 3200 features, but may be supported by the operating system:

- Controller duplexing
 - Software-based drive mirroring
-

Auto Reliability Monitoring

Auto Reliability Monitoring (ARM) is a background process that scans hard drives for bad sectors in fault-tolerant logical drives. ARM also verifies the consistency of parity data in drives with data guarding or distributed data guarding. This process assures that you can recover all data successfully if a drive failure occurs in the future. ARM operates only when you select RAID 1, RAID 4, or RAID 5.

Dynamic Sector Repairing

Using the dynamic sector repairing process, the controller automatically remaps any sectors with media faults it detects either during normal operation or during auto reliability monitoring.

Drive Parameter Tracking

Drive parameter tracking monitors more than 15 drive-operational parameters and functional tests. This includes parameters such as read, write, and seek errors; spin-up time; cable problems; and functional tests such as track-to-track seek time, one-third stroke, and full stroke seek time. Drive parameter tracking allows the Smart Array 3200 to detect drive problems and predict drive failure before they actually occur. It also makes pre-failure warranty possible on Compaq disk drives.

Drive Failure Alert Features

Drive failure features produce various drive alerts or error messages depending on the Compaq server model. Refer to the documentation included with your server to determine what drive failure features are included on your server model.

Other Compaq options such as Compaq Insight Manager and Compaq Server Manager/R provide additional drive failure features. See your Authorized Compaq Reseller for more information on these products.

Interim Data Recovery

In RAID 5, RAID 4, or RAID 1 fault-tolerant configurations, if a drive fails, the system continues to operate in an interim data recovery mode. For example, if you selected RAID 5 for a logical drive with four physical drives and one of the drives fails, the system continues to process I/O requests, but at a reduced performance level. Replace the failed drive as soon as possible to restore performance and full fault tolerance for that logical drive. See Appendix G for more information on recovering from drive failure.

Automatic Data Recovery

After you replace a failed drive, automatic data recovery reconstructs the data and places it on the replaced drive. This allows a rapid recovery to full operating performance without interrupting normal system operations.

In general, the time required for a rebuild is approximately 15 minutes per gigabyte. However, the actual rebuild time depends on the rebuild priority set for the amount of I/O activity occurring during the rebuild operation, disk drive speed, and the number of drives in the array (RAID 4 and RAID 5). In RAID 4 and RAID 5 configurations, the rebuild time varies from 10 minutes/GB for three drives to 20 minutes/GB for 14 drives (using 9-GB Wide-Ultra hard drives).

NOTE: You must specify RAID 5, RAID 4, or RAID 1 through the Array Configuration Utility to make the recovery feature available. The drive failure alert system and automatic data recovery are functions of the Smart Array 3200; they function independently of the operating system.

Hot-Plug Drives

The Smart Array 3200, used with a Compaq ProLiant Storage System, a Rack-Mountable Compaq ProLiant Storage System, a Compaq ProLiant Server, or Rack-Mountable Compaq ProLiant Server, supports hot-plug drives. You can install or remove these drives without turning off the system power. This feature is a function of the Compaq ProLiant Storage System and the Compaq ProLiant Server and operates independently of the operating system.



CAUTION: Do not turn off the Compaq ProLiant Storage System or the Compaq server when removing or installing the hot-plug replacement drives. If you turn off the ProLiant Storage System while the server power is on, the Smart Array 3200 Controller marks all the drives as “failed.” This could result in permanent data loss when the Storage System is turned back on.

If a drive fails, the Service Required LED on the front panel of the Compaq ProLiant lights, indicating that a problem has occurred. Refer to your server documentation for more information on replacing drives. Also see Figure D-12 for conditions to safely replace a drive using the three indicators on each of the hot-plug drive trays.

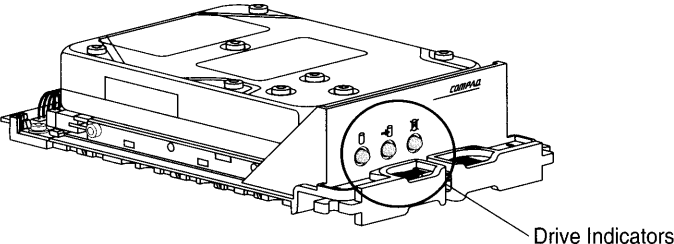

	OK to remove drive if not part of fault-tolerant configuration
	OK to remove failed drive
	DO NOT remove drive
	DO NOT remove drive
	DO NOT remove drive
	DO NOT remove drive
	DO NOT remove drive

OFF
 ON

Figure D-12. Hot-plug drive replacement conditions

Controller Duplexing

Some operating systems support controller duplexing, a fault tolerance feature that requires two Smart Array 3200 Controllers. With duplexing, the two controllers each have their own drives that contain identical data. In the unlikely event of a Smart Array 3200 Controller failure, the remaining drives and the Smart Array 3200 Controller service all requests.

Controller duplexing is not the same as duplexing the SCSI buses on a single Smart Array 3200 Controller. Controller duplexing is a function of the operating system and takes the place of other fault tolerance methods. Refer to the documentation included with your operating system for implementation.

Compaq recommends using hardware-based fault tolerance instead of controller duplexing. Hardware-based fault tolerance provides a much more robust and controlled environment for fault tolerance protection.

If you choose controller duplexing, configure each Smart Array 3200 with RAID 0 to achieve maximum storage capacity. In addition, the following fault-tolerant features will not be available: online spare, auto-reliability monitoring, interim data recovery, and automatic data recovery.

Software-Based Drive Mirroring

Some operating systems support software-based drive mirroring as a fault tolerance feature. Software drive mirroring resembles hardware-based drive mirroring (RAID 1), except that the operating system mirrors logical drives instead of physical drives.

A pitfall of software-based drive mirroring is that the operating system believes each logical drive is a separate physical drive. If you mirror logical drives in the same array and a physical drive fails, both logical drives in the mirrored pair will fail. You will not be able to retrieve your data.

Because software-based drive mirroring is a function of the operating system, refer to the documentation included with your operating system for implementation.

Compaq recommends using hardware-based fault tolerance instead of software-based fault tolerance. Hardware-based fault tolerance provides a much more robust and controlled environment for fault tolerance protection.

If you choose software-based drive mirroring, create at least two arrays with RAID 0 to achieve maximum storage capacity. Then, when configuring the drive mirroring through the operating system, mirror logical drives residing in different arrays. In addition, the following fault-tolerant features will not be available: online spare, auto-reliability monitoring, interim data recovery, and automatic data recovery. See Chapter 5 for information on your drive array(s) and fault tolerance.

Appendix E

Replacing the Array Accelerator

The Smart Array 3200 Controller has a removable 64-MB Array Accelerator. The Array Accelerator is mounted on a removable daughter board so that it can be replaced easily if necessary. The Smart Array 3200 Controller is not operable without the Array Accelerator.

The Smart Array 3200 Array Accelerator has several unique features:

- It accelerates data storage by temporarily caching the data at high internal bus rates while transferring the data to the drives at their slower write speeds.
- It uses its own batteries to keep the data alive without board power, even if the Array Accelerator is removed from the Smart Array 3200 Controller.
- The memory is Error Checking and Correcting (ECC), providing error detection and correction reliability.
- It can be moved to another Smart Array 3200 Controller to complete the data transfer should the original Smart Array 3200 Controller fail.

Removing the Array Accelerator

To remove the optional Array Accelerator from the controller board:

1. Twist the latch (❶) 90° to allow the standoff to pull through the controller board.
2. Carefully pull the Array Accelerator daughter board away (❷) from the Smart Array 3200 Controller board, unplugging the signal connectors.

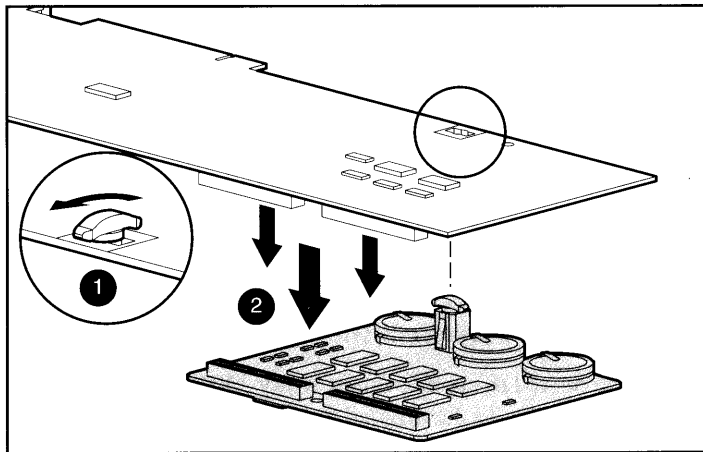

Figure E-1. Removing Array Accelerator board from the Smart Array 3200 Array Controller



WARNING: Do not abuse, recharge, disassemble, dispose of in fire or heat above 90°C, incinerate, or expose to water or fire. Disposal of the batteries or Array Accelerator module should be accomplished within compliance of local regulations or returned to Compaq Computer Corporation by established parts return methods.

Array Accelerator Installation

To install the Array Accelerator board on the Smart Array 3200 Controller:

1. Align the connectors and plug the Array Accelerator board onto the Smart Array 3200 Controller (❶). Be sure the connectors are fully mated by squeezing the boards together at the connector side.
2. Align the plastic standoff on the Array Accelerator board with the slot in the Smart Array 3200 Controller board. Push it through and rotate the top of the standoff 90° to lock the board in place (❷).
3. Align the plastic stabilizing bracket with the holes on both boards, ensuring that the mated boards will fit between the lips on the bracket. Push the bracket in place until the detents snap through the holes.

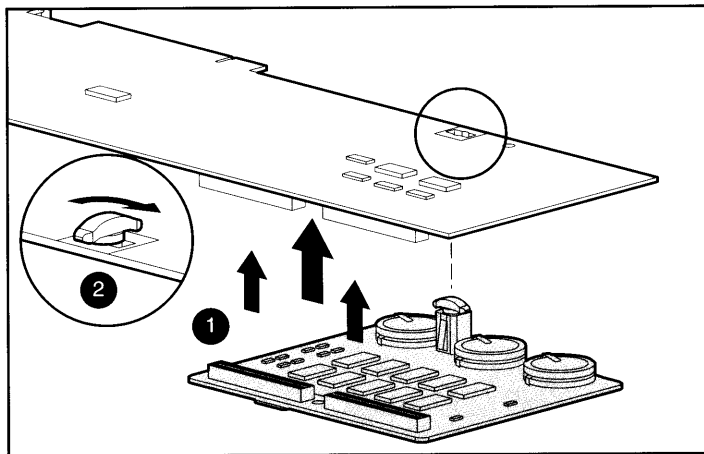

Figure E-2. Installing the Array Accelerator board on the Smart Array 3200 Array Controller



Appendix F

Upgrading from the SMART-2 and Smart SCSI Array Controllers

Users of the original Compaq SMART-2 or SMART SCSI Array Controllers may consider upgrading to the new Smart Array 3200 Controller. This appendix provides upgrade instructions for moving arrayed drives from the either SMART or SMART-2 (SMART-2/E, SMART-2/P, SMART-2SL, and SMART-2DH) Controllers to the Smart Array 3200 Controller. All user data and configuration information will be retained after the upgrade process.

IMPORTANT: Array configuration information is automatically transferred during the upgrade process. However, this is a one-way process. After upgrading to the Smart Array 3200 Controller, a manual reconfiguration procedure is required to move the drives and data back to the SMART or SMART-2 Controller.

IMPORTANT: The upgrade procedure described below applies only to moving drives from SMART or SMART-2 Controllers to the Smart Array 3200. Data will **NOT** be preserved if drives are moved from a Fast SCSI-2 Controller or a Fast-Wide SCSI-2 Controller to a SMART, SMART-2, or Smart Array 3200 Controller.

To upgrade your system by replacing the SMART or SMART-2 SCSI Array Controller with a new Smart Array 3200 Controller, perform the following steps:

1. Back up all affected drives. This is a safety precaution. If done properly, this upgrade procedure will not affect the arrayed data or drive location.
2. Upgrade your operating system device driver to the new Smart Array 3200 driver. The new drivers have been optimized to support the latest features and capabilities of the Smart Array 3200. The driver upgrade process is operating system-dependent. See the Readme file on the Compaq SmartStart and Support Software CD for information on specific operating system drivers.

F-2 Upgrading from the SMART-2 and Smart SCSI Array Controllers

3. Upgrade your System ROM to the most current version using the Compaq System ROMPaq. The System ROM **must** be upgraded before installing the Smart Array 3200 Controller. Your Smart Array 3200 option kit may include a diskette containing System ROMPaq. If so, use the diskette to upgrade the system ROM. Otherwise, System ROMPaq is distributed on the Compaq SmartStart and Support Software CD included in the Smart Array 3200 option kit. Review Chapter 3 in this guide for specific instructions on running System ROMPaq.
4. Perform a normal shutdown and turn OFF the server.
5. It is important to understand the difference between SCSI cable connector layouts for the SMART Controller, SMART-2 Controllers, and Smart Array 3200 Controllers. See Figures F-1 and F-2.

The **SMART Controller** has a 100-pin external connector on the mounting bracket that connects to the Y cable that separates into two 50-pin Fast-SCSI-2 connectors, Port 1 and Port 2. These port numbers should be labeled on the Y cable and can be connected to external drives in Compaq ProLiant Storage Systems or other external storage units. Port 1 is also available as an internal connector on the top edge of the controller for internal drive connections. Port 1 can be used either internally or externally, but not both at the same time. Note the existing cable connections and port numbers for your system before disconnecting any cables.

The **SMART-2DH Controller** has an external 68-pin Fast-Wide SCSI-2 connector on the mounting bracket for Port 2 only. There is an internal 68-pin Fast-Wide SCSI-2 connector at the top edge of the controller for Port 1. This port can be used for internal drives through a standard internal ribbon cable, or for external drives through a special internal/external cable (included) and a connector panel or slot connector bracket (included) at the back of the server. This allows Port 1 connections to external drives in Compaq ProLiant Storage Systems. There is no Y cable used with the SMART-2DH Controller.

The **Smart Array 3200 Controller** has two Very High Density Connector Interface (VHDCI) connectors on the mounting bracket for Ports 1 and 2. Optional daughter boards (included in the Smart Array 3200 option kit) provide one or two 68-pin Wide-Ultra SCSI-3 connectors for internal drives. This provides SCSI ports externally, internally, or both, without additional cabling to route internal channels externally or vice versa. There is no Y cable required for the Smart Array 3200 Controller.

F-4 Upgrading from the SMART-2 and Smart SCSI Array Controllers

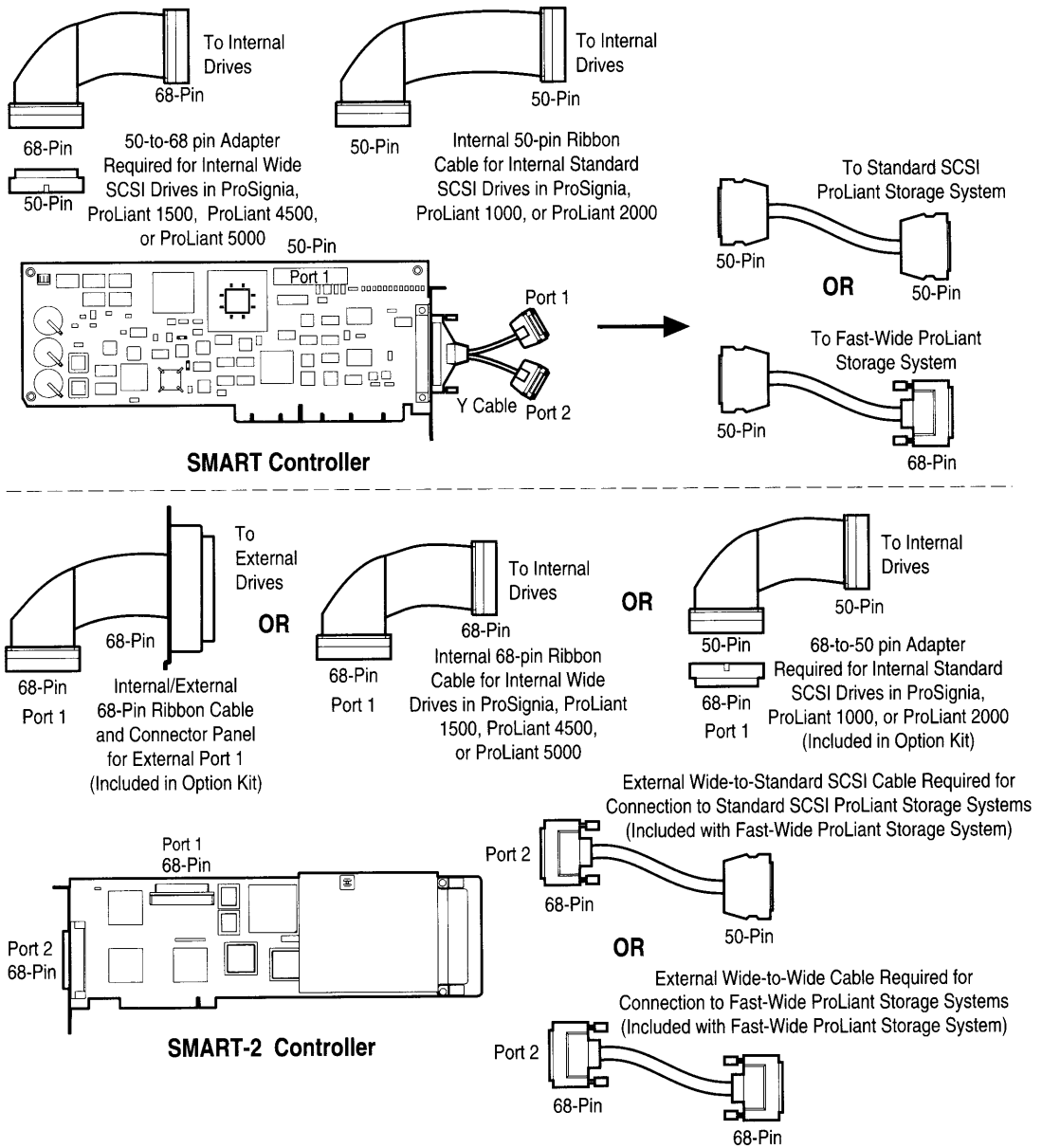
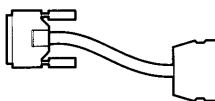

Figure F-1. Cable and connector configurations for SMART and SMART-2 Array Controllers



SMARTArray 3200; Show cabling as shown for both connections.

Port 1
or
Port 2



External VHDCI-to-Standard SCSI ProLiant Storage systems

OR

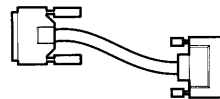

External VHDCI-to-Wide cable required for connection to ProLiant Storage systems. (Included with ProLiant Storage Systems)

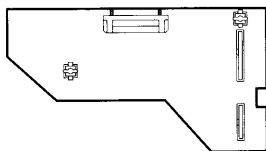

SMARTArray 3200 with single-channel daughter board; Use external and internal addings shown.

Port 1
or
Port 2

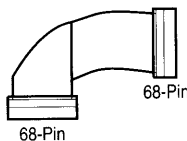

Internal 68-pin ribbon cable added for internal wide drives in ProSignia and ProLiant servers.

OR

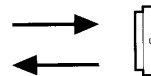

68-to-50 pin adapter required for internal standard SCSI drives in ProSignia, ProLiant 1000, or ProLiant 2000.

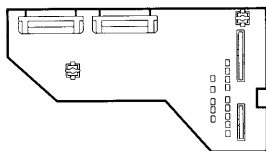

SMARTArray 3200 with dual-channel daughter board; Use internal cablings shown for both connections.

Figure F-2. Cabling configurations for Smart Array 3200 Controller

F-6 Upgrading from the SMART-2 and Smart SCSI Array Controllers

To upgrade, attach disk drives (internal to the server or external to ProLiant Storage Systems) to the same numbered ports as the original controller. **If an array spans both SCSI ports of the old controller, it is necessary to connect internal drives and external ProLiant Storage Systems to the same numbered ports on the Smart Array 3200 Controller as they were on the original SMART or SMART-2 Controller.** If these port connections are wrong, a system power-on (POST) message will advise you to reconnect to the correct ports. If both ports are connected to separate arrays, they may be connected to either port as long as the relative order of the drives in each array is maintained.

The Smart Array 3200 uses two VHDCI external and two 68-pin Fast-Wide SCSI-2 internal connectors on optional daughter boards; therefore:

- ❑ If you are connecting to Fast-SCSI-2 internal drives, you must attach a 68-pin to 50-pin cable adapter (included in the Smart Array 3200 option kit) to an internal connector on the optional daughter board to use your existing 50-pin internal ribbon cable.
- ❑ If you are connecting to a Fast-SCSI-2 external storage system, use a VHDCI to 50-pin external cable, which must be ordered separately.
- ❑ If you are connecting to a Fast-Wide SCSI-2 external storage system, use a VHDCI to 68-pin external cable included with the ProLiant Storage System.

For more detailed information on cable connections for your system, refer to your server documentation.

6. Remove the SMART or SMART-2 Controller and replace it with the Smart Array 3200 Controller. Refer to the *Smart Array 3200 Installation Guide*. It is not necessary to put the new controller in the same expansion slot as the old controller.
 7. Reconnect all internal and external drive cables. Pay close attention to the port numbers as noted in Step 5.
-

8. Turn on the server and run the Compaq System Configuration Utility. This configuration utility recognizes the Smart Array 3200 Controller and allows you to change parameters such as controller order and interrupt number, if needed. You will not see logical drive information with this utility since Smart Array 3200 logical drives are configured with the Compaq Array Configuration Utility. Save the configuration and reboot the server.

You can run the Array Configuration Utility to see the configuration of your logical drive(s), look at fault tolerance level, and so on. However, it is not necessary since your configuration information is automatically preserved.

After completing these steps, the upgrade process is complete. You can now use the Smart Array 3200 Controller.



Appendix G

Recovering from Drive Failure

The purpose of fault-tolerant configurations on the Smart Array 3200 Controller is to protect against data loss due to drive failure. Although the Smart Array 3200 firmware is designed to protect against normal drive failure, it is imperative that the correct actions are performed to recover from a drive failure without inadvertently inducing any additional drive failures. Multiple drive failures in the same array generally result in data loss (exceptions include failures following activation of a spare drive and failure of drives in a mirrored configuration that are not mirrored to one another).

Recognizing a Drive Failure

A drive failure can be recognized in one of several ways:

- Amber LED illuminates on failed drives in a hot-pluggable tray. This, however, assumes the storage system is powered-on and the SCSI cable is working. Note that the amber LED may illuminate briefly when a hot-pluggable drive is inserted; this is normal.
- Amber LED illuminates on the front of a ProLiant Storage System if failed drives are inside (other problems such as fan failure or over-temperature conditions will also cause this LED to illuminate).
- A Power-On Self-Test (POST) message lists failed drives whenever the system is restarted (assumes that the controller detects one or more “good” drives. See Appendix H for explanation of POST messages).
- Array Diagnostic Utility(ADU) lists all failed drives. An online version of ADU is also available in Windows NT environments.
- Compaq Insight Manager can detect failed drives remotely across a network.

Fault Tolerance and Drive Failure

In the event of a drive failure, the condition of the logical drive varies depending upon the fault-tolerance method used. Since a single array of physical drives can contain multiple logical drives with different fault-tolerance methods, conditions of each logical drive on the same array are not necessarily the same. At any one time, if more drives are failed than the fault-tolerance method allows, fault tolerance is “compromised” and the condition of the logical drive can be referred to as “failed.” If a logical volume is “failed,” all requests from the operating system will be rejected with “unrecoverable” errors.

A Non-Fault-Tolerant (RAID 0) Logical Drive

- Can sustain no drive failures. If any physical drive in the array is failed, the condition of all non-fault-tolerant logical drives in the same array will also be “failed.” This is because data is striped across all drives in the array.

A RAID 1 (Mirroring) Logical Drive

- Can sustain multiple drive failures as long as failed drives are not mirrored to one another.
- Will be in a “failed” condition if any two failed drives are mirrored to one another.
- Will be in a “regenerating” condition if at least one drive is failed and no failed drives are mirrored to one another.
- Will be in a “rebuilding” condition if a previously failed drive has been replaced and the replacement drive is rebuilding. The volume may also be in a “rebuilding” condition following a drive failure if a spare drive was previously assigned and is rebuilding.

In any RAID 1 logical drive on the Smart Array 3200 having N physical drives in the array (not including spare drives), the first N/2 physical drives are normally mirrored in consecutive order to the second N/2 physical drives. When determining the order, number each drive in the array by increasing IDs on the first SCSI bus, followed by drives on the second SCSI bus.

Spare Drives

In the event of a drive failure, if a spare drive is assigned and available, the spare drive acts as an immediate replacement for the failed drive. Data is reconstructed automatically from the remaining drive(s) in the volume and written to the spare drive via the Automatic Data Recovery process. Once the spare drive is completely built, the logical drive again runs at full fault tolerance and is then able to sustain another subsequent drive failure. Note, however, that if another drive fails before the spare drive is completely built, the spare drive cannot prevent failure of the entire logical drive. Also note that it is possible for non-correctable disk errors to prevent completion of the Automatic Data Recovery process (discussed below).

Replacing a Failed Drive

Failed drives in hot-pluggable trays can be removed and replaced while host system and storage system power are both ON. Hot-pluggable drives can also be replaced when the power is OFF. Remember, however, to NEVER TURN OFF an external storage system while the host system power is on. This results in the failure of all drives in the storage system, which would likely compromise your fault tolerance. When a hot-pluggable drive is inserted, all disk activity on the controller is temporarily paused while the drive is spinning up (usually 20 seconds or so). If the drive is inserted while power is ON, in fault-tolerant configurations, recovery of data on the replacement drive begins automatically (indicated by blinking online LED).

Non-hot-pluggable drives should only be replaced while the system power is OFF. On all non-hot-pluggable drives, be sure to check the SCSI ID jumpers to make sure that the correct drive is being replaced. *To prevent compromising the fault tolerance, it is imperative that the correct physical drive be replaced.* Also, be sure that the SCSI ID jumpers are set to the same SCSI ID on the replacement drive. The SCSI ID jumpers may be located at different places on different drive models, but it is necessary that the SCSI ID on the replacement drive *always* be set to the same value as the original failed drive to prevent SCSI ID conflicts which could compromise the fault tolerance.

The capacity of replacement drives must be at least as large as the capacity of the other drives in the array. Drives of insufficient capacity will be failed immediately by the controller without starting the Automatic Data Recovery.



CAUTION: If the Smart Array 3200 Controller has a failed drive, replace this drive with a new or known-good replacement drive. In some cases, a drive that has previously failed by the controller may appear to be operational after the system is power-cycled, or after removal and reinsertion of a hot-pluggable drive. However, this practice is highly discouraged as the use of such “marginal” drives may eventually result in data loss.

Automatic Data Recovery

If a drive in a fault-tolerant configuration is replaced while the system power is OFF, the controller displays a Power-On Self-Test (POST) message during the subsequent system startup. This indicates that the replacement drive has been detected and that Automatic Data Recovery may need to be started. Press **F1** to initiate the background Automatic Data Recovery process. If Automatic Data Recovery is not enabled, the logical drive remains in a “ready-to-recover” condition and the same query displays at the next system restart.

Replacement drives are not considered to be “online” until Automatic Data Recovery is completed, at which time the online LED stops blinking and is on “solid.” Any drives that are not yet “online” are treated as if they are “failed” when trying to determine whether fault tolerance will be compromised. For example, in a RAID 5 logical drive with no spare and one drive rebuilding, another drive failure at this time would result in a “failure” condition for the entire logical drive.

In general, the time required for a rebuild is approximately 15 minutes per gigabyte. The actual rebuild time, however, depends upon the rebuild priority set for the amount of I/O activity occurring during the rebuild operation, the disk drive speed, and the number of drives in the array (RAID 4 and RAID 5). In RAID 4 and RAID 5 configurations, the rebuild time varies from 10 minutes/GB for three drives to 20 minutes/GB for 14 drives (using 9-GB wide-ultra hard drives).

Automatic Data Recovery Failure

During Automatic Data Recovery, if the online LED of the replacement drive stops blinking and all other drives in the array are still online, the Automatic Data Recovery process may have abnormally terminated due to a non-correctable read error from another physical drive during the recovery process. The background Auto-Reliability Monitoring process helps prevent this problem, but it cannot do anything about certain issues, such as SCSI bus signal integrity problems. Reboot the system and a POST message should confirm the diagnosis. Retrying Automatic Data Recovery may help. If not, a backup of all data on the system, surface analysis (using User Diagnostics), and restore is recommended.

During Automatic Data Recovery, if the online LED of the replacement drive stops blinking and the replacement drive is failed (amber failure LED illuminated or other LEDs go out), the replacement drive is producing unrecoverable disk errors. In this case, the replacement drive should be removed and replaced.

Compromised Fault Tolerance

If fault tolerance is compromised due to failure of multiple drives, the condition of the logical drive will be “failed,” and “unrecoverable” errors will be returned to the host. Data loss is probable. Inserting replacement drives at this time will not improve the condition of the logical drive. If this occurs, first try turning the entire system off and on. In some cases, an intermittent drive will appear to work again (perhaps long enough to make copies of important files) after cycling power. If a 1779 POST message is displayed, press **F2** to reenable the logical drive(s). Remember that data loss has likely occurred and any data on the logical drive is suspect.

Fault tolerance may be compromised due to non-drive problems such as a faulty cable, faulty storage system power supply, or a user accidentally turning off an external storage system while the host system power was on. In such cases, the physical drives do not need to be replaced. However, data loss can occur, especially if the system was busy at the time the problem happened.

G-6 *Recovering from Drive Failure*

In cases of “legitimate” drive failure, once copies of important data have been made (if possible), replace any drives that have failed to prevent further drive problems in the future. After these (multiple) drives are replaced, the fault tolerance may again be compromised, power may need to be cycled, and the 1779 POST message may again be displayed. Press **F2** to reenable the logical drive(s), recreate your partitions, and restore all data from backup.

Because of the risk that fault tolerance may be compromised at some point in the future, make regular backups of all logical drives.



Appendix H

POST Error Messages

The Smart Array 3200 Controller produces diagnostic error messages at reboot. Many of these Power-On Self-Test (POST) messages are self-explanatory and suggest corrective actions for troubleshooting. Detailed information and corrective actions are listed below.

NOTE: SCSI port 1 refers to internal or external drives attached to the internal port 1 connector. SCSI port 2 refers to external drives installed in a Compaq ProLiant Storage System attached to the external port 2 connector.

Table H-1
POST Error Messages

Code	Meaning	Recommended Action
1702	SCSI Cable Error Detected. System Halted.	This message indicates a termination or cabling problem with the system board integrated SCSI controller. Refer to cabling information in the <i>Smart Array 3200 Installation Guide</i> .
1720	Slot x Drive Array - S.M.A.R.T. Hard Drive Detects Imminent Failure SCSI: Port y: SCSI ID x.	The indicated drive has reported a S.M.A.R.T. predictive-failure condition. It may fail at some time in the future. If this drive is part of a non-fault-tolerant configuration, back up all data before replacing the drive and restore all data afterwards. If this drive is part of a fault-tolerant configuration, do not replace this drive unless all other drives in the array are on-line. Select F1 key to resume.

continued

H-2 POST Error Messages

POST Error Messages *continued*

Code	Meaning	Recommended Action
1724	Slot x Drive Array - Physical Drive Position Changes(s) Detected - Logical drive configuration has automatically been updated.	This message indicates that logical drive configuration has been updated automatically following physical drive position changes. Select F1 key to resume.
	Slot x Drive Array - Array Accelerator Memory Size Change Detected.	This message indicates that the array accelerator configuration has been updated automatically due to replacement of the Array Accelerator (or controller) with one having different memory size. Select F1 key to resume.
	Slot x Drive Array - New Logical Drive(s) Attachment Detected. If more than 32 logical drives, this message will be followed by: Auto-configuration failed: Too many logical drives.	This message indicates that the controller has detected an additional array of drives that was attached when the power was off. The logical drive configuration information has been updated to add the new logical drives. The maximum number of logical drives supported is 32-additional logical drives will not be added to the configuration. Select F1 key to resume.
	Slot x Drive Array - Capacity Expansion Process is Temporarily Disabled (followed by one of the following): 1. Expansion will resume when Array Accelerator has been reattached. 2. Expansion will resume when Array Accelerator has been replaced. 3. Expansion will resume when Array Accelerator RAM allocation is successful. 4. Expansion will resume when Array Accelerator battery reaches full charge. 5. Expansion will resume when Automatic Data Recovery has been Completed. (RESUME = F1 KEY)	The capacity expansion process has been temporarily disabled for the reason indicated, and will automatically resume. If the array accelerator has been removed, you must reinstall it for capacity expansion to continue.

continued

POST Error Messages *continued*

Code	Meaning	Recommended Action
	Slot x Drive Array Option ROM Appears to Conflict with an ISA Card - ISA cards with 16-bit memory cannot be configured in memory range C0000 to DFFFF along with SMART-2/E 8-bit Option ROM due to EISA bus limitations. Please remove or reconfigure your ISA card. (RESUME = F1 KEY)	Remove or reconfigure the conflicting ISA card, referring to the directions provided with the ISA card. Alternatively, the Option ROM can be disabled on the SMART-2/E controller via the System Configuration Utility if a SMART-2/E is not the primary (boot) controller.
	Slot x Drive Array requires System ROM Upgrade. Run System ROMPaq Utility (RESUME = F1 KEY)	Run the latest version of System ROMPaq. See Chapter 3 for details.
	Slot x Drive Array Option ROM is Not Programmed Correctly or may Conflict with the Memory Address Range of an ISA Card. Check the Memory Address Configuration of installed ISA Card(s) or Run Option ROMPaq Utility to attempt SMART-2/E Option ROM Reprogramming. (RESUME = F1 KEY)	Check the Memory Address Range of any ISA cards that may be installed, and verify that they do not conflict with the address of the SMART-2/E Option ROM as shown via the System Configuration Utility. If there is no conflict, run Option ROMPaq and attempt to reprogram the SMART-2/E Option ROM as described in the section, "Running Option ROMPaq," in Chapter 3.
	Slot x Drive Array - Resuming logical drive expansion process.	No action required. This message appears whenever a controller reset or power cycle occurs while array expansion is in progress.

continued

H-4 POST Error Messages

POST Error Messages *continued*

Code	Meaning	Recommended Action
	<p>Slot x Drive Array - Drive(s) disabled due to failure during expansion (possibly followed by one of the following additional details:)</p> <ol style="list-style-type: none">1. Array Accelerator Removed or Failed; Expansion Progress Data Lost.2. Expansion Progress Data Could Not Be Read From Array Accelerator.3. Expansion Aborted due to Unrecoverable Drive Errors.4. Expansion Aborted due to Array Accelerator Errors. <p>Select F1 to continue with logical drives disabled</p> <p>Select F2 to accept data loss and to re-enable logical drives</p> <p>(RESUME = F1 OR F2 KEY)</p>	<p>Data has been lost while expanding the array, therefore the drives have been temporarily disabled. Press F2 to acknowledge the data loss and reenable the logical drives. Restore data from backup. If the Array Accelerator has failed, replace the Array Accelerator board after the capacity expansion progress has terminated. NEVER turn off the system and replace the Array Accelerator board if capacity expansion is in progress.</p>
1774	<p>Slot x Drive Array - Obsolete data found in Array Accelerator. Data found in accelerator was older than data found on drives. Obsolete data has been discarded.</p> <p>(RESUME = F1 KEY)</p>	<p>Data found in Array Accelerator is older than data found on drives due to drives having been disconnected, used on another controller, and then reconnected. Press F1 to discard older data.</p>
1775	<p>Slot x Drive Array - ProLiant Storage System Not Responding SCSI Port (y): Check storage system power switch and cables. Turn the system power off while checking the ProLiant power and cable connections, then turn the system power back on to retry.</p> <p>(RESUME = F1 KEY)</p>	<p>Turn off power to system. Check external ProLiant power switch - external drives must all be powered up before or at the same time as the main system. Check cables. If retry does not help, try replacing the cable, ProLiant firmware, ProLiant backplane, or the Smart Array 3200 Controller.</p>

continued

POST Error Messages *continued*

Code	Meaning	Recommended Action
1776	Slot x Drive Array - SCSI Port (y) Termination Problem Detected. (RESUME = F1 KEY)	The termination power signal for the specified SCSI port was shorted to ground. Termination power was automatically turned off to prevent damage to the internal hardware. Turn off the server power and check the cabling to the specified SCSI port. Replace damaged cables/faulty SCSI devices attached to cable.
1777	Slot x Drive Array - ProLiant Drive Storage System Problem Detected (followed by one or more of the following): SCSI Port (y): Cooling Fan Malfunction Detected SCSI Port (y): Overheated Condition Detected SCSI Port (y): Side-Panel must be Closed to Prevent Overheating SCSI Port (y): Redundant Power Supply Malfunction Detected SCSI Port (y): Wide SCSI Transfer Failed SCSI Port (y): Interrupt Signal Inoperative (RESUME = F1 KEY)	Check cooling fan operation by placing hand over fan. Check internal plenum cooling fan in tower servers or storage systems. If fan is not operating, check for obstructions and check all internal connectors. Replace unit side panel if removed. If the ProLiant Storage System power LED is amber instead of green, this indicates a redundant power supply failure. Check SCSI cables. Note that port 1 refers to the "internal" SCSI bus, and port 2 refers to the "external" SCSI bus. If the message indicates to check SCSI cables, refer fo cabling information in the <i>Smart Array 3200 Installation Guide</i> .
1778	Slot x Drive Array resuming Automatic Data Recovery process.	No action required. This message appears when a controller resets or power cycle occurs while Automatic Data Recovery is in progress.
1779	Slot x Drive Array - Replacement drive(s) detected OR previously failed drive(s) now appear to be operational: Port (y): SCSI ID (x): Restore data from backup if replacement drive x has been installed.	If this message appears and drive x (identified by its SCSI ID) has not been replaced, this indicates an intermittent drive failure. This message also appears once immediately following drive replacement before data is restored from backup.

continued

H-6 POST Error Messages

POST Error Messages *continued*

Code	Meaning	Recommended Action
1783	Slot x Drive Array Controller Failure.	If this message appears immediately following a ROM installation, the ROM is defective or not installed properly. Check to see if the Array Accelerator board is attached properly. Check that the array controller is firmly inserted in its slot. Try upgrading the System ROMs. Otherwise, replace the Smart Array controller.
1784	Slot x Drive Array Drive Failure. The following SCSI drive(s) should be replaced: SCSI Port (y) SCSI ID (x)	Check for loose cables. Replace defective drive x and/or cable(s).
1785	Slot 1 Drive Array not Configured (preceded by one of the following:) 1. Run Compaq Array Configuration Utility. 2. No drives detected. 3. Array Accelerator Memory Size Increased. 4. External Cable(s) Attached to Wrong SCSI Port Connector(s). 5. Drive positions cannot be changed during Capacity Expansion. 6. Drive positions appear to have changed. 7. Configuration information indicates drive positions beyond the capability of this controller. This may be due to drive movement from a controller that supports more drives than the current controller. 8. Configuration information indicates drives were configured on a controller with a newer firmware version.	 1. Run the Compaq Array Configuration Utility. 2. Turn off system and check SCSI cable connections to make sure drives are attached properly. 3. Run the Compaq System Configuration Utility. 4. Turn system power OFF and swap SCSI port connectors to prevent data loss. 5-6. Run Drive Array Advanced Diagnostics if previous positions are unknown. Then turn system power OFF and move drives to their original positions. 7. To avoid data loss turn system power OFF and reattach drives to the original controller. 8. To avoid data loss, reattach drives to original controller or upgrade controller firmware to the version on the original controller using Option ROMPaq. Select F1 key to resume.

continued

POST Error Messages *continued*

Code	Meaning	Recommended Action
1786	<p>Slot x Drive Array Recovery Needed. The following SCSI drive(s) need Automatic Data Recovery: SCSI Port (y): SCSI ID (x)</p> <p>Select F1 to continue with recovery of data to drive.</p> <p>Select F2 to continue without recovery of data to drive.</p> <p><i>Or</i></p> <p>Slot x Drive Array Recovery Needed. The following SCSI drive(s) need Automatic Data Recovery: SCSI Port (y): SCSI ID (x)</p> <p>Select F1 to retry Automatic Data Recovery to drive.</p> <p>Select F2 to continue without starting Automatic Data Recovery.data to drive.</p>	<p>The message normally appears when a drive was replaced in a fault-tolerant configuration with system power off. In this case, press F1 to start the automatic data recovery process.</p> <p>The "previously aborted" version of the 1786 POST message will appear if the previous rebuild attempt was aborted for any reason. Run Array Diagnostic Utility (ADU) for more information. If the replacement drive was failed, try using another replacement drive. If rebuild was aborted due to a read error from another physical drive in the array, you'll need to back up all readable data on the array, run Diagnostics Surface Analysis, and then restore your data.</p>
1787	<p>Slot x Drive Array Operating in Interim Recovery Mode. The following SCSI drive(s) should be replaced: SCSI Port (y): SCSI ID (x)</p>	<p>Following a system restart, this message reminds you that drive x is defective and fault tolerance is being used. Drive x needs replacement as soon as possible. A loose or defective cable may also cause this error.</p>

continued

H-8 POST Error Messages

POST Error Messages *continued*

Code	Meaning	Recommended Action
1788	<p>Slot x Drive Array Reports Incorrect Drive Replacement. The following SCSI drive(s) should have been replaced: SCSI Port (y): SCSI ID (x).</p> <p>The following SCSI drive(s) were incorrectly replaced: SCSI Port (y): SCSI ID (z).</p> <p>Select F1 to continue - drive array will remain disabled.</p> <p>Select F2 to reset configuration - all data will be lost.</p>	<p>The drives indicated were installed in the wrong place, so they have been disabled. Reinstall the drives correctly.</p> <p>Press F1 to restart the computer with the drive array disabled. Run ADU for more information.</p> <p><i>-Or-</i></p> <p>Press F2 to use the drives as configured and lose all the data on them.</p>
1789	<p>Slot x Drive Array Physical Drive(s) Not Responding. Check cables or replace the following drives: SCSI Port (y): SCSI ID (x)</p> <p>Select F1 to continue - drive array will remain disabled.</p> <p>Select F2 to failed drives that are not responding - Interim Recovery Mode will be enabled if configured for fault tolerance.</p>	<p>This message indicates that previously operating drives are missing or inoperative following a cold or warm reset. Turn off system and check cable connections. If cables are connected, replace the drive. Press F1 to restart the computer with the drive array disabled.</p> <p><i>-Or-</i></p> <p>If you do not want to replace the drives now, press F2.</p>
1792	<p>Slot x Valid Data Found in Array Accelerator. Data automatically written to drive array.</p>	<p>While the system was in use, power was interrupted or the system was restarted while data was in the Array Accelerator memory. Power was then restored within four days, and data in the Array Accelerator was flushed to the drive array.</p>

continued

NOTE: Message 1788 might also be displayed inadvertently due to a bad power cable connection to the drive or a defective SCSI cable. If this message was due to a bad power cable connection, repair the connection and press F2. If this message is not eliminated by pressing F2, run the Drive Array Advanced Diagnostics Utility.

-OR-

If this message was not due to a bad power cable connection, and the drive was not replaced, this could indicate a defective SCSI cable. Contact your Authorized Compaq Service Provider.

POST Error Messages *continued*

Code	Meaning	Recommended Action
1793	Slot x Drive Array - Array Accelerator Battery Depleted. Data in Array Accelerator has been lost. (Error message 1794 also displays.)	While the system was in use, power was interrupted while data was in the Array Accelerator memory. Power was not restored within four days, and data in the Array Accelerator was lost. Check all files for potential data corruption. -Or- The Array Accelerator batteries have failed.
1794	Slot x Drive Array - Array Accelerator Battery Charge Low. Array Accelerator is temporarily disabled. Array Accelerator will be reenabled when battery reaches full charge.	The battery charge is below 90%. Posted writes are disabled. When the batteries are fully charged, the Array Accelerator will automatically be reenabled and this POST message will be discontinued. Replace the Array Accelerator or the Smart Array Controller if batteries do not recharge within 36 power-on hours.
1795	Slot x Drive Array - SMART-2 Controller Configuration Error. Data does not correspond to this drive array. Array Accelerator is temporarily disabled.	The data stored in the Array Accelerator does not correspond to this drive array. Match the Array Accelerator to the correct drive array. -Or- Run the Compaq System Configuration Utility to clear data in the Array Accelerator.
1796	Slot x Drive Array - Array Accelerator is not responding. Array Accelerator is temporarily disabled.	The Array Accelerator is not responding. Replace the Array Accelerator or the Smart Array Controller.
1797	Slot x Drive Array - Array Accelerator Read Error Occurred. Data in Array Accelerator has been lost. Array Accelerator is disabled.	Replace the Array Accelerator or the Smart Array Controller. Restore data from backup.

continued

H-10 POST Error Messages

POST Error Messages *continued*

Code	Meaning	Recommended Action
1798	Slot x Drive Array - Array Accelerator Write Error Occurred. Array Accelerator is disabled.	Replace the Array Accelerator or the Smart Array Controller.
1799	Slot x Drive Array - Drive(s) Disabled due to Array Accelerator Data Loss. Select F1 to continue with logical drives disabled. Select F2 to accept data loss and to reenable logical drives.	Data stored in the Array Accelerator has been lost, therefore the drives have been temporarily disabled. Press F2 to acknowledge the data loss and reenable the logical drives. Restore data from backup.